

Maharashtra State Electricity Distribution Co. Ltd.

| Tender Details | | 21-02-2024 06:20:32 |
|---|--|---------------------|
| Tender Code | MMD/T-HTM1-01/0224 | |
| Tender Type | Procurement Tender | |
| Type Of Bid | Two Bid | |
| Description | Procurement of 11 KV/0.433 KV, 25 KVA three phase Distribution Transformers with energy efficiency Level-I as per IS: 1180/2014 under HVDS Ag Scheme | |
| Estimated Cost (In Lakhs) | 4816 | |
| Basis of prices | Firm Price Basis | |
| Tender Validity | 120 | |
| Delivery Requirement (In Months) | 9 | |
| Tender on rate contract basis | NO | |
| Tender Fee (In INR) | 25000 | |
| GST In INR (@18% on Tender Fee: SAC No. | 4500 | |
| Total Tender Fee Amount including GST in INR. | 29500 | |
| Contact | Shri Kirankumar Shinde , 7045791361 ,cemmcsedcl@gmail.com | |
| Pre-Qualifying Req | As per tender documents. | |
| Budget Type | NA | |
| Scheme Code | null | |
| Scheme Name | | |
| Department | Material Management Cell | |
| Office Type | HO | |
| Location Type | Corporate Office | |
| Designation | Executive Engineer(Distribution) | |
| Pre-Bid Meeting Address | OFFICE OF THE CHIEF ENGINEER, Maharashtra State Electricity Distribution Co. Ltd. Material Management Department, Plot No. G-9, "Prakashgad" First floor, Prof. A.K. Marg, Bandra (E), Mumbai – 400 051. E-mail- cemmcsedcl@mahadiscom.in cemmcsedcl@gmail.com | |
| Bid Opening Address | OFFICE OF THE CHIEF ENGINEER, Maharashtra State Electricity Distribution Co. Ltd. Material Management Department, Plot No. G-9, "Prakashgad" First floor, Prof. A.K. Marg, Bandra (E), Mumbai – 400 051. E-mail- cemmcsedcl@mahadiscom.in cemmcsedcl@gmail.com | |
| Version No | 1 | |
| Call for Deviation | YES | |
| Is Annexure C1 Applicable | YES | |
| Is Manufacturer Applicable | YES | |
| Is Trader Applicable | NO | |
| Minimum % of Offered Quantity | 20 | |
| Is Power Supplier Applicable | NO | |
| Tender Sale Start Date | 21-02-2024 19:00 | |
| Tender Sale End Date | 14-03-2024 12:00 | |
| Bid Start Date | 21-02-2024 19:05 | |
| Bid End Date | 14-03-2024 15:00 | |
| Pre-Bid Meeting Date | 27-02-2024 15:00 | |
| Techno-Commercial Bid opening on | 14-03-2024 15:30 | |
| Price Bid opening on | Will be declared later | |
| Annexure C1 Opening Date | Will be declared later | |
| Winner Selection Date | Will be declared later | |
| Can Bidder opt for EMD Exemption | YES | |
| Is Annexure-E [Consent for MSEDCL Standard Technical Specifications and GTP] Applicable ? | NO | |



MATERIAL MANAGEMENT DEPARTMENT
MAHARASHTRA STATE ELECTRICITY DISTRIBUTION CO. LTD.
Tender No. MMD/T-HTM1-01/0224

BID NOTICE

The Chief Engineer, Material Management Department (MMD), on behalf of Maharashtra State Electricity Distribution Company Limited (the Purchaser), hereby invites sealed bids from eligible bidders for procurement of 11 KV/0.433 KV, 25 KVA, Three Phase Distribution Transformers with Energy Efficiency Level I as per IS 1180:2014. Entire bidding document is available online on <https://etender.mahadiscom.in/eatApp/> as per date indicated below. Any changes in the Bid Schedule, corrigendum etc. shall also be notified via MSEDCL's website. Prospective bidders are therefore requested to regularly check the website for any updates.

Tender No. MMD/T-HTM1-01/0224

Estimated Tender Cost: Rs.48.16 Crores (inclusive of 18 % GST)

Tender Fee: Rs. 25,000.00 + 18% GST

The bidder should submit non-refundable Bid Fee of Rs. 25,000.00 + 18% GST paid through online payment only, prior to the dead line for submission of bids as per the procedure led by the MSEDCL.

Earnest Money Deposit:

The bid must be accompanied with EMD @ 0.50% (Half Percent) value of the estimated cost of offered quantity of the tender in the form of BG as per the Annexure-M enclosed with tender documents having validity of 120 days from opening of tender. Interest shall not be allowed on EMD.

The scanned copy of the online payment receipt / Demand Drafts / BG should be uploaded (in e-tendering) and the Demand Drafts/BGs should be submitted to this office on or before submission date and time.

| Calendar of Events Event | Date and Time |
|-------------------------------------|--|
| Begin Sale of Bid Document | 21.02.2024 |
| Date and time of submission of Bids | 14.03.2024 at 15:00 hrs. |
| Date and time of Bid Opening | 14.03.2024 at 15:30 hrs. |
| Date and time of Pre bid meeting | 27.02.2024 at 17:00 hrs. Online Pre-meeting: Google Meet joining info Video call link: https://meet.google.com/ayt-pbbd-xmc |

THE CHIEF ENGINEER
Maharashtra State Electricity Distribution Co. Ltd.
Material Management Department,
Plot No. G-9, "Prakashgad" First floor, Prof. A. K. Marg,
Bandra(E), Mumbai-400051.
E-mail- cemmcsedcl@mahadiscom.in, cemmcsedcl@gmail.com

MAHARASHTRA STATE ELECTRICITY DISTRIBUTION CO. LTD.

TENDER FOR

**Procurement of 11 kV/0.433 KV, 25 kVA three phase
Distribution Transformers with energy efficiency Level-I as
per IS: 1180/2014.**

Tender No: **MMD/T-HTM1-01/0224**



**THE CHIEF ENGINEER
Maharashtra State Electricity Distribution Co. Ltd.
Material Management Department,
Plot No. G-9, "Prakashgad" First floor, Prof. A. K. Marg,
Bandra(E), Mumbai-400051.
E-mail- cemmcsedcl@mahadiscom.in, cemmcsedcl@gmail.com**

=====

INDEX

| SR. NO. | CLAUSE NO. | DESCRIPTION | PAGE NO. |
|----------------|-------------------|--|-----------------|
| 1 | - | BID NOTICE | 1 |
| 2 | - | SECTION I: INSTRUCTION TO TENDERERS | 6 |
| 3 | I | SCOPE OF WORK | 7 |
| 4 | II | QUALIFYING REQUIREMENTS | 7 |
| 5 | III | PRICES | 7 |
| 6 | IV | TAXES | 7 |
| 7 | V | BASIS OF PRICES | 8 |
| 8 | VI | PRICE VARIATION | 8 |
| 9 | VII | DELIVERY | 8 |
| 10 | VIII | OFFERING THE MATERIAL | 9 |
| 11 | IX | CONFLICT OF INTEREST | 9 |
| 12 | X | QUOTATION | 9 |
| 13 | XI | AMBIGUITY IN QUOTATION | 9 |
| 14 | XII | FILLING IN OF ANNEXURE | 9 |
| 15 | XIII | ADDITIONS/ALTERATIONS PROHIBITED | 10 |
| 16 | XIV | BIS LICENSE AND BEE CERTIFICATE | 10 |
| 17 | XV | MANDATORY REQUIREMENT OF SUBMISSION OF OFFER | 10 |
| 18 | XVI | SUBMISSION OF DRAWING & BILL OF MATERIAL | 10 |
| 19 | XVII | NAME OF AUTHORIZE REPRESENTATIVE | 10 |
| 20 | XVIII (A) | OFFER OF MICRO and SMALL ENTERPRISES AND OTHER UNITS | 11 |
| 21 | XVIII (B) | PREFERENCE TO INDUSTRIAL UNITS LOCATED IN MAHARASHTRA AND OFFERS BY MATCHING RATES WITH LOWEST ACCEPTABLE BIDDER | 11 |
| 22 | XVIII (C) | MATCHING OF REATES | 12 |
| 23 | XVIII (D) | QUANTITY ALLOCATION | 12 |
| 24 | XIX | EARNEST MONEY DEPOSIT (EMD) | 13 |
| 25 | XX | SIGNING OF THE TENDER DOCUMENTS | 14 |
| 26 | XXI | SUBMISSION / SUPERSCRIBING OF THE TENDER DOCUMENTS | 14 |
| 27 | XXII | TIMELY SUBMISSION OF OFFER | 15 |
| 28 | XXIII | PURCHASER'S RIGHT | 15 |
| 29 | XXIV | DISREGARD OF TENDER CONDITIONS | 15 |
| 30 | XXV | PROHIBITION FOR POST TENDER CORRESPONDENCE | 15 |
| 31 | XXVI | RIGHT TO ORDER OUT QUANTITY IN VARIANCE TO OFFERED QUANTITY | 16 |
| 32 | XXVII | ACCEPTANCE OF TENDER | 16 |
| 33 | XXVIII | NOTIFICATION OF AWARD | 16 |
| 34 | XXIX | EARNEST MONEY OF UNSUCCESSFUL BIDDER | 16 |
| 35 | XXX | VALIDITY OF OFFERS | 16 |
| 36 | XXXI | DECLARATION FROM BIDDER | 16 |
| 37 | XXXII | CORRUPT OR FRAUDULENT PRACTICES | 16 |
| 38 | XXXIII | INFLUENCE | 17 |
| 39 | XXXIV | TENDER FEES EXEMPTION | 17 |
| 40 | XXXV | PRE-BID MEETING | 17 |
| 41 | XXXVI | CLARIFICATION ON DEVIATIONS | 18 |
| 42 | - | CERTIFICATE | 18 |

| SR. NO. | CLAUSE NO. | DESCRIPTION | PAGE No |
|---------|------------|--|---------|
| 43 | - | Section II: CONDITIONS OF TENDER AND SUPPLY | 19 |
| 44 | 1 | EFFECT OF CONTRACT | 19 |
| 45 | 2 | QUALITY OF SUPPLIES | 19 |
| 46 | 3 | MATERIAL AND COMPONENTS | 19 |
| 47 | 4 | ACCEPTANCE OF SUPPLIES/INSPECTION | 19 |
| 48 | 5 | RIGHT TO CARRY OUT INSPECTION DURING MANUFACTURING | 20 |
| 49 | 6 | RIGHT TO REVISE DESPATCH INSTRUCTIONS, DELIVERY SCHEDULE AND TO DEFER SUPPLIES | 20 |
| 50 | 7 | WAGAN LOADS/TRUCK LOADS | 21 |
| 51 | 8 | ROAD TRANSPORT | 21 |
| 52 | 9 | DESPATCH INTIMATION | 21 |
| 53 | 10 | BILL OF MATERIALS | 21 |
| 54 | 11 | PACKING LIST | 21 |
| 55 | 12 | REPLACEMENT OF GOODS LOST, BROKEN OR DAMAGED | 22 |
| 56 | 13 | REPLACEMENT OF REJECTED MATERIALS | 22 |
| 57 | 14 | MATERIAL DESPATCHED AND PROGRAMME | 23 |
| 58 | 15 | MATERIAL RECEIPT & SUBMISSION OF BILLS AT CONSIGNEE | 23 |
| 59 | 16 | PAYMENT OF BILLS | 24 |
| 60 | 17 | TAXES | 25 |
| 61 | 18 | DEDUCTION | 25 |
| 62 | 19 | GUARANTEE | 26 |
| 63 | 20 | (I) LIFTING OF REJECTED/DAMAGED MATERIALS FROM STORES AND (II) LIFTING OF FAILED TRANSFORMERS FROM DIVISION FILTER UNIT | 26 |
| 64 | 21 | LIQUIDATED DAMAGES FOR LATE DELIVERY | 28 |
| 65 | 22 | ORDER PLACED ON TIME PREFERENCE BASIS (WHEREVER APPLICABLE) | 28 |
| 66 | 23 | FORCE MAJEURE CLAUSE | 28 |
| 67 | 24 | ACCEPTANCE OF LOWER FORD RATE OFFERED IN SUBSEQUENT TENDER | 29 |
| 68 | 25 | PERFORMANCE OF CONTRACT | 29 |
| 69 | 26 | CONTRACT PERFORMANCE DEPOSIT | 29 |
| 70 | 27 | POWER OF ATTORNEY | 30 |
| 71 | 28 | SETTLEMENT OF DISPUTE | 30 |
| 72 | 29 | JURISDICTION | 30 |
| 73 | 30 | TERMINATION OF CONTRACT | 30 |
| 74 | 31 | DEBAR/BLACKLISTING OF MANUFACTURER | 31 |
| 75 | 32 | TAX DEDUCTED AT SOURCE | 31 |

| SR. NO. | CLAUSE NO. | DESCRIPTION | PAGE No |
|----------------|-------------------|--|----------------|
| 76 | - | Section III: SPECIAL TERMS & CONDITIONS AND INSTRUCTIONS TO THE TENDERES | 32 |
| 77 | - | ANNEXURE B- PRICE SCHEDULE | 34 |
| 78 | - | ANNEXURE C-1 : MATCHING RATE | 35 |
| 79 | - | ANNEXURE – D : TECHNICAL SPECIFICATION | 36 |
| 80 | - | ANNEXURE – O : CONSENT FOR PARTICIPATION IN TENDER AS NEW SUPPLIER | 37 |
| 81 | - | ANNEXURE – F | 38 |
| 82 | - | ANNEXURE – G :PRICE VARIATION | 39 |
| 83 | - | ANNEXURE – H :GUARANTEED TECHNICAL PARTICULAR | 40 |
| 84 | - | ANNEXURE – I: DECLARATION FORMAT. | 41 |
| 85 | - | ANNEXURE – J : DISPATCH INSTRUCTIONS | 42 |
| 86 | - | ANNEXURE – K : LIST OF STORES | 43 |
| 87 | - | ANNEXURE – M : BANK GUARANTEE FORMAT FOR EMD | 44 |
| 88 | - | ANNEXURE – N : BANK GUARANTEE FORMAT FOR CONTRACT PERFORMANCE DEPOSIT | 45 |
| 89 | - | SCHEDULE- C | 47 |
| 90 | - | INSPECTION CALL FORMAT | 48 |
| 91 | - | FORMAT FOR FORMAT-A | 49 |
| 92 | - | FORMAT FOR FORMAT-C | 50 |

SECTION-I

INVITATION TO TENDER AND INSTRUCTION TO BIDDERS

TENDER FORM (NOT TRANSFERABLE)

(TO BE SUBMITTED ONLINE DULY FILLED IN AND DIGITALLY SIGNED)

To be submitted online not later than the date mentioned in the tender details. For participating in tender opening, the bidder can login at the specified time and date of opening of the tender, if he desires so.

The bidder is requested to quote his lowest rates F.O.R. destination for the supply of materials. The material is required at various places in the State of Maharashtra. The tender documents duly filled-in and digitally signed, are to be submitted online before due time & date of the submission of tender in prescribed form.

The modifications made to the terms & conditions shall applicable to this tender only.

FOR CHIEF ENGINEER (M.M.DEPARTMENT)

INSTRUCTIONS TO THE BIDDERS**I SCOPE OF WORK:**

The scope of work under this tender is for design, engineering (wherever applicable), manufacture, inspection & testing before dispatch, packing and supply of material / equipments as specified in Annexure-D (Technical Specifications) at various destination sites / stores centers of the purchaser in Maharashtra.

The actual quantity that will be procured may vary depending upon the site requirement. The quantity advertised against various capacities can undergo change.

The list of various destination sites / stores centers of the purchaser is enclosed as Annexure K.

II Qualifying Requirements:

Qualifying requirement will be as per Section-III.

III PRICES:

(i) Prices are acceptable only on F.O.R. destination basis inclusive of Goods and Service Tax (GST for brevity) i.e. Integrated GST (IGST) for outside State / Central GST+ State GST (CGST+SGST) for within State, risk in transit, freight showing the break-up as desired in the Annexure 'B'. It shall be noted that quotations not conforming to F.O.R. destination basis inclusive of IGST/(CGST+SGST) etc. and to the unit as specified in Annexure 'B', shall be rejected even though the bidder's offer may be lowest. The bidder shall quote Ex-Works Price and element of freight and insurance along with applicable rate of IGST/(CGST+SGST). The F.O.R. destination price i.e. up to site or the Store Centre of the purchaser as the case may be inclusive of IGST/(CGST+SGST), risk in transit and freight will be programmatically calculated. While raising the invoices, however, IGST/(CGST+SGST) should be shown separately in the invoice raised.

(ii) For each of the items quoted, bidder shall specify offered quantity. However, the offered quantity shall not be less than 20% of the advertised quantity (Advertised quantity means the quantity required as indicated in Annexure 'B' / Price Bid) so as to deliver the said quantity within the delivery requirement of the Purchaser as indicated in the tender documents.

IV TAXES:

(i) The Purchaser shall be registered under Goods and Service Tax Act and should comply with all the statutory compliance requirements of GST Law diligently.

(ii) It is imperative for the bidder to indicate the amount of IGST/(CGST+SGST) included in their price while giving the break-up of F.O.R. destination price in Annexure 'B', failing which, the offer will be treated as ambiguous and will be rejected as per the provisions of clause X of tender form.

(iii) After awarding the contract, the supplier shall not charge any additional amount towards GST; during the currency of contract except statutory variation by Central / State Government in normal (full) rate of integrated GST. In case the GST is decreased than the rate indicated in the price bid, the benefits of the reduction in

the GST shall be passed on to the purchaser. The increase in the GST rate due to increase in turnover during the contractual delivery period shall not be charged to the purchaser.

- (iv) Necessary documentary evidence for the GST claimed shall be submitted along with the bills.

V BASIS OF PRICES:

The bidder shall quote the prices on firm price basis, as has been specifically brought out in the Tender Details. For any deviation in this regard, the offer shall be summarily rejected.

VI PRICE VARIATION:

Not applicable.

VII DELIVERY:

- (i) Bidder is requested to quote delivery F.O.R. DESTINATION only & only in the unit of the item specified in Annexure 'B' i.e. if the quantity is in sets or in tones or in numbers or in kilometers or in coils, the rate of delivery shall only be in the same unit.
- (ii) It is mandatory on the part of the tenderer to quote the delivery on monthly basis. If the offered delivery is indicated on quarterly basis, then the delivery would be counted proportionately in three equal installments per month for liabilities of the contract including levy of liquidated damages.
- (iii) Size mix for the purpose of delivery, when delivery is quoted in assorted items, shall be determined by the Purchaser while issuing the A/T or dispatch instructions and will be binding on the bidder. The Purchaser will also have the liberty of modifying the size mix for the purpose of delivery, even after the A/T is issued.
- (iv) Offer shall be rejected if the commencement period and rate of delivery per month is not indicated.
- (v) The scheduled delivery period is 9 months from the letter of award will be as below;
- Commencement Period (CM): Min. 10% of offered quantity within 2 months.
- Completion Period (CP): Balance offered quantity in 7 or less months in equated lots.
- (vi) MSEDCL may issue dispatch instructions as per requirement. The quantity demanded per consignee may be less than or equal to monthly lot specified in contract. Wherever as per demand, if the quantity to be supplied to a consignee in a particular month is less than monthly lot quantity; the said quantity will be treated as lot quantity for the purpose of delivery and payment.
- (vii) MSEDCL may instruct the supplier to withhold entire or part of monthly supply of material for a specified period by giving two months advance instruction.
- (viii) Time being the essence of contract, the supplier shall strictly maintain monthly delivery schedule.

=====

The bidder is advised to get their type tests & drawing approval immediately after placement of LoA so that the material is received by the purchaser well within the committed delivery period. If there is any delay in delivery of material as per schedule, the undelivered quantity as per schedule can be diverted to other good performing bidder.

VIII OFFERING THE MATERIAL:

- (A) The bidder shall offer the material as per MSEDCL technical specifications as per Annexure-D and shall have to fill the entire GTP.
- (B) The person / entity should not have controlling stake in more than one entity applied for the tender / bid. **Necessary certificate duly certified by Chartered Accountant to this effect shall be submitted along with the tender documents.**
- (C) Factory address, from which the bidder intends to supply the material against the tender, shall be as indicated in the latest approved online vendor registration form on e-tendering through which the vendor is submitting the offer.
- (D) The bidder shall offer the rates, taxes as applicable for the factory location indicated in his latest approved online vendor registration form on e-tendering through which he is submitting his offer.

IX CONFLICT OF INTEREST

A bidder may be considered to have a conflict of interest with one or more parties in a bidding process if they:

- (a) Have controlling shareholders in common; or
- (b) Receive or have received any director in direct subsidy from any of them; or
- (c) Have the same legal representative for purposes of a bid; or
- (d) Have a relationship with each other, directly or through common third parties, that puts the bidder in a position to have access to information about or influence on a bid of another bidder, or influence the decisions of the purchaser regarding the bidding process.

Bidders found to be in conflict of interest, shall be disqualified.

X QUOTATION:

- (i) Bidder shall quote his rate per unit specified in Annexure 'B' / Price Bid in figures.
- (ii) Bidder's printed terms and conditions will not be considered as forming part of the tender.

XI AMBIGUITY IN QUOTATION:

The bidder is requested to please make a note that in case of ambiguous terms in respect of offered quantity in Annexure- B and schedule 'C', F.O.R. condition, GST, basis of price (i.e. firm / variable) or if the blanks are left out in the offer, the item / tender shall be rejected.

XII FILLING IN OF ANNEXURE:

The bidder is requested to ensure that the comments against each and every item/clause of Annexure shall be clearly filled in and answered. Any item/clause shall not be left blank or unanswered. If any item /clause is not applicable, the "Not Applicable (N.A.)" check box shall be selected.

=====

XIII ADDITIONS/ALTERATIONS PROHIBITED:

The bidder shall not make any additions, alterations or changes in the Tender Form and the Conditions of Tender & Supply (Annexure 'A') including the description of material mentioned in Annexure 'B'. They should quote rate for the material described or click the check box 'Not quoted' against each of the item in Annexure 'B' / Price Bid.

XIV B.I.S. LICENCE AND BEE CERTIFICATE :

A scanned copy of valid BIS License & BEE certifications for offered items ratings duly sealed & signed must be uploaded and submitted along with offer, failing which, the offer shall be rejected.

In case the validity of the BIS license / BEE certifications is expiring before date of submission of tender, necessary documentary proof of having applied for renewal of validity of the BIS license must be uploaded while submitting the bid. The renewed copy of the BIS License / BEE certifications shall be submitted before commencement of supply.

However, valid BIS license / BEE certifications scan copy of offered material must be submitted by the qualifying bidders before commencement of supply, failing which their order will be cancelled with financial liability on supplier.

XV MANDATORY REQUIREMENT OF SUBMISSION OF OFFER:

The offer shall be submitted online duly filled in; attaching all the required documents, completed in all respects and should be digitally signed.

XVI SUBMISSION OF DRAWING & BILL OF MATERIAL:

The bidder shall submit the drawings and bill of material conforming to the tender specification wherever applicable. In such cases, the offer without the drawings and bill of material shall not be evaluated and considered. The drawings and bill of material submitted along with the bid shall not be considered for evaluation of the offer but the drawings and bill of material of the successful bidder shall be scrutinized when the Purchaser decides to accept such bid. It may, however, be noted that Purchaser's action of evaluation of the tendered bid would not mean approval of the drawings and bill of material submitted along with the tender bid.

The bidder shall depute his authorized representative for discussion on the drawings, either immediately on hearing from the Purchaser or after receipt of Letter of Award. The formalities like submission of drawings, bill of material etc. and getting the same approved by the Purchaser shall be completed by the successful bidder within TEN DAYS from the date of Letter of Award of the contract. The approval to drawings complete in all respects mentioned in technical specifications (Annexure-D) will be accorded within SEVEN working days thereafter. Any delay in this regard shall lead to cancellation of the Letter of Award at the risk and cost of the bidder. The supplies against the contract shall conform to the approved detailed drawings / bill of material and the detailed technical specifications.

XVII NAME OF AUTHORIZED REPRESENTATIVE:

The digital certificate shall be in the name of person authorized by the firm. In case, the digital certificate is compromised or the person holding the digital certificate is no longer authorized to digitally sign the tender, it is the responsibility of the bidder to revoke this certificate and obtain the fresh certificate. While submitting the bids online only valid digital

certificate shall be used. The vendors are requested to check the validity of digital signature and prior to the expiry date & they are requested to get their Digital signature key validated before expiry of the same. MSEDCL shall not be responsible for Non-submission of any of the Bids (Techno Commercial Bid, Deviation Bid, Price Bid, Annexure - C-1) by vendors due to expired/Invalid Digital signature.

The bidder is responsible for all the contractual liabilities and responsibilities thereof.

In case the bidder authorizes the representative to deal on behalf of the bidder, the name and address of such person should be informed to the purchaser. The bidder shall submit the power of Attorney in favour of representative duly executed before the Notary. In the absence of the Power of Attorney, the purchaser shall not deal with the representative.

XVIII (A) OFFER OF MICRO and SMALL ENTERPRISES AND OTHER UNITS:

The bidder registered with Directorate of Industries of Government of Maharashtra for manufacturing the items tendered/offered and those who have attached valid certificate at the time of vendor registration shall be considered for concessions applicable and procurement of reserved items as per GoM G. R. dtd. 30-10-2015 amended up to date. These benefits shall be available only to those items approved during the registration process and subsequent updates in registration up to the submission of this tender.

Based on concession of Central Government's Micro and Small Enterprises office order dtd. 23-03-2012, 241 items are being kept reserved. As per above reservation of items 100 % reserved items to be purchased from Micro and Small Enterprises out of which 20 % reserved items to be purchased from S.C./S.T. enterprises. Reservation is applicable for a limited period unless and until re-examined. If Micro and Small Enterprises participated in the tender and the tendered item is not reserved, then 20 % order with L-1 rate to be given to Micro and Small Enterprises and out of this 20 %, 4 % to be given to S.C. /S.T. enterprises.

If there are any specific Government Directives such as reservation of items for units in Maharashtra, non-eligibility of preference to SSI units etc. for particular items, price and purchase preference etc. the same would be applicable irrespective of the fact that it has not been specifically incorporated in the tender notice and/or tender documents.

(B) PREFERENCE TO INDUSTRIAL UNITS LOCATED IN MAHARASHTRA AND OFFERS BY MATCHING RATES WITH LOWEST ACCEPTABLE BIDDER

The lowest acceptable rate will be the unit rate worked out without considering IGST/(CGST+SGST) as applicable and the same rate will be considered as applicable to the respective bidder who has agreed to accept order at lowest acceptable rate.

The lowest acceptable rate is known only on the date of decision by the Competent Authority, hence the lowest acceptable rates of the tender cannot be declared in advance, however lowest acceptable rate of the tender would be equal to or more than the lowest rate received in the tender.

(C) Matching of Rates:

The confirmation for acceptance of the order at the lowest acceptable rate shall be given in the format as per Annexure -'C-1' of the tender documents by the bidder other than L-1. The same should be submitted online on or before the due time and date of submission of Annexure- 'C-1'. The confirmation shall be opened online on due time and date of opening of Annexure-'C-1'. Schedule for submission and opening of Annexure-'C-1' shall be communicated separately by e-mail and on the website. Though confirmation in Annexure-'C-1' as above is called from all the qualified bidders, the bidders, who quoted rates within the range of 5 % in comparison with the lowest acceptable rates, shall only be considered and their Annexure `C-1' will be opened on the date and time intimated subsequently in the presence of bidders who chose to be present. Provided, however, that the Annexure 'C-1' of the bidders, who have quoted above the range of 5 % in comparison with the lowest acceptable rates, shall also be considered in case the aforesaid bidders within the range of 5 % are unable to fulfill the quantity requirement. In that case also, the date of opening of Annexure- `C-1' will be intimated to the bidders

In the above confirmation, if the bidder indicates any rate, then the confirmation given by the bidder will not be considered as valid.

Above confirmation for the quantity less than as indicated in Clause X (iii) (offered quantity shall not be less than 20 %) of Instructions to the bidder shall not be acceptable.

The prices indicated in the original offer shall not be considered as valid once offer for acceptance of order by matching rates is given. In the event of withdrawal of offer by matching rates within the validity period, the entire offer against the tender shall become invalid and shall be summarily rejected and the earnest money paid by the bidder shall be forfeited.

The lowest acceptable tenderer would be considered for awarding order for quantity subject to his capacity and capability as under.

(D) Quantity Allocation:

- 1) If L-1 bidder is within Maharashtra State and if total tender quantity for quoted item is offered by L-1 then 100 % quantity will be awarded to L-1 bidder for quoted item.
- 2) If L-1 bidder is within Maharashtra State and offered quantity is less than the tender quantity for quoted item then,
 - a) Quantity allotted to L-1 bidder will be equal to quantity offered by him.
 - b) Balance quantity after allotment as (a) above, will be distributed among Maharashtra State bidders as per their price ranking (if ready to match with L-1 rate) subject to maximum 50 % of total tender quantity for quoted item to Maharashtra State bidders including L-1 bidder.
 - c) Any balance quantity after allotment as (a) & (b) above, will be distributed as per their price ranking (if ready to match with L-1 rate) irrespective of bidder is Maharashtra or out of Maharashtra state bidder including partial allotment if any to Maharashtra bidder in (b) above.

- 3) If L-1 bidder is outside Maharashtra State then,
 - a) If the L-1 bidder offered more than 50 % of tendered quantity for quoted item then maximum of 50 % of tender quantity for quoted item will be allotted to L-1 bidder.
 - b) If the L-1 bidder offered less than 50 % of tendered quantity for quoted item then quantity equal to offered quantity for quoted item will be allotted to L-1 bidder.
 - c) Balance quantity after allotment as (a) or (b) above, will be distributed among Maharashtra State bidders as per their price ranking for maximum 50 % of required quantity. (if ready to match with L-1 rate).
 - d) Any balance quantity after allotment as (a) ,(b) & (c) above, will be distributed as per their price ranking (if ready to match with L-1 rate) irrespective of bidder is Maharashtra or out of Maharashtra state bidder including partial allotment if any.
 - e) If all bidders including L-1 bidder are from outside Maharashtra state and if the offered quantity of L-1 bidder is 100 % then entire quantity will be allotted to L-1 bidder. If quantity offered by L-1 bidder is less than 100 %, then after allotting to L-1 bidder balance quantity will be allocated to remaining bidder who matched the L-1 rates as per price ranking & quantity quoted.
 - f) In spite of above the quantity allocation will be at the sole discretion of MSEDCL.
- 4) If new suppliers are allowed then maximum 20% of tender quantity will be allotted for new supplier as per their price ranking.

XIX EARNEST MONEY DEPOSIT (EMD):

The bidder should pay the Earnest Money @ 0.5% (Half Percent) value of the estimated cost of offered item of the tender in the form of Demand Draft or Bank Guarantee as per the Annexure–M enclosed with tender documents having validity of 120 days from opening of tender. Interest shall not be allowed on EMD. EMD shall be forfeited (i) in case the bidder withdraws the tender / offer during the validity period (ii) in case the bidder fails to pay the performance deposit if the contract is awarded.

However, bidders from the following categories are exempted from payment of earnest money deposit.

- 1) All Government and semi Government institutions under Govt. of Maharashtra and Zilla Parishad in Maharashtra and fully owned undertaking of any State Govt. and Govt. of India only for the items manufactured by such institutions.
- 2) Micro and Small Enterprises registered under Micro, Small and Medium Enterprises Development Act-2006 only for the items mentioned in their permanent registration certificate at the time of vendor registration.
- 3) The bidder registered with N.S.I.C. and those who have attached valid N.S.I.C. Registration Certificate for the items mentioned in their permanent registration certificate at the time of vendor registration.

=====

The benefits mentioned in (1) to (3) above shall be available only to those items approved during the registration process and subsequent updates in registration up to the date of submission of this tender.

Exempted bidders should upload a latest valid certificate issued by any approved body of 'Ministry of Small & Medium Enterprises' (MSME) such as 'National Small Industries Corporation' (NSIC) or 'Udyam registration' for EMD exemption.

XX SIGNING OF THE TENDER DOCUMENTS:

Offer shall be submitted along with the tender documents and duly filled in with all Sections / Annexures / Appendixes / Schedules etc. The offer shall be signed with valid digital signature.

XXI SUBMISSION / SUPERSCRIBING OF THE TENDER DOCUMENTS:

The offer is to be submitted as follows.

(a) Online Submission:

- (i) Techno-Commercial Bid (Part-I): This part shall contain all technical and commercial aspects of the bid and documents supporting the same except the Price Bid.

The bidder is requested to please make a note that in case of the Price Bid (Part-II) is submitted instead of Techno-Commercial Bid in Part-I or submitted Price Bid (Part-II) along with Techno-Commercial Bid in Part-I, the offer shall be rejected.

- (ii) Price Bid (Part-II)

This part shall contain only the Price Bid strictly in the prescribed format, i.e. Annexure 'B'.

(b) Off line Submission:

Physical submission of documents (Part-III) – Not mandatory.

Envelope for this part shall contain documents like Type Test Reports, Drawings, Bill of Material, Catalogues etc. wherever applicable as per technical specification and they shall be scanned and these scanned documents to be taken into PDF format on CD media (2 sets) and are to be submitted to Executive Engineer (HTM-1) in the office of Chief Engineer, Material Management Department in sealed envelope on or before due date & time of submission.

METHOD OF SUBMISSION OF PART-III AND THEIR OPENING:

This envelope shall be individually sealed and shall be superscribed with the name and address of bidders and the following information before posting or delivering the same:

- i. Tender No.
- ii. Due date and time of submission.
- iii. Due date and time of opening.

Envelope as above shall be submitted on or before the prescribed due date and time of submission and shall be opened on due date and time of opening as prescribed.

In case of bidders whose techno-commercial bid is acceptable, their Price Bids will be opened at a later date. This date shall be intimated to such bidders separately.

XXII TIMELY SUBMISSION OF OFFER:

- (a) The bid is to be submitted online on or before due date and time of submission to the Purchaser at website.
- (b) It is advisable to submit the digitally signed offer sufficiently in advance of due date and time so as to avoid last minute congestion of network / server.
- (c) Offer received after the due date and time of submission shall not be accepted.
- (d) In case, the due date of opening of tender happens to be holiday, the offer shall be opened on the next working day at the same time.

XXIII PURCHASERS RIGHT:

The Purchaser reserves the right to reject any offer without assigning any reason whatsoever.

The Purchaser reserves the right to make any changes in terms & condition at any stage of the process without assigning any reason whatsoever.

If any type of legal litigation against MSEDCL is pending in any court/Forum against/by the bidder or its sister concern/Director/Partner/Proprietor, then purchaser reserves the right to reject partly or fully their bid without assigning any reasons thereof.

Bidder has to submit the declaration as per Annexure-F regarding no any type of legal litigation against MSEDCL is pending in any court/Forum against/by the bidder or its sister concern/Director/Partner/Proprietor.

XXIV DISREGARD OF TENDER CONDITIONS:

Tender containing any deviations / additions / alterations / changes in the conditions of the tender and supply as stated in Annexure 'A', 'B', 'C-I', 'D', 'O' and schedule 'C' shall not be acceptable.

The bidder having digitally signed all the tender documents indicates any deviations / additions / alterations / changes in the covering letter, unrelated annexure and schedules of the offer or elsewhere, the same shall be ignored and the offer shall be treated as meeting with all specified tender conditions.

XXV PROHIBITION FOR POST TENDER CORRESPONDENCE:

The Bidder should note that no correspondence shall be entertained or considered after the due date and time of submission of tender unless otherwise sought by the Purchaser.

The Bidder should also note that no correspondence shall be entertained or considered after the placement of LoA/AT unless otherwise sought by the Purchaser.

=====
XXVI RIGHT TO ORDER OUT QUANTITY IN VARIANCE TO OFFERED QUANTITY:

The Purchaser reserves the right to order out / procure any quantity in excess of the offered quantity with change in delivery period with mutual consent. The quantity specified may be for dispatch to one destination or several places.

XXVII ACCEPTANCE OF TENDER:

The Purchaser does not bind itself to accept the lowest or any tender; neither will any reasons be assigned for the rejection of any tender or part of tender. It is also not binding on the Purchaser to disclose any analysis report on tender/samples. The bidder on his part binds himself to supply any item or items selected from his offer in part or whole at the option of the Purchaser.

XXVIII NOTIFICATION OF AWARD:

Notification of Award of contract will be made by a letter of Award, to be sent by registered post or given by hand or by E-mail to the successful bidder by the Purchaser. It could also be made by e-mail to be confirmed in writing by registered post to the successful bidder by the Purchaser.

XXIX EARNEST MONEY OF UNSUCCESSFUL BIDDER:

Earnest money deposit will be returned to the unsuccessful bidder by RTGS within 7 (seven) working days after the tender has been decided and on submission of receipt of E.M.D. payment to the G.M. (F&A-SB), MSEDCL, Prakashgad, Prof. A.K. Marg, Bandra (East), Mumbai-400051. Earnest money deposit in the form of BG will be returned to the unsuccessful bidder within 7 (seven) working days by Chief Engineer, Material Management Department after the tender has been decided.

XXX VALIDITY OF OFFERS:

The bidder shall keep the offer valid for acceptance up to and including last date of calendar month, covering the date of completion of 120 days (one hundred and Twenty days) from the date of opening of the tender and shall also agree to extend the period of validity required by the Purchaser. The bidder shall not be allowed to modify or change the conditions of the tender while extending the period of validity.

XXXI DECLARATION FROM BIDDER:

In order to ensure participation of reliable and honest bidders / contractors / vendors, etc. the bidder shall submit the declaration along with the bid in Annexure-I.

XXXII CORRUPT OR FRAUDULENT PRACTICES:

The Maharashtra State Electricity Distribution Company Ltd. and the State require that bidders / suppliers / contractors observe the highest standard of ethics during the procurement and execution of such contracts. In pursuance of this policy, MSEDCL:

(a) defines for the purposes of this provision, the terms set forth below as follows:

- (i) "corrupt practice" means behavior on the part of officials in the public or private sectors by which they improperly and unlawfully enrich themselves and / or those close to them, or induce others to do so, by misusing the position in which they are placed, and it includes the offering, giving, receiving or soliciting of anything of value to influence the action of any such official in the procurement process or in contract execution; and

- =====
- (ii) "fraudulent practice" means a misrepresentation of facts in order to influence a procurement process or the execution of a contract to the detriment of the Employer, and includes collusive practice among bidders (prior to or after bid submission) designed to establish bid prices at artificial non-competitive levels and to deprive the Employer of the benefits of free and open competition.
- (b) will reject a proposal for award if it determines that the bidder recommended for award has engaged in corrupt or fraudulent practices in competing for the contract in question;
- (c) will declare a firm ineligible, either indefinitely or for a stated period of time, to be awarded an MSEDCL contract if at any time it determines that the firm has engaged in corrupt or fraudulent practices in competing for, or in executing, an MSEDCL contract.

XXXIII INFLUENCE:

Any efforts by the bidders to influence the owner during evaluation process before order placement will be rejected. Similarly deviation in the term of payments, penalty, performance deposit, delivery period will be treated as non-responsive quotation/offer and will not be considered for evaluation/order placement.

Bidder shall submit the undertaking certifying that they have not approached any one for undue influence.

XXXIV TENDER FEES EXEMPTION:

Tender fee to be paid at the time of uploading / online submission of the tender. Bidders from the following categories are exempted from payment of Tender fees:

- 1) All Government and semi Government institutions under Govt. of Maharashtra and Zilla Parishad in Maharashtra and fully owned undertaking of any State Govt. and Govt. of India only for the items manufactured by such institutions.
- 2) Micro and Small Enterprises registered under Micro, Small and Medium Enterprises Development Act-2006 only for the items mentioned in their permanent registration certificate at the time of vendor registration.
- 3) The bidder registered with N.S.I.C. and those who have attached valid N.S.I.C. Registration Certificate at the time of vendor registration.

The benefits mentioned in (1) to (3) above shall be available only to those items approved during the registration process and subsequent updates in registration up to the date of submission of this tender.

The tender fee paid against the particular tender shall not be refunded / transferred /adjusted at all.

XXXV PRE-BID MEETING:

- 1) The bidder or its official representative is invited to attend pre-bid meeting (s) which will take place at the place, date and time designated in the Bidding Data.
- 2) The purpose of the pre-bid meeting(s) will be to present the salient features of the bidding documents to the bidders, including the bid submittal requirements, the Conditions of Contract (including payment terms and conditions), the technical features of the project, and to clarify issues and to answer questions on any matter that may be raised by the bidders.

- 3) The bidder is advised to visit the Site and study the bid document thoroughly, and is requested to submit any questions in writing or by E-mail, to reach the Employer not later than one week before the pre-bid meeting.
- 4) Minutes of the meetings, including the text of the questions raised and the responses given will be transmitted without delay to all the prospective bidders through the website <https://etender.mahadiscom.in/eatApp/>. Any modification of the bidding documents listed which may become necessary as a result of the pre-bid meetings shall be made by the Purchaser exclusively through the issue of an Addendum pursuant to Clause and not through the minutes of the pre-bid meetings.
- 5) Non-attendance at the pre-bid meeting will not be a cause for disqualification of a bidder. Nevertheless, senior representatives of the bidders are strongly encouraged to participate in the pre-bid meeting to help ensure that they fully understand the key concerns of the Employer and the Employer's requirements.

XXXVI CLARIFICATION ON DEVIATIONS:

The purchaser, if necessary, shall obtain clarifications on deviations within 1 or 2 working days by requesting for such information from any or all the bidders in writing, as may be necessary.

The same should be submitted online on or before the due time and date of submission of Deviation Bid. The clarification shall be opened online on due time and date of opening of Deviation Bid.

The Schedule for submission and opening of Deviation Bid shall be communicated by auto generated e-mail of the e-tender website.

CERTIFICATE:

I / We agree to supply the materials at the rates herein tendered by me / us subject to the conditions of tender and supply in Annexure 'A' of this tender which I / We have carefully read and which I / we have thoroughly understood and to which I / we agree. I / we hereby agree to keep this offer open up to the date mentioned in tender details and shall be bound by communication of acceptance dispatched within the validity period.

Seal & Signature of bidder

=====

(SECTION-II)

Annexure 'A'

CONDITIONS OF SUPPLY

1) EFFECT OF CONTRACT:

The contract shall be considered as having come in to force and shall be in operation for a period of 9 months from the date of Notification of Award. The bidder whose offer is accepted is hereinafter called "the supplier".

2) QUALITY OF SUPPLIES:

All materials supplied shall be strictly as per specification laid down by MSEDCL and in accordance with the approved standard Guaranteed Technical Particulars (GTP), drawings and type test reports.

3) MATERIAL AND COMPONENTS:

The material and components not specifically stated in this specification but which are necessary for satisfactory operation of the equipment / items specified, shall be deemed to be included unless specifically excluded and shall be supplied without any extra cost.

4) ACCEPTANCE OF SUPPLIES / INSPECTION:

- i) The supplier shall normally offer at a time, the entire quantity required to be delivered every month as per the delivery schedule indicated at Annexure 'B' of A/T for the purpose of inspection by the Purchaser.

Time being the essence of contract; the supplier shall strictly maintain the monthly delivery schedule.

- ii) Materials shall be inspected by the Purchaser's Executive Engineer / or the representative authorized by the Purchaser before dispatch. An intimation in the prescribed Proforma about the date on which materials shall be ready for inspection, indicating quantity, shall have to be given to the Executive Engineer / or the representative authorized by the Purchaser before dispatch so as to reach him 10 working days in advance, failing which, the supplier shall be responsible for delay in delivery on account of inspection.

The intimation in the prescribed proforma (Inspection call) shall be forwarded on MSEDCL Material Inspection Portal i.e. <https://mip.mahadiscom.in/InspectionPortal/>. Inspection calls sent via any other media will not be entertained and the supplier will be responsible for delay in delivery on account of inspection.

On receipt of such intimation, the materials shall be inspected within 10 working days. The materials shall be dispatched only after inspection and approval of same by the Inspector. The inspection approval letter shall be valid for a period of 30 days from the date of issue of letter to enable the supplier pack the material and arrange transportation thereof so that material should be reached at the respective consignee within scheduled delivery period.

After this period of 30 days, the validity of this inspection approval letter will lapse. If the material is not reached within scheduled delivery period to respective consignees, the approval of purchaser is to be sought by the supplier for revalidation of inspection approval letter at the sole discretion of MSEDCL.

For quantity supplied beyond contractual delivery period, statutory variation is applicable only when the delayed delivery is attributed to MSEDCL.

- iii) The supplier shall notify the names of the consignees as per DI, to whom the inspected lot would be dispatched. The supplier shall get the copies of inspection approval letter together with witness certificate duly signed by the concerned Inspecting Officer and also mention reference or inspection approval letter on the challan / invoice, failing which any delay occurred in getting the S.R. Notes from the consignees would be solely to supplier's account. The inspection report shall be filled in online on the same day by the Inspector from the site on MSEDCL web portal after the inspection.
- iv) Factory address, from which the bidder has to supply the material, shall be as indicated in the latest approved on line vendor registration form on e-tendering through which the bidder has submitted the offer.
- v) The supplier shall offer inspection call intimation of readiness of material as per the monthly schedule only. In the event, during the inspection by the Purchaser's Inspecting Officer, if it is observed that the quantity actually offered for inspection is less than the quantity indicated for inspection in the inspection call, the Purchaser shall be entitled to recover from the supplier, the actual expenses incurred for arranging the inspection, and the supplier shall not dispute the amount to be recovered.
- vi) The supplier shall submit the test certificates / reports from any NABL approved laboratory or the laboratory of his own for the respective quantity of material, before dispatch. The material shall not be dispatched unless and until the test certificates are approved by the Purchaser.
- vii) All the necessary help shall be extended by the supplier to the authorized representative of the Purchaser to carry out testing of equipment / materials. Testing equipment's shall be arranged by the supplier.
- viii) MSEDCL may issue the dispatch instructions (DI) to deliver the ordered quantity to the bidders in Maharashtra within same districts of factory location of the supplier. However, it will not be binding on the MSEDCL; supplier has to deliver the material in other districts as per MSEDCL requirement. Further outside Maharashtra bidders have to deliver the material as per MSEDCL requirement to the designated consignee.
- ix) MSEDCL on its sole discretion may get material / equipment inspected and tested by third party NABL lab.

5) RIGHT TO CARRY OUT INSPECTION DURING MANUFACTURING:

The Purchaser at its option, will inspect the material ordered during its process of manufacturing including the inspection of raw materials and will request the supplier to carry out such tests as may be necessary to ensure proper quality of the material. The samples of components of the material shall be subject to quality check by the inspecting officer during manufacturing.

6) RIGHT TO REVISE DESPATCH INSTRUCTIONS, DELIVERY SCHEDULE AND TO DEFER SUPPLIES:

- i) The Purchaser reserves its right to revise the dispatch instructions issued along with the order, at the time of giving final clearance for dispatch after inspection of the material. If such change in destination is not intimated at the time of inspection approval or waiver of

inspection, the supplier shall dispatch the material as per the dispatch instruction in accordance with A/T. indicated by him in the inspection call letter.

- ii) The Purchaser reserves its right to change the delivery schedule of the contract either by reducing the monthly lot up to 60% of the agreed lot or by increasing the same up to 120% of the agreed lot with prior two months' notice and the Purchaser shall not be liable to pay any compensation/damages on account of such change in delivery schedule.
- iii) The Purchaser reserves its right to defer the balance supply to be received against the order by giving two months' notice for a maximum period of 6 months. In such an event, the delivery period for the deferred material shall be deemed to be extended proportionate to the period of deferment and the Purchaser shall not be liable to pay any compensation/damages on account of such deferment of deliveries.

7) WAGON LOADS / TRUCK LOADS:

Quantity to be dispatched to consignee should be minimum in two full truck loads and may be part load as per the Purchaser's requirements may not necessarily be in full wagon load / truck load and may be part load as per the Purchaser's requirement.

8) ROAD TRANSPORT:

In case the supplier prefers to dispatch the materials by road transport at his risk and cost and without any extra cost to the Purchaser, the materials shall be accepted only during office hours on working days. The supplier should ensure that the goods reach the stores in first half so as to arrange their unloading during office hours, failing which, the Purchaser shall not be liable for delay in unloading and for inconvenience caused to the transport contractor in the form of detention etc. Unloading at stores will be arranged by the consignee.

9) DESPATCH INTIMATION:

The supplier shall inform by e-mail to the consignee details of dispatch along with e-way bill receipt in hard & soft format giving RR / LR No., Wagon / Truck No., Type of wagon, craneable consignment or otherwise, total value of consignment, etc. to facilitate the consignee to arrange for clearance of goods on cemmcmsedcl@mahadiscom.in or cemmcmsedcl@gmail.com.

10) BILL OF MATERIALS: (WHEREVER APPLICABLE)

The supplier shall furnish bill of materials for each type of equipment / material offered which should be consistent with the drawing, specification and guaranteed technical particulars. The copies of the bill of materials should always be enclosed along with the bill submitted by the supplier for payment wherein he should specifically mention the materials / components dispatched out of the bill of materials, if the equipment is not sent in totality. Where the equipment / material to be supplied consist of more than one component, the supplier claiming payment for equipment / materials shall certify that all components of the equipment / material have been supplied in full for the quantity indicated in the invoice. Part payment shall not be allowed.

11) PACKING LIST:

Each package shall contain, in waterproof cover, the detailed list indicating the order reference, date, list of content and reference to the approved bill of materials. Each item contained in the package shall be described sufficiently to enable identification of the quantity, weight etc. There should not be any alteration in the packing list incorporated in

the order, soft copy of the packing list should be sent to all the consignees and hard copy to G.M. (F&A-SB) should be enclosed with the bills along with other documents.

12) REPLACEMENT OF GOODS LOST, BROKEN OR DAMAGED:

Notwithstanding anything herein contained, the supplier undertakes to be responsible for the safe arrival of the materials in good condition and without any loss or damage at the final destination and until the same be actually delivered to and received by the Purchaser at its stores or other place of final destination and for this purpose, materials carried by railways or other carrier shall be deemed to be so carried at the risk of the supplier. In case of transit damage / shortages, the payment shall be made only for the quantity received in good and working condition and the consignee shall lodge claims with carriers and transfer the same to the supplier with all necessary documents for settlement of the same with carriers at the supplier's end. The transit damages / shortages / losses reported by the consignee shall be repaired / replaced by the supplier duly inspected, free of cost, within one month from the date of such intimation of breakages / shortages / losses without waiting for settlement of the claims from carrier or insurance co. etc.

However, rectification of minor defects at store locations are allowed for following minor defects only.

- i. Leakages.
- ii. Bushing replacement
- iii. LA replacement
- iv. Nut bolt tightening etc.

13) REPLACEMENT OF REJECTED MATERIALS:

If, on inspection at the final destination, the Purchaser discovers any loss in the materials supplied or that they are received in damaged condition or that in the opinion of the Purchaser, they are not of the contracted quality or specification, the Purchaser shall be entitled (notwithstanding that the property in the materials shall have passed on to the Purchaser) to refuse to accept or reject the materials altogether and claim damages or cancel the contract and buy its requirements from any of its suppliers stipulating earliest possible delivery and in accordance with its tender system against the supplier and recover the damages if any, from the supplier from any outstanding sums that may be due to the supplier from the Purchaser against this contract or against any of the contract entered into with the supplier, without prejudice to other rights and remedies available to it in law and reserving always to itself the right to forfeit the performance deposit placed by the supplier for the due fulfillment of the contract.

In case the stores / materials are found not in accordance with the prescribed specifications and / or the approved sample, the same will be rejected and the supplier shall replace the rejected stores / materials free of cost within one month from the date of intimation. The replacement of goods shall also have to be got inspected as per inspection clause. Further if the stores / equipment supplied becomes incomplete on account of either rejection or short supply of its components, the complete cost of the stores / equipment shall be recovered from supplier's bills without notice.

14) MATERIAL DESPATCHED AND PROGRAMME:

A statement as under indicating dispatches effected during every month shall be furnished to this office along with the programme of manufacturing / dispatches during the following two months. In the event of no dispatch, the statement shall contain nil information.

MONTHLY STATEMENT:

- I. Name of Supplier:
- II. Reporting Month:

| Sr. No. | A/T No. | Material | Item No. as Per A/T | Consignee | RR / LR Delivery Challan No. With date | Date of Actual Receipt of Material | Qty. Dispatched Between 26 th of Preceding Month and 25 th of the Reporting month | Programme of supply during the next 2 months |
|---------|---------|----------|---------------------|-----------|--|------------------------------------|---|--|
| 1 | 2 | 3 | 4 | 5 | 6 | 7 | 8 | 9 |

Consolidated details of the above information shall be furnished to office of the Chief Engineer (M.M. Dept.) after completing the supplies of a particular order. The copy of this consolidated information shall invariably be forwarded to the respective consignees, failing which; security deposit paid against the contract shall not be released.

15) MATERIAL RECEIPT & SUBMISSION OF BILLS AT CONSIGNEE:

On receipt of material at destination of consignee as per DI, Additional Executive Engineer (MM DEPT.) of respective store should ensure the receipt of material in good & healthy condition. While receiving the material, store in charge should ensure the receipt of material as per Dispatch Instructions issued by MM Dept. Further, the store in charge should ensure the receipt of original & scan copies of following documents:

- a) Tax invoice.
- b) Detailed packing list.
- c) Bill of Material.
- d) Delivery challan.
- e) E-way bill receipt.
- f) Dispatch document (RR/LR).

On confirmation & validity of above documents, store in charge will generate Provisional SR Note through ERP system immediately for receipt of material at stores thereof.

Where required by the Purchaser, the successful bidder must send the operation and maintenance manuals, test certificates, drawings etc. for the material ordered. These should be sent immediately after dispatch of material and a statement to that effect should be made in the invoice.

After successful RST of supplied each lot, store in charge will generate final SR note through ERP system immediately from receipt RST report at stores.

16) PAYMENT OF BILLS:**(a) Terms of payment:**

- a. The Bidder shall be paid 100% payment within 60 days from the date of receipt of material in good condition, against Stores Receipt Notes (S.R. Notes) issued by the concerned consignee.
- b. However, in respect of only those entities which qualify for 45 days payment period under the Micro, Small and Medium Enterprises Development Act, 2006, 100% payment of the Contract price will be paid within 45 days from the date of receipt of material at Consignee Store in good condition, against Stores Receipt Notes (S.R. Notes) issued by the concerned consignee.
- c. In respect of Micro, Small and Medium Enterprises, best efforts will be made for payment within 45 days from date of submission of invoice along with requisite documents after the delivery of entire lot. However, no claim for interest will be entertained in case of delay in payment beyond 45 days. The Micro, Small and Medium Enterprises who are ready to accept this payment term may only quote. No dispute in this regard will be entertained. After completion of order, the claims of whatsoever nature lodged after 30 days from the last date of payment will not be entertained.
- d. The payment shall be effected by A/C payee cheques / RTGS. Following documents as required in terms of order, will have to be forwarded to the G.M. (F&A-SB), Maharashtra State Electricity Distribution Co. Ltd., Prakashgad, Station Road, Bandra (East), Mumbai - 400 051 along with bills in triplicate to facilitate payment with a copy to the Chief Engineer of respective Zone.
 - (i) Original Tax Invoice (on the basis of rates accepted as per A/T) issued in accordance with the provisions of GST Invoice Rules.
 - (ii) Inspection and Test Certificate approval.
 - (iii) E Way Bill
 - (iv) Copy of Acceptance letter of Permanent Bank Guarantee / Security Deposit Certificate.
 - (v) Packing list.
 - (vi) Approved Bill of Material.
 - (vii) Certificate of having dispatched Operation & Maintenance Manual, copies of Test Certificates and approved drawings / Bill of Material to consignees wherever applicable.

The supplier shall forward the original R.R. / L.R. direct to the consignee along with relevant documents. The original bill shall be forwarded to The G.M. (F&A-SB), MSEDCL, Prakashgad, Bandra (E) and marked ORIGINAL. The bill should indicate the GST registration no. and date held by him under the GST Law. The Purchaser shall not be responsible for delay in payment of bills if the supplier fails to comply with any of the above requirements.

Supplier's copy of S.R. Note will be forwarded by the consignees through their respective Common Stores for supplier's record towards acknowledgement of receipt

of material. Accounts copy of S.R. Note will be forwarded by the respective Common Stores to G.M. (F&A-SB) for payment.

Wherever the payment is to be effected against Material Receipt Intimation (MRI) and if the supplier fails to forward the documents such as inspection report, bill of materials, approved drawings, etc. wherever required along with the invoice to the respective consignees and no payment shall be made against the said MRI.

The whole of the first lot as well as monthly lot when delivered in installments, the date of delivery and due date of payment will be counted after the receipt of the entire lot.

Any amount more than Rs. One Lakh can be transferred to the bank Account of the supplier electronically. For this RTGS (Real Time Gross Settlement) provision, following information is to be furnished by the bidder in the required documents of the online offer.

1. Name of the Company
2. Name of the Bank & Branch with address where the amount is to be transferred.
3. Current Account Number (15 digits)
4. RTGS No. / (IFSC Code) (Indian Financial Security Code)
5. MICR Code of the Bank
6. Company's email ID
7. Contact Name & Telephone No.

17) TAXES:

(A) Notwithstanding the fact that contract price is inclusive of GST:

- (i) GST shall be paid at actual on the basis of due date of delivery or actual date of supply whichever is lower against documentary evidence.
- (ii) Variation in GST on bought out items shall not be entertained.

(B) Structural changes in and due to 'Input Tax Credit' Scheme: -

- (i) In the event of any structural change occurred in the Input Tax Credit Scheme after the date of submission of the tender till the currency of the contract, the benefit out of such change shall be passed on to the purchaser.
- (ii) In the event of 'Input Tax Credit' being extended by the GST Law which were otherwise ineligible for claiming Input tax credit thereof, the seller should advise the purchaser about the additional benefits accrued or any variation thereof, through a letter containing such details and computation within such time as may be agreed between both the parties i.e. Supplier & MSEDCL.

18) DEDUCTION:

Any amount or amounts which become payable by the supplier to the purchaser under a particular contract, shall be deducted by the purchaser from any amount/amounts due or becoming due to the supplier under the same or any other contract and shall be adjusted against dues to the Purchaser.

=====

19) GUARANTEE:

Material offered shall be guaranteed for a period 66 months from the date of receipt at the consignee's Stores Center or 60 months from the date of commissioning, whichever is earlier. In case of failure of material within the above guarantee period, tenderer shall make available other new conditioned / repaired material / equipment, free of cost at Division / Stores for replacement within 45 days from the date of intimation from Division filter unit / Stores and lift the failed material / equipment for repair rejected material after replacement. For this purpose, bidder shall maintain spare stock in adequate quantity of ordered ratings of material / equipment. If the defective material is not replaced / repaired within the specified period as above, the Maharashtra State Electricity Distribution Company Ltd. shall retain an equivalent end cost of material plus 15% supervision charges from any of the bills of the supplier or encashing available performance bank guarantee submitted against guarantee period or through any available sources, till the return of the equipment. No interest will be paid on the amount so retained / recovered. In case of material / item not returned duly repaired within 45 days, penalty shall be imposed @ 0.5% per week or part thereof maximum up to 10% of the cost of undelivered material / equipment beyond specified time limit. In case of material / item not returned duly repaired within 5 months, total cost of the material / item along with penalty will be adjusted / recovered from the pending bills of the supplier or encashing available performance bank guarantee submitted against guarantee period or through any available sources with MSEDCL.

The guarantee period failed material / equipment will be made available at MSEDCL filter unit. Loading and unloading of guarantee period failed material / equipment should be arranged by the supplier.

The clause itself shall be the notice to the supplier about encashment of PBG to adhere to the timelines.

The outage period, i.e. the period from the date of failure till unit is repaired / replaced shall not be counted for arriving at the guarantee period.

Further, in case of repeated failures of equipments / material, the Purchaser reserves the right to debar / disqualify the supplier for future tenders / orders.

20) LIFTING OF MATERIALS:

I) LIFTING OF REJECTED/DAMAGED MATERIALS FROM STORES:

(a) On failure to replace or repair the transit damaged or rejected material within one month from the date of intimation as required under tender, it shall be deemed to have concluded that such material is finally rejected. The damaged / rejected material shall be lifted by the supplier within 30 days from the date of receipt of notice to that effect from the concerned consignee on reimbursement to the Purchaser of the cost of the material / equipment, if any, already paid in terms of payment clause in the contract and actual expenses incurred by the consignee towards handling, demurrage / wharfage / undercharges, freight, insurance premium etc. The Purchaser shall not be responsible in any case for the loss, destruction, damage, deterioration of the material after expiry of the said 30 days period.

(b) If the supplier fails to lift the material within this period, the material will remain with the Purchaser at the cost and risk of the supplier. Supplier shall, therefore, be liable to

pay ground rent @ 0.1% (Plus GST as may be applicable) per day of purchase cost of the material to be lifted from the date of intimation of rejection till the actual date of lifting.

- (c) The Purchaser will give 7 days' notice for lifting of rejected material and if not lifted, will be also free to Scrap / dispose of such material, after the period of said 37 days, by Public auction/Tender notice/Destruction as may be deemed fit and storage charges @ 0.1 % (Plus GST as may be applicable) per day of purchase cost will be recovered from the date of intimation of rejection of materials till the date of realization of the sale amount/physical removal of the material besides the actual expenses incurred as referred to at (a) above. The amount received from the sale of scrap/rejected material will be adjusted in the penalty.

Notwithstanding what is contended in the foregoing clauses, the supplier shall be liable to pay the Purchaser the cost and expenses incurred by the Purchaser, if any, including ground rent and the same shall be appropriated and recovered from the sale proceeds.

II) LIFTING OF FAILED MATERIAL / EQUIPMENT FROM DIVISION FILTER UNIT:

- a) If the supplier fails to lift the failed material within specified period, the material will remain with the Purchaser at the cost and risk of the supplier (By recovering end cost of failed transformer). The Purchaser will be also free to dispose of such material, after the period of 5 months from the date of intimation of failure by Public auction / Tender notice / Destruction as may be deemed fit or repaired departmentally and recovered cost will not be refunded to supplier.
- b) Process for lifting of rejected / damaged / failed materials from Divisions / Stores:
- i. The communication / correspondence shall only be made by specified e-mail id cemmcmsedcl@gmail.com by MSEDCL field offices / the supplier.
 - ii. As soon as the Material / Equipment is failed within guarantee period, the concerned Executive Engineer of O&M Division / Stores-in-charge shall inform the intimation of such failure immediately to Supplier as well as Material Management Department, Head Office on specified e-mail id in Format A (failure report).
 - iii. The Material Management Department will forward the format A to SB Section, Head office to withhold the payment equivalent to the cost of Material / Equipment with 15% supervision Charges from any of the bills of the supplier. If the supplier fails to return repaired transformer at concern O&M Division / Store within 45 days from the date of intimation, penalty to be imposed @ **0.5%** per week or part thereof maximum up to 10%.
 - iv. On receipt of Material / Equipment against replacement or repairs, the Executive Engineer, O&M Division / Store-in-charge will issue Format C (Rectification report) to concern supplier with copy to Material Management Department Head Office through specified e-mail id.
 - v. The supplier shall note that the guarantee period for the delayed period taken for replacement / repairing of Material / Equipment will be automatically extended.
 - vi. Material Management Department Head Office shall inform the SB Section, Head office to release the payment withheld against that Material / Equipment.

- vii. From the date of intimation, if supplier fails to return repaired Material / Equipment at O&M Division / concern store within 5 months, concerned Executive Engineer of O & M Division / Stores-in-charge shall inform the intimation of such failure immediately to Material Management Department, Head Office on specified e-mail id.
- viii. The Material Management Department Head Office shall forward the same to SB Section, Head office to recover the payment equivalent to the cost of Material / Equipment from any of the bills of the supplier with penalty to be imposed @ **0.5%** per week or part thereof maximum up to 10% for final recovery as per clause 19.

21) LIQUIDATED DAMAGES FOR LATE DELIVERY:

In case the materials are not delivered within the period stipulated in the order, the supplier shall be liable to pay at the discretion of the competent authority of the Purchaser, the liquidated damages to the Purchaser @ 1% per week or part of week on the value of delayed material / unexecuted quantity plus taxes as applicable, if any on the price subject to a maximum of cumulative ceiling of 10% reckoned on the contract value of such complete portion or section of the plant, equipment or material delayed and also the portion supplied which could not be brought into commission due to any part thereof not having been delivered in time. In addition to above if bidder fails to supply the material within contractual delivery period continuously for 3 lots, then the order shall be liable for cancellation.

Due consideration may be given in the levy of liquidated damages for reasons absolutely beyond the control of the supplier, for which documentary evidence shall be produced to the satisfaction of the competent authority of the Purchaser.

The Purchaser shall be entitled to deduct/recover the amount of liquidated damages from the current bill payable to the supplier or any other amount due or payable to him against this or any other contract.

For computing the liquidated damages for delayed supplies, the date of railway receipt or the date of receipt of materials at stores in case of road transport, shall be the date of delivery.

In case the Purchaser does not arrange for inspection of material within 10 days from the date of readiness of material wherever applicable, the period of more than 10 days will not be considered for levy of liquidated damages. For computing the period taken for inspection in such cases, the relevant date mentioned in the inspection certificate issued by the inspecting officer would be considered.

22) ORDER PLACED ON TIME PREFERENCE BASIS (WHEREVER APPLICABLE):

In case of order on time preference basis (i.e. orders given at higher rate on delivery period considerations only) if order is given at higher rate of L-2 (or L-3 etc.), then the payment at higher rates will be made provided the firm makes supplies within the stipulated time period. In case of delay in supplies, the payment will be made at the rates offered by L-1. In addition, Clause No.21 above for Liquidated Damages for late delivery will also be applicable. However, the quantity allocation for order under this clause shall be at the sole discretion of MSEDCL & the specified quantity allocation for this tender will not be applicable in this case.

23) FORCE MAJEURE CLAUSE:

If, at any time, during the continuance of this contract the performance in whole or in part by either party of any obligation under this contract shall be prevented or delayed by reason of any war, hostility, acts of the public enemy, civil commotion, sabotage, fires, floods, explosions, epidemics, quarantine restriction, strikes, lock-outs or acts of God (herein after referred to as

“events”), provided notice of happening of any such eventuality is given by either party to the other within 21 days from the date of occurrence thereof, neither party shall by reason of such event, be entitled to terminate this contract nor shall either party have any claim for damages against the other in respect of such non-performance or delay in performance; and deliveries under the contract shall be resumed as soon as practicable after such event has come to an end or ceased to exist, and the decision of the purchasing officer as to whether the deliveries have been so resumed or not, shall be final and conclusive, provided further that if the performance in whole or part of any obligation under this contract is prevented or delayed by reason of any such event for a period exceeding 60 days, either party may at its option terminate the contract PROVIDED ALSO that if the contract is terminated under this clause, the purchaser shall be at liberty take over from the contract at a price to be fixed by the purchasing Officer which shall be final all unused, undamaged and acceptable materials, bought out components and stores in course of manufacture in the possession of the contractor at the time of such termination or such portion thereof as the purchaser may deem fit accepting such material, bought out components and stores as the contractor may with the concurrence of the purchaser elect to retain.

24)ACCEPTANCE OF LOWER FORD RATE OFFERED IN SUBSEQUENT TENDER :

During contractual delivery period of supply, the quoted rates shall remain the same, however for same specification of material if the rates will receive lower in another subsequent tender in extended period of contract then it is binding on the supplier to supply the same material at lower rate for balance quantity of material i.e. in case if price bid of next subsequent tender of similar technical specification is opened and FORD rate found lower than the ongoing contracts this FORD rate shall be made applicable for the balance quantity beyond contractual delivery period. Further the purchaser reserves the right to allow the supplier to deliver the quantity or otherwise beyond the contractual delivery period.

However other stipulations of clause No. 23 of Section-II i.e. Annexure-A will remain unchanged.

25)PERFORMANCE OF CONTRACT:

The Purchaser will not be in any way liable for non-performance either in whole or in part of any contract or for any delay in performance thereof in consequence of strikes, shortage, non-availability of raw materials, combination of labour or workmen or lockout, breakdown or accident to machinery or accidents of whatever nature, failure on the part of the railways to supply sufficient wagons to carry essential raw materials etc. and finished products from the stores, subject to the provision and stipulation made in condition No. 21 as stated above i.e. Liquidated damages for late delivery.

26)CONTRACT PERFORMANCE DEPOSIT:

- 26.1 The supplier will have to furnish contract performance deposit as per Annexure - N in the form of unconditional & irrevocable BG within 15 days from the date of issue of LoA, as mentioned in Clause 26.2.
- 26.2 The contract performance deposit shall be an amount equal to 5% of the contract value and shall be valid for a period of 90 days beyond guarantee period of the last lot of the equipment supplied.
- 26.3 The contract performance deposit shall be refunded within 90 days from the date of expiry of the guarantee period of the equipment supplied. The purchaser shall not be

liable to pay any interest or compensation to the contractor for retaining the deposit after the end of the said period.

26.4 The contract performance deposit is intended to secure the performance of the contract for guarantee period of the equipment supplied. However, it is not to be construed as limiting the damages stipulated in other clauses of the contract.

27) POWER OF ATTORNEY:

It will be obligatory on the supplier to communicate the revocation of Power of Attorney, if any, after submission of offer till the execution of contract failing which the act/s & action done by the agent / representative shall be deemed to be the valid act/s & action of the bidder / supplier.

28) SETTLEMENT OF DISPUTE:

Permanent Dispute Resolution Committee (PDRC) comprises of Chief Engineer (MM Dept.), one member of Accounts Department and representative of supplier will resolve the dispute arise if any.

29) JURISDICTION:

Any disputes or difference arising under, out of or in connection with this tender or contract if concluded, shall be subject to the exclusive jurisdiction of the "Courts" in Mumbai.

30) TERMINATION OF CONTRACT

- 1) The decision of the Purchaser shall be final as regards the acceptability of the stores supplied by the supplier and the Purchaser shall not be required to give any reason in writing or otherwise at any time for the rejection of the stores/materials.
- 2) In case the contractor/supplier fails to deliver the stores/material or any consignment thereof within the contracted period of delivery as per delivery schedule or in case the stores/materials are found not in accordance with the prescribed specification and the performance of the supplied material is not found satisfactory, the Purchaser shall exercise in discretionary power either,
 - a) To purchase from elsewhere, after giving 15 days due notice to the contractor, at the risk of contractor, such stores/material not so delivered or other of similar description, without cancelling the contract in respect of consignment not yet due for delivery,
 - OR
 - b) To cancel the contract reserving Purchaser's right to recover damages Plus GST as may be applicable.
 - c) notwithstanding that the powers under (a) and (b) referred above are in addition to the rights and remedy available to the Purchaser under the General Law of India relating to contract.
 - d) Purchaser reserves right to recover damages against risk purchase or 10% value of non-supplied material plus applicable taxes, if any whichever is higher.

In the event of risk purchase of stores of similar description, the option of the Purchaser shall be final. In the event of action taken under (a) or (b) above, the supplier shall be liable for any loss which the Purchaser may sustain on that account

but the supplier shall not be entitled to any saving on such purchases made against default.

3) Further contract can be terminated in case of sub-standard /poor quality material.

31) DEBAR / BLACKLISTING OF MANUFACTURER:

In the event of fraudulent practices / non-compliance / non fulfillment of any obligation as required by MSEDCL at any stage of tendering or execution, the bidder is liable to be debarred / blacklisted at the discretion of MSEDCL.

32) TAX DEDUCTED AT SOURCE:

The purchaser shall deduct tax at source in accordance with the provisions of the laws as and when the same is notified.

SECTION-III

SPECIAL TERMS & CONDITIONS AND INSTRUCTIONS TO THE TENDERES

(A) SPECIAL TERMS & CONDITIONS:

The Tenderers are requested to take note of the following points in respect of commercial/Technical terms and conditions etc. Further if any of the following clauses is contradicting/deviating from the clauses appearing elsewhere in the tender specification, then the Clauses in the tender specification shall be treated as amended as under only. The offers not complying with this section shall be rejected.

I) Qualifying Requirements:

1. The bidder shall be an Original Equipment Manufacturer (OEM) and possess valid BIS license (If applicable) and BEE certificate (If applicable) as per clause no XIV.

Upload:

- a) BIS License and BEE certification.

2. The bidder should have experience for supply of similar or higher rating of material / equipment to any Electricity Distribution Utility, Electricity Distribution Franchisee or Public Sector Undertaking and should have executed orders of 30% of tender quantity for offered item during last three financial years.

Bidders who supplied the material in MSEDCLs projects viz; INFRA - II, IPDS, DDUGJY, DPDC, DDF, Non DDF, HVDS or any other scheme shall also be considered & bidder shall produce the order completion / quantity supplied certificate from concern Superintending Engineer (Infra/O&M).

Upload:

- a) Copies of orders executed by the bidder, and the Certificate from the purchaser with regards to successful execution of the order / supply of quantity for preceding three financial years.

- b) List of orders in hand.

3. For all tendered material, valid Type test certificates (If applicable) as per MSEDCLs technical specifications (Annexure-D) which are carried out within 5 years prior to the date of opening of tender from NABL accredited lab such as CPRI / ERDA shall be uploaded in the bid. Bids without the Type test certificates shall not be considered for further evaluation.

Upload:

- a) Type test certificates from NABL accredited lab such as CPRI/ERDA valid for a period of five years.

4. Average Annual Turnover – The Average annual turnover of last three financial years of the bidder shall be 30% of the tender estimated cost of offered item. The bidder has to submit the annual turnover certificate of the company of last three financial years duly certified by Chartered Accountant.

Upload:

- a) Documentary evidence showing annual turnover of last 3 years, certified by Chartered Accountant for preceding three financial years.

- b) Profit & Loss and Balance sheet certified by Chartered Accountant for preceding three financial years.

5. The bidder should have in-house testing facilities for conducting acceptance & routine tests in accordance with the procedures laid down in relevant IS /IEC amended up to date.

Upload:

a) List of in house manufacturing and testing facilities as well as quality control set up.

6. The bidder shall have ISO certification for quantity management system & environmental management system.

Upload:

a) ISO for quantity management system.

b) ISO for environmental management system.

7. The bidders who quoted under New Suppliers category are exempted from experience and turn over criteria. Bidder has to submit the Annexure-O regarding declaration of participation as New Supplier in the tender failing to which it will be presumed that bidder has participated in the tender as Regular Supplier. Once the Annexure-O is submitted in the offer it will not be changed at any stage of process and qualification will be done as per Annexure-O only.

Upload:

a) Annexure-O regarding declaration of participation as New Supplier in the tender.

8. Following Documents should be submitted by the bidder along with the bid.

Upload:

- The quantity offered for the supply of Distribution Transformers in the prescribed format as per schedule 'C'.
- Documentary evidence (for e.g. SSI/NSIC/Chartered Accountant Certificate) for manufacturing capacity to cover the quantity offered by the bidder and considering orders in hand.
- Udyam registration.
- Certificate from Chartered Accountant for not having controlling stake in more than one entity as per clause no VII.
- Annexure-F regarding declaration of legal litigations.
- Annexure-I regarding debar undertaking.
- Self-undertaking on bidders letter head for not approaching any one for undue influence.
- GST registration certificate.
- EMD receipt (Bank Guarantee or Demand Draft).
- Power of attorney.

(B) The quantity for procurement is as below.

| Item description | Total Qty. Reqd. (Nos.) | Estimated Cost (Cr.) |
|---|----------------------------|-------------------------|
| 11 KV, 25 KVA Distribution Transformers | 6,600 | 48.16 |

ANNEXURE - "B"

QUANTITY, PRICE AND DELIVERY PERIOD

ANNEXURE - "B" to be submitted online against commercial bid; attached separately

ANNEXURE 'C-I'

[To be submitted later on as per as per Clause XVIII (B) of Instructions]
CONFIRMATION FOR ACCEPTING ORDER BY MATCHING RATES WITH LOWEST ACCEPTABLE BIDDER

APPLICABLE FOR INDUSTRIAL UNITS FROM MAHARASHTRA ONLY Marketing Assistance and Purchase Preference to the units from Maharashtra (refer Clause XVIII of Instructions to Bidders):-

1. In case your unit is located in Maharashtra and the
(a) lowest acceptable rate received against the tender is from the unit outside Maharashtra, please confirm whether you are agreeable to accept order at that lowest acceptable rate limited to 50% (fifty percent) of our requirement.

APPLICABLE FOR ALL BIDDERS INCLUDING THOSE ELIGIBLE UNDER THE ABOVE CLAUSES:

1. Please confirm whether you are agreeable to accept
(b) order at the lowest acceptable rate received against the tender.

[Industrial units from Maharashtra can give option under 1(b) above for balance quantity]

Note:-

1. If the bidder gives the above confirmation for the quantity less than as indicated in Clause X (iii) of the Instructions to the Bidders, then the above confirmation shall not be acceptable.
2. Bidders may confirm matching for one or more items originally tendered.
3. Any withdrawal of confirmation for order by matching rate within validity of offer will render the entire offer invalid and shall be summarily rejected and Earnest Money Deposit shall stand forfeited.
4. A bidder will not be entitled to the benefit of offers by matching rates and will not be considered for orders if his original offer is rejected on the ground of ambiguity or because of not accepting /noncompliance of the terms & conditions of the tender.
5. In the above confirmation, if the bidder indicates any rate, then the above confirmation given by the bidder will not be considered as valid.

ANNEXURE- 'D'

TECHNICAL SPECIFICATION

As Indicated in E-Tendering

=====

ANNEXURE-O
(On bidders' letter head)

CONSENT FOR PARTICIPATION IN TENDER AS NEW SUPPLIER

I/We, have understood and checked the tender documents for supply of -----
----- and have not found any errors in them.

I/We hereby declare and confirm that we are participating in the tender no.....as New Supplier / Regular Supplier for particular rating as specified in the following table and agree to supply the material as per terms and conditions of the said tender.

| Sr. No. | Item Description | Regular Supplier (Yes/No) | New Supplier (Yes/No) |
|---------|--|---------------------------|-----------------------|
| 1 | 11 KV/0.433 KV, 25 KVA Distribution Transformers | | |

Note: 1) Bidder has to provide only one "Yes or No" against particular rating.

2) If for any particular rating bidder has given the option "Yes" for both the types (Regular & New Suppliers) then option for "Regular Supplier" will be considered and evaluation will be carried out as per Regular Suppliers criteria only.

3) If for any particular rating bidder has given the option "No" for both the types (Regular & New Suppliers) then it will be presumed that bidder has not quoted for that particular rating.

Yours faithfully,

Signature & Seal of company,

In the capacity of duly authorized to sign bids for and on behalf of

Address:

Annexure-F

(On supplier's Letter Head)

I, certify that,

The business dealings with our firm / agency M/s..... and its sister concern/Director/Partner/Proprietor have no any type of legal litigation against MSEDCL is pending in any court/Forum against/by the bidder or its sister concern/Director/Partner/Proprietor.

If it is found at any stage of tendering and order execution process then as per the tender conditions our offer will be rejected and I /We don't have any objection on the same.

I hereby certify that I am duly authorized representative of M/s.----- whose name appears above my signature.

Bidders Name:

Authorized representative's signature:

Authorized representative's Name:

Seal of the company

Name and address of the Bidder

Date:

Annexure-G

PRICE VARIATION CLAUSE

Not Applicable

Annexure - H

GUARANTEED TECHNICAL PARTICULARS

As indicated in E-Tendering GTP Parameter

Annexure- I

(On supplier's Letter Head)

I, certify that,

- a. The business dealings with our firm / agency M/s..... have not been debarred by any Ministry of GoI / GoM / state owned electricity distribution utility and still in force.

- b. The Directors, Proprietors, Partners, Employee(s) or owner of our firm / agency M/s..... have not been either jointly or severally guilty of malpractices in relation to its business dealings with the Government or MSEDCL during the last five years.

I hereby certify that I am duly authorized representative of M/s.-----
whose name appears above my signature.

Bidders Name:

Authorized representative's signature:

Authorized representative's Name:

Seal of the company

Name and address of the Bidder

Date:

Annexure- J

(On MSEDCL Letter Head)

Dispatch Instructions

BY R. P. A. D. / ORD. POST /E-MAIL

(SAP CONTRACT No: -----)

To,

M/s. -----

Email: -----

Sub: Supply of ----- against A/T No. ----- dt. -----

Ref: Final Inspection Call letter No. ----- dt. -----.

(I.W. Regn. No. ----- dt. -----)

Your readiness of material letter no. dtd.....

.....

Dear Sir,

With reference to the above, you are requested to dispatch transformers as given below:

| Sr. No. | Consigned to | Meant for Circle | Meant Zone for | Qty. in Nos. |
|---------|--------------|------------------|----------------|--------------|
| | | | | |

Further, you are requested to contact concerned S.E. (O&M) Circle / E.E. (O&M) Division / Addl. E.E. (MM Section) before dispatching / unloading the above material.

This is issued without prejudice to all other terms and conditions of the order.

Yours Sincerely,

Chief Engineer (M M Dept.)

Copy f.w.cs.to: The C.E., MSEDCL, -----.

Copy to:

The G.M. (F & A – SB), MSEDCL, Mumbai.

The E.E. (IW), MSEDCL, Mumbai.

The E.E. (O & M Division), MSEDCL, -----

The Addl.E.E. (MM Section), MSEDCL, -----

Annexure- K

List of Stores

| Sr. No. | Name of Stores | Address |
|---------|---------------------------------|---|
| 1 | Common Stores Ahmednagar | Nagar-Pune Road, Opp. Arti Hotel, Kedgaon, Ahmednagar. |
| 2 | Common Stores Airoli | Power House, Thane-Belapur Road, Airoli, Navi Mumbai. |
| 3 | Common Stores Akola | Major Store Babhulgaon NH No 6 Akola. |
| 4 | Common Stores Amravati | Major Store MSEDCL Power House, Mulshi Road, Amravati. |
| 5 | Common Stores Aurangabad | MIDC Plot No. J-13, Opp. Garware Stadium, Naregaon Phata, Chikhalthana, Aurangabad. |
| 6 | Common Stores Beed | Near 132 kV Sub-station, Idgah Nagar, Nalvandi Naka, Beed. |
| 7 | Common Stores Chandrapur | Near Vidyut Bhavan, Bagala Chaowk, Babu Peth, Chandrapur. |
| 8 | Common Stores Jalgaon | Old MIDC Area, Behind Ajanta Lawns, Ajanta Road, Aurangabad Highway, Jalgaon. |
| 9 | Common Stores Kalyan (Netivali) | MIDC Phase 1, Near Tata Power House, Kalyan - Dombivali Road. |
| 10 | Common Stores Kamptee | Maldhakka Godown, Behind Railway Station Kamatee, Nagpur. |
| 11 | Common Stores Khamgaon | Manav Dharm Bld. Near 132 kV Sub-Station, Shegaon Road, Khamgaon, Dist. Buldhana. |
| 12 | Common Stores Kolhapur | Kaneri Math Road, A/P Gokulshirgaon, Tal. Karveer, Dist. Kolhapur. |
| 13 | Common Stores Kudal | Malwan Road, MIDC Pinguli-Nerur, Kudal, Sidhudurg. |
| 14 | Common Stores Latur | MIDC Plot No. P-21/P, In Front of Kirti Gold Oil Mill, Latur. |
| 15 | Common Stores Mulshi | Phursungi-Saswad Road, Near Overhead Bridge, Mulshi/ Phursungi, Dist. Pune. |
| 16 | Common Stores Nanded | Taroda Naka Main Road, Nanded. |
| 17 | Common Stores Nashik | Aringale Plot, Hanuman Nagar, Jail Road, JunaSaykheda Road, Panchak, Nasik. |
| 18 | Common Stores Osmanabad | Near MSEDCL Rest House, Tuljapur Road, Osmanabad. |
| 19 | Common Stores Palghar | Near 33/11 kV Sub-Station, MSEB Coloney, Boisar Road, Palghar. |
| 20 | Common Stores Parabhani | Old Power House Jintur Road, Parbhani. |
| 21 | Common Stores Ratnagiri | MIDC Area Mirjole, Kuwarbav, Ratnagiri. |
| 22 | Common Stores Sangli | Near Walchand Engineering College, VishramBaug, Sangli. |
| 23 | Common Stores Satara | A/P Satara, Tal. Koregaon, Dist. Satara. |
| 24 | Common Stores Solapur | Plot No P-4, MIDC Chincholi, Behind Post Office, Solapur |
| 25 | Common Stores Tumsar | Near Power House, Nakaq Dongari Road, Old Bus Stop, Tumser, Bhandara. |
| 26 | Common Stores Yavatmal | MIDC Lohara, Yavatmal. |

=====

ANNEXURE – M

BANK GUARANTEE FORMAT

EARNEST MONEY DEPOSIT BANK GUARANTEE AGAINST TENDER

B.G. No. & DATE:

The Bank of _____(full address of Branch) hereby agree unequivocally and unconditionally to pay, at Mumbai within 48 hours, on demand in writing from the MAHARASHTRA STATE ELECTRICITY DISTRIBUTUION CO. LTD. (name of the company formerly known as M.S.E.B.) on behalf of M/s _____(Address as per MSEDCL REGISTRATION) who have tendered and/or contracted or may tender or contract hereafter for supply of materials. Equipments or services to the MAHARASHTRA STATE ELECTRICITY DISTRIBUTUION CO. LTD. against Tender No. ----- dated ----- total value of Tender is Rs. -----

This agreement shall be valid and binding on this Bank up to and including validity (date) and shall not be terminable by notice or any change in the constitution of the Bank or the firm of contractors or any other reasons whatsoever and our liability hereunder shall not be impaired or discharged by any extension of time or variations or alternations made given conceded or agreed with or without our knowledge or consent by or between parties to the said within written contract. The validity of this Bank Guarantee will be extended by us for the further period of six months, one month prior to its present validity period at the request of MAHARASHTRA STATE ELECTRICITY DISTRIBUTUION CO. LTD.(name of the company-formerly known as M.S.E.B.).

In case of any dispute arising out or it connection with the extension or encashment of Bank Guarantee, the Courts in Mumbai will have jurisdiction.

Our liability under this Guarantee is restricted to Rs.-----/- (Rupees----- only). Our Guarantee shall remain in force until (date). Unless a suit or action to enforce a claim under the guarantee is filed against us within six months from the aforesaid date, all your rights under the said guarantee shall be forfeited and we shall be relieved and discharged from all liability there under.

Place:

Date:

Sign-----

For-----

(Banker’s Rubber Seal & Bank Code No. of signatory)

Please note that:

1. The value of non-judicial stamp paper for this Bank Guarantee is Rs.200/- should be purchased in the name of Guarantor Bank.
2. The Bank Guarantee should be furnished from any Scheduled Bank/Nationalized Bank.
3. Please state the full and complete postal address of the Bank undertaken the guarantee.
4. The Bank Guarantee may be valid as per terms and condition of A.T.
5. B.G. should be submitted along with covering letter of Bank.

ANNEXURE – N

BANK GUARANTEE FORMAT

FORM OF BANK GUARANTEE FOR THE PERFORMANCE OF THE EQUIPMENT

B.G. No.& Date:

This deed of Guarantee is made thisday of.....

By.....branch having at H.O. at..... (here in after called “the Surety” which expression shall where the context so admits include its permitted assign) in favour of MAHARASHTRA STATE ELECTRICITY DISTRIBUTUION COMPANY LTD. (name of the company formerly known as M.S.E.B.) being a government company formed as per the provisions of the Maharashtra Electricity Reforms Transfer Scheme. 2005 having its registration no. U40109 MH 2005 SGC 153645 (here in after called the “Creditor” which expression shall include its permitted assigns). WHERE AS M/s. (Name of Party)..... (Postal address as per A/T) have entered into a contract to supply (Name of Material) to the MAHARASHTRA STATE ELECTRICITY DISTRIBUTUION COMPANY LTD. (Name of the Company formerly known as M.S.E.B.). vide contract No.dtd.....on the terms and conditions in the said contract. (here in after for brevity sake called “the said contract”).

In accordance with terms of the said contract, the creditor has agreed to pay to M/s.....(Name of Party)..... the said sum representing the 5% of the total contract price for the Rs...../- and WHEREAS M/s. (Name of Party).....is required under the terms of contract to furnish a Bank Guarantee for Rs...../- (Rupees:.....Only) the said sum representing the 5 %price as given in the said contract.

The surety as he requests of M/s.(Name of Party).... has agreed to give this guarantee.

NOW THEREFORE THIS DEED WITNESS AS FOLLOWS:

1. In consideration of the creditor agreeing to make to the debtor at Mumbai the payment of Rs..... (Rupees.....only) being the value of 10% of the total contractprice as given in the said contract on supplying the complete material as per the contract by the debtor failing which the surety does undertake to pay to the creditor on demand such amount of amounts as the surety may be called upon to pay not exceeding in the aggregate sum of Rs./- (Rupees.....only).
2. The surety hereby guarantee to the creditor the due performance and observance by the debtor of the terms and conditions of the contract.
3. The surety also agrees that it shall not during the currency of the guarantee herein given or during the period of its execution revoke the same even by giving notice to the creditor.
4. On account of the non-fulfillment of the contractual obligation by the debtor or in case the surety or contractor do not renew this guarantee bond as herein provided, the surety will on simple demand from the creditor, pay at Mumbai the creditor, the sum of Rs.....(Rupeesonly) as indicated under clause -1 above, without demure and without the creditor to invoke any legal remedy that may be available to them to compel the surety to pay the same even if the debtor consider such demand of the creditor unjustified.
5. The surety agrees and declares that notwithstanding anything contained in Section 133 to 135 of the Indian Contract Act 1872 (IX of 1972) or any other rule of law or equity in the

view of any variance in the terms of the said contract shall not operate as a discharge of his obligations hereunder or shall any composition made by the creditor with debtor in respect of any breach of the terms and conditions of the said contract operate as a discharge of the surety's obligation and surety further expressly agrees and declares that though as between the creditor and surety, the surety shall be liable for sum payable or falling due hereunder equally with the debtor and the surety save as otherwise herein provided hereby waives all his rights which he might as guarantor be entitled to claim and enforce.

- 6. The decision of the creditor that any sum has become payable shall be final and binding on the surety.
- 7. The guarantee shall come into force on supply of material shall remain in force till the end of(date)The surety, at the request of the creditor shall extend the validity of the Bank Guarantee for a further period of 12 months, one month prior to its present validity period.
- 8. In case of any dispute arising out of or in connection with the extension or encashment of the Bank Guarantee, the courts in Mumbai will have the jurisdiction.
- 9. The guarantee herein contained shall not be effected, by the change in the constitution of the surety or the debtor.
- 10. Our liability under this guarantee is restricted to Rs.(Rupees.....only) and our guarantee shall remain in force until (Date....) unless a claim under this guarantee is lodged with us within six months from the date of expiry of guarantee i.e. on or before ..(date)...all your rights under this guarantee shall be forfeited and we shall be relieved and discharged from all our liabilities there under.

IN WITNESS WHERE OF THE surety has executed this deed in presence of

Place: Signature.....

Date: for.....

(Banker's Rubber Seal & Code No. of signatory)

Witnessed (2 witness is required from bank only)

1) Name & Address

Signature

2) Name & Address

Signature

Please Note:

- 1. The value of non-judicial stamp paper for this bank guarantee is Rs. 200/- should be purchased in the name of Guaranteed Bank.
- 2. The bank guarantee should be furnished from any Scheduled bank
- 3. Please state the full and complete postal address of the bank undertaking the guarantee.
- 4. B.G. may be valid as per terms of A/T including guarantee period of material.
- 5. B.G. should be submitted along with covering letter of Bank.

SCHEDULE C

Quantity Offered at Column No. 6 of Annexure-‘B’ (Price Schedule):

| Sr. No. | Item Code | Material Description | Quantity Tendered in Nos. | Quantity Offered at Column No. 6 of Annex-‘B’ (Price Schedule) in Nos. |
|---------|-----------|----------------------|---------------------------|--|
| 1 | 2 | 3 | 4 | 5 |
| 1 | | | | |

Seal & Signature of Supplier

Format for Inspection Call Readiness of Material

Ref. No.

Date:

To,
The CE (MMD),
Prakashgad, Bandra (E),
Mumbai - 400051.

Sub: Inspection Readiness of material against A/T No. ----- dated. ----- for Supply of -----.

.....

1. Brief description of the material Offered for inspection:
2. Reference of drawing Approval :
3. a) Reference of approval of type test:
b) Reference of approval of balance type test (If applicable):
4. Whether it is a joint inspection with Testing SE (TQA) etc. (if applicable):
5. a) Whether Performance Deposite has been paid against the order:
b) if paid, please give details:
6. Sr. No. of the items as per A/T:
7. Total Quantity of the items Ordered:
8. Total quantity of the items inspected so far:
9. a) Quantity monthly committed in delivery schedule:
b) Lot No. for which the Quantity is offered for inspection now:
c) Due date of delivery as per A/T for offered quantity:
10. Date of readiness of Material:
11. Complete address of the factory where materials is to be inspected:
12. Name of the person to be contacted in connection with inspection & his Office/Factory/Residence Tel. No.:
13. Staggering holiday of Factory/Office at the place of inspection:
14. a) Whether Dispatch Instructions are available (Say Yes or No):
b) Quote Letter No.:
c) Brief destination & Qty. per consignee of this present lot offered:
15. Last visit of our Inspecting Officer:
16. a) Whether the entire material is dispatched against last inspection. (Our EE[IW] will ensure before inspection of this lot that the earlier inspected lot is already dispatched)
b) Quantity dispatched
17. Further programme of production Quantity likely to be offered & by what date:

Authorized Signature
For (Name of the Firm).

Format A

(Intimation of failure of Transformer)



.....
Ref. No.

Date:

To,
 Name & address of the firm

Sub: Failure of -----KVA, -----kV Dist. Transformer within Guarantee Period.

Dear sir,

This is to inform that -----KVA, -----kV Dist. Transformer supplied by you is failed within Guarantee Period.

You are therefore requested to depute your service representative at -----store to attend the repairing of the same at the earliest.

The detail of Transformer is as below:

| Sr. No. | Material and stores | Purchase order reference | Unit rating with class | Sr. No. of unit make failure | Date of commission | Date of failure | Load details & probable cause of | Present location of faulty unit | Remarks |
|---------|---------------------|--------------------------|------------------------|------------------------------|--------------------|-----------------|----------------------------------|---------------------------------|---------|
| | | | | | | | | | |

EXECUTIVE ENGINEER
 (O&M) Division

Copy s.w.r. to

Copy to :

Format C

(Intimation of replacement / repairs of transformer & successful commissioning)



.....
Ref. No.

Date:

To,
Name & address of the firm

Sub: Rectification/Repair of Dist. Transformers under Supplier Guarantee period.

Ref: This Office Format A Letter No.----- dt. -----
.....

Following transformer is repaired as per our satisfaction on dt.----- by your representative or departmentally and cost of repairs is Rs. -----Which is inclusive of normative charge Transformer Details are as below,

1. Sr. No.:
2. Make:
3. Capacity:
4. Date of Failure :
5. Date of repairing :
6. P.O. Reference No.:
7. Store Centre from where lifted:
8. Reasons for failure :
9. Details of rectification:

Submitted for your further needful please.

EXECUTIVE ENGINEER
(O&M) Division

Copy s.w.r. to

Copy to :

Annexure 'B'(Price Schedule)

| Sr.No | Item Code | Material Description | Unit | Quantity Required | HSN | Quantity Offered | Unit ExWorks including packaging charges but excluding duties & taxes etc (In Rupees) | Freight Charges Per Unit (In Rupees) | Transit Insurance Charge s Per Unit (In Rupees) | Integrated GST for outside State Transaction on (Ex-Works Price+Freight Charges + Transit Insurance Charges)(In Rupees) | Central GST for within State Transaction on (Ex-Works Price + Freight Charges + Transit Insurance Charges)(In Rupees) | State GST for within State Transaction on (Ex-Works Price + Freight Charges + Transit Insurance Charges)(In Rupees) | Free Door Delivery Price Per Unit by Road upto Destination/Stores/Sub Station (In Rupees) |
|-------|-------------|--|------|-------------------|----------|------------------|--|---------------------------------------|--|--|--|---|---|
| 1 | 2 | 3 | 4 | 5 | 6 | 7 | 8 | 9 | 10 | 11 | 12 | 13 | 14=(8+9+10+11+12+13) |
| 1 | 20113132593 | 25KVA11/0.4 33KV3PHDIS TTRANFSTA R1/EEL-1 | NO | 6600 | 85042100 | | | | | | | | |

Delivery Details

[Delivery must in the units specified for the items as per Price Schedule]

First lot of ___ in assorted sizes will be delivered within 2 Months from the date of LOA Award. After this period supply will be completed at the rate of ___ in assorted sized per month

Confirmation Details

We Confirm The Following :

I) Goods and Services Tax(GST) i.e Integrated GST / (Central GST+ State GST):

The GST is included in our prices quoted in price bid (Central GST+ State GST) for within Maharashtra State/Integrated GST for outside State and we shall not charge any additional amount towards Integrated GST / (Central GST+ State GST), during currency of contract except statutory variation by Central / State Government in normal (full) rate of Integrated GST / (Central GST+ State GST), in case of Integrated GST / (Central GST+ State GST) Rate is increased. In case the Integrated GST / (Central GST+ State GST) is decreased than the rate indicated in the price bid, the benefits of the reduction in the Integrated GST / (Central GST+ State GST) shall be passed on to the Purchaser. The increase in the Integrated GST / (Central GST+ State GST) rate due to increase in turnover during the contractual delivery period shall not be charged to the Purchaser. If the Integrated GST / (Central GST+ State GST) is not payable at present, we shall not charge the same, if it becomes applicable during the currency of contract due to expiry / withdrawal of tax concessions and incentives during the currency of contract except for statutory variation by Central / State Government.

(i) Necessary documentary evidence for the GST claimed by us shall be submitted along with the bills.

(ii) We here by declare that while quoting the price in the Price Bid, we have taken into account the entire credit on inputs available under the GST Act.

Technical Specification Item: 25KVA11/0.433KV3PHDISTTRANFSTAR1/EEL-1



Maharashtra State Electricity Distribution Company Limited

SPECIFICATION NO.MMC: MSC/DB/01 /2018

TECHNICAL SPECIFICATION

For

25KVA11/0.433KV3PHDISTTRANFSTAR1/EEL-1

For

DISTRIBUTION SYSTEM

IN

MSEDCL



TECHNICAL SPECIFICATION OF 16 AND 25kVA, 11/0.433 kV LEVEL-1 THREE PHASE, NON SEALED TYPE DISTRIBUTION TRANSFORMERS OUTDOOR TYPE OIL IMMERSSED WITHOUT CSP FEATURE.

MATERIAL SPECIFICATIONS CELL

TECHNICAL SPECIFICATION

OF

16 kVA AND 25kVA, 11/0.433 kV LEVEL-1 THREE PHASE, NON SEALED TYPE DISTRIBUTION TRANSFORMERS OUTDOOR TYPE OIL IMMERSSED WITHOUT CSP FEATURE



TECHNICAL SPECIFICATION OF 16 AND 25kVA, 11/0.433 kV LEVEL-1 THREE PHASE, NON SEALED TYPE DISTRIBUTION TRANSFORMERS OUTDOOR TYPE OIL IMMERSED WITHOUT CSP FEATURE.

| I N D E X | |
|---------------|--|
| Clause No. | Contents |
| 1 | Scope |
| 2 | System Particulars |
| 3 | Service Condition |
| 4 | Applicable Standards |
| 5 | Specific Technical requirement |
| 6 | Design & Construction |
| 6.1 | Core |
| 6.2 | Windings |
| 6.3 | Losses |
| 6.4 | Insulation Material & Clearances |
| 6.5 | Impedance Value |
| 6.6 | Tank |
| 6.7 | Off Load Taps |
| 7 | Efficiency |
| 8 | Heat Dissipation |
| 9 | Total minimum oil volume |
| 10 | Conservator |
| 11 | Breather |
| 12 | Terminals |
| 13 | Bushing and connections |
| 14 | Internal Connections |
| 15 | Tank base channel |
| 16 | Terminal Marking Plate & Rating Plate |
| 17 | Fittings & Fasteners |
| 18 | Lightning Arrestor |
| 19 | Transformer Oil |
| 20 | Tests & Inspection |
| 21 | Challenge Testing |
| 22 | Type Test Report Submission |
| 23 | Drawings & Calculation Sheet |
| 24 | Rejection |
| 25 | Cleaning & Painting |
| 26 | Standard Guaranteed Technical Particulars |
| 27 | Testing facilities |
| 28 | Submission of Routine Test Certificate |
| 29 | Stage Inspection |
| 30 | Final Inspection |
| 31 | Testing of all distribution transformers for losses at 50 %load and 100 % load |
| 32 | Random Sample Testing |
| 33 | Inspection & Testing of Transformer Oil |
| 34 | Quality Assurance |
| 35 | Qualifying Requirements |
| 36 | Performance Guarantee |
| Annexure-I | Air Pressure Test |
| Annexure-II | Temperature Rise Test |
| Annexure- III | Guaranteed Technical Particulars |
| Annexure-IV | Technical specification for QR Code generation |
| | Indicative Drawings |



TECHNICAL SPECIFICATION OF 16 AND 25kVA, 11/0.433 kV & 22/ 0.433 kV LEVEL-1 THREE PHASE, NON SEALED TYPE DISTRIBUTION TRANSFORMERS OUTDOOR TYPE OIL IMMERSED WITHOUT CSP FEATURE.

1.0 Scope

This specification covers design, manufacturing, testing and delivery of 16 and 25 kVA, 11kV/0.433 kV & 22kV/0.433kV, EE Level-1 three phase, Non- Sealed type distribution transformers outdoor type oil immersed without CSP feature, Oil Natural Air Natural (ONAN) suitable for 11 kV, 50 Hz, Distribution system.

The equipment offered shall be complete with all parts necessary for their effective and trouble-free operation. Such parts will be deemed to be within the scope of the supply irrespective of whether they are specifically indicated in the commercial order or not.

It is not the intent to specify herein complete details of design and construction. The equipment offered shall conform to the relevant standards and be of high quality, sturdy, robust and of good design and workmanship complete in all respects and capable to perform continuous and satisfactory operations in the actual service conditions sufficiently long life in service as per statutory requirements.

The design and constructional aspects of materials shall not withstanding any anomalies, discrepancies, omissions, incompleteness, etc. in these specifications and will be subject to good engineering practice in conformity with the required quality of the product, and to such tolerances, allowances and requirements for clearances etc. as are necessary by virtue of various stipulations in that respect in the relevant Indian Standards, IEC standards, I.E. Rules, I.E. Act and other statutory provisions.

The Bidder/supplier shall bind himself to abide by these considerations to the entire satisfaction of the purchaser and will be required to adjust such details at no extra cost to the purchaser over and above the tendered rates and prices.

Tolerances:

The tolerance of guaranteed performance figures shall be as specified in the (Part-I) table 1 of latest issue of IS 2026 except losses or relevant International Standard except wherever specified otherwise in this specification.

2.0 System Particulars:

The transformers shall be suitable for outdoor installation with following system particulars and they should be suitable for service under fluctuations in supply voltage as permissible under Indian Electricity Rules.

- I. Nominal System Voltage: 11 kV or 22kV
- II. Corresponding Highest System Voltage: 12kV or 24kV
- III. Rated Basic Insulation Level: 75 KVp or 125kVp
- IV. Neutral earthing: Solidly earthed
- V. Frequency: 50 Hz with $\pm 3\%$ tolerance
- VI. Number of Phases: 3

3.0 Service Conditions

- 3.1 Equipment supplied against the specification shall be suitable for satisfactory operation under the following tropical conditions:-



TECHNICAL SPECIFICATION OF 16 AND 25kVA, 11/0.433 kV & 22/ 0.433 kV LEVEL-1 THREE PHASE, NON SEALED TYPE DISTRIBUTION TRANSFORMERS OUTDOOR TYPE OIL IMMERSED WITHOUT CSP FEATURE.

| | | |
|------|--|---|
| i | Max ambient air temperature | 50 Deg. C |
| ii | Max relative humidity | 100 % |
| iii | Max annual rainfall | 1450 mm |
| iv | Max wind pressure | 150 kg/sq.m. |
| v | Max altitude above mean sea level | 1000 mtrs. |
| vi | Isoceraunic level | 50 |
| vii | Seismic level (Horizontal acceleration) | 0.3 g. |
| viii | Climatic Condition | humid tropical climate conducive to rust and fungus growth. |
| ix | Reference Ambient Temperature for Temperature rise | 50 DegC |

- 3.2 The climatic conditions are prone to wide variations in ambient conditions and hence the Distribution Transformer shall be of suitable design to work satisfactorily under these conditions.
- 3.3 The Distribution Transformer shall be for use in moderately hot and humid tropical climate conducive to rust and fungus growth.
- 3.4 The Distribution Transformer shall be mark with standard mark governed by BIS as per clause 13.4 of IS 1180(Part 1):2014]
- 3.5 The Distribution Transformer shall bear star-1 rating label approved by BEE (Bureau of Energy Efficiency).
- 3.6 The Distribution Transformer shall bear EE level 1 (star 1 of BEE) ratings label approved by BIS (Bureau of Indian Standard) as per IS:1180 (Part1):2014 (Amendment-1 August 2016).
- 3.7 The Bidder/ Manufacturer shall possess the BIS license for offered product.
- 3.8 The Bidder/ Manufacturer shall possess the BEE certification for offered product.

4.0 APPLICABLE STANDARDS:-

- 4.1 The design, manufacture and performance of the Distribution Transformer shall comply with all currently applicable statutes, regulations and safety codes. Nothing in this specification shall be construed to relieve the bidder off his responsibilities.
- 4.2 The Distribution Transformers shall conform to IS: 1180 (Part 1): 2014 amended up to date or other International Standards for equal or better performance.
- 4.3 The applicable standards are as follows:

| Sr.No. | IS number | IS name |
|--------|---|--|
| i | IS:1180(Part-1) : 2014 with (Amendment-1 to 4) | Outdoor type oil immersed distribution transformers up to and including 2500 kVA, 33kV |
| ii | IS:2026(Part I to IV) | Specification for power transformer |
| iii | IS:335/1993 | New insulating oil-Specification(fourth revision) |



**TECHNICAL SPECIFICATION OF 16 AND 25kVA, 11/0.433 kV & 22/ 0.433 kV LEVEL-1 THREE PHASE,
NON SEALED TYPE DISTRIBUTION TRANSFORMERS OUTDOOR TYPE OIL IMMERSSED WITHOUT CSP
FEATURE.**

| Sr.No. | IS number | IS name |
|--------|--|--|
| iv | IS/IEC 60137, IS: 7421-1988, IS:3347 (Part-I/Sec-2)-1979, IS:3347 (Part-I /Sec-1)-1982 amended up to date | Bushing |
| v | IS 5 | Colours for ready mixed paints and Enamels. |
| vi | IS 13730 (Part-27)1996 | Specification for particular types of winding wires. |
| vii | IS: 3073/1974, IS: 3070(Part- II) | Specifications for L.A's |
| viii | CEA Guidelines August -2008 | Manual on transformers |
| ix | Gazette notification by Ministry of Power dated 16.12.2016 | Revised losses of distribution transformers |

44 In case of conflict arising out to variations between the applicable standard and the standards specified herein the provisions of this specification should prevail.

5.0 Specific Technical requirement:

5.1 Standard kVA Ratings:-

The standard ratings for three phase transformer shall be 16 & 25kVA as per IS 1180 (Part-I):2014

A) Nominal voltage ratings

I. Primary voltage: 11 kV or 22kV

II. Secondary voltage: 0.433 kV

B)Winding connections:-

i. H.V. Winding: Delta (Δ)

ii. L.V. Winding: Star (Y)

so as to produce a positive phase displacement of 30 degrees from the primary to the secondary vectors of the same phase. The neutral of the L.V. winding shall be brought out to a separate insulated terminal. The voltage group shall be Dyn-11 (IS 2026 Part I).

5.2 Temperature Rise:

i The temperature rise for top oil over an ambient temperature of 50°C should be 35°C maximum [measured by thermometer in accordance with IS 1180 (Part 1) & IS 2026 (Part 2)]

ii Temperature rise for winding over an ambient temperature of 50° C should be 40° C maximum [measured by resistance method in accordance with IS 1180 (Part 1) IS 2026 (Part2)]



**TECHNICAL SPECIFICATION OF 16 AND 25kVA, 11/0.433 kV & 22/ 0.433 kV LEVEL-1 THREE PHASE,
NON SEALED TYPE DISTRIBUTION TRANSFORMERS OUTDOOR TYPE OIL IMMERSSED WITHOUT CSP
FEATURE.**

5.3 No load voltage ratio:-

The no load voltage ratio shall be 11000/433 Volts & 22000/433 Volts.

6.0 **Design & construction**

- a. The spring washers must be used for fixing core with tie rod.
- b. Core base & bottom Yoke shall be supported with 75 mm X 40 mm X6 mm MS Channel with proper bolting. The core assembly shall be fixed by four locking bolts.
- c. The maximum flux density in any part of the core and yoke at rated voltage and frequency shall be such that the flux density with +12.5 % combined voltage and frequency variation with rated voltage and frequency does not exceed 1.9 Tesla. Flux density should not be more than 1.69 Tesla at rated voltage and frequency.
- d. Limit of no load current shall be 3% of full load current of respective winding at rated voltage.

6.1 **Core**

i The core shall be stacked/ wound type.

a) For Stack core :- The core shall be of high grade cold rolled grain oriented (C.R.G.O) annealed steel lamination having low loss and good grain properties, coated with hot oil proof insulation, bolted together to the frames firmly to prevent vibration or noise. All core clamping bolts shall be effectively insulated. The complete design of core must ensure permanency of the core losses with continuous working of the transformers.

b) For Wound core :-

The core shall be 'C' type construction of core high grade cold rolled grain oriented (C.R.G.O.) annealed steel lamination having low loss and good grain properties, coated hot oil proof insulation. The complete design of core must ensure permanency of the core losses with continuous working of the transformers. The core material shall not be brittle in case of CRGO material.

Core clamping for C.R.G.O. Wound core type transformers shall be as follows:

- a. Core clamping shall be with top and bottom U- shaped core clamps made of sheet steel clamped.
- b. M.S. core clamps shall be painted with oil-resistant paint.
- c. Suitable provision shall be made in the bottom core clamp / bottom plate of the transformer to arrest movement of the active part.
 1. Core shall be clamped by minimum 12 mm diameter MS Tie Rods.
 2. Compliance of CRGO Electrical steel as per IS 3024 [as mentioned in Cl.No.9.1 (a) of IS 1180(Part1):2014] shall be ensured through test certificate of the supplier.

ii The grade of core laminations shall be M4 or better (CRGO).

iii The successful bidder shall be required to submit the manufacturer's test report showing the Watt Loss per kg and the thickness of the core lamination, to ascertain the quality of Core materials.



TECHNICAL SPECIFICATION OF 16 AND 25kVA, 11/0.433 kV & 22/ 0.433 kV LEVEL-1 THREE PHASE, NON SEALED TYPE DISTRIBUTION TRANSFORMERS OUTDOOR TYPE OIL IMMERSSED WITHOUT CSP FEATURE.

The purchaser reserves the right to get sample of the core material tested at any Government recognized laboratory.

- iv The transformer core shall not be saturated for any value of V/f ratio to the extent of 112.5% of the rated value of V/f ratio (i.e. 11000/50 or 22000/50) (due to combined effect of voltage and frequency) up to 12.5% without injurious heating at full load conditions and will not get saturated. The bidder shall furnish necessary design data in support of this situation.

- v Flux density:-

The maximum flux density in any part of the core and yoke at rated voltage and frequency shall be such that the flux density with +12.5 % combined voltage and frequency variation with rated voltage and frequency does not exceed 1.9 Tesla. Flux density at rated voltage and frequency should not be more than 1.69 Tesla for CRGO core.

- vi The No Load Current at rated voltage shall not exceed the percentage as given below. The no load current of 16kVA & 25 kVA transformers shall not exceed 3% the full load current and will be measured by energizing the transformer at rated voltage and frequency. Increase of 12.5 percent of rated voltage shall not increase the no load current by 6% of full load current. (As per IS 1180 (Part1):2014).

Number of steps of CRGO stacked core shall be minimum of stack core transformer

| Sr. No. | Rating (kVA) | Number of steps for stack core |
|---------|--------------|--------------------------------|
| 1 | 16 | Min. 5 standard steps |
| 2 | 25 | Min. 5 standard steps |

- vii The CRGO core used for 16 KVA & 25 KVA transformers shall have ISI mark and it shall be confirmed/checked by inspector at the time of inspection.

6.2 Winding:-

The material for winding shall be Aluminum for 11kV and 22 KV class transformers.

- i. Super enameled of thermal grade of 220 degree C or Double paper covered Aluminum conductor shall be used for HV/LV winding for 16KVA, 25KVA Distribution Transformers for both 11 kV & 22kV class transformers.
- ii. Current Density:- Current density for HV and LV winding should not be more than 1.3 A/sq. mm (including tolerance) for Aluminum.
- iii. L.V. Neutral formation shall be at side wall of tank.
- iv. No of HV coil per phase shall be as below
 - a) CRGO stack core – Minimum 2 coils per phase.
 - b) CRGO wound core- Single coil per phase.

6.3 Losses:

The total losses (no-load + load losses at 75 deg. Centigrade) at 50% of rated load &



TECHNICAL SPECIFICATION OF 16 AND 25kVA, 11/0.433 kV & 22/ 0.433 kV LEVEL-1 THREE PHASE, NON SEALED TYPE DISTRIBUTION TRANSFORMERS OUTDOOR TYPE OIL IMMERSED WITHOUT CSP FEATURE.

total losses at 100% of rated load shall not exceed the maximum total loss values indicated as below:-

for 11kVclass transformers. *The indicated losses in the table for CRGO as per IS: 1180 (Part-1) 2014 Ammended up to date.*

| Rating (KVA) | Impedance (Percentage) | Max. total losses in watts up to 11 kV Class, Level- 1 (Star-1) | |
|--------------|------------------------|--|-------------|
| | | At 50% Load | At100% Load |
| 16 | 4.5 | 135 | 440 |
| 25 | 4.5 | 190 | 635 |

Note - For 22 KV voltage Class Transformers the permissible total loss values shall not exceed by 5 % of the Maximum total loss values mentioned in above table. (IS 1180 - Part-1 2014 Clause No 6.8 Sub Clause 6.8.1.2)

Tolerances:

No positive tolerance shall be allowed on the maximum total losses given in the above table for both 50% & 100% loading values. In case the actual loss values exceed the above guaranteed values, the transformers shall be rejected at the risk, cost and responsibility of the supplier. The bidder should guarantee individual No load losses.

The values guaranteed in G.T.P. for flux density, no load current at rated voltage, no load current at 100 % & 112.5% of rated voltage and no load loss at rated voltage shall be individually met.

The tolerance on electrical performance excluding total losses at 50% of rated load & total losses at 100% of rated load shall be as given in IS 2026(Part 1).

6.4 Insulation material and clearances:

Materials –

Makes of Electrical grade insulating Kraft paper, Press Board, Perma wood/ Haldi wood insulation shall be declared in GTP by the bidder. The test reports for all properties as per relevant IS amended up to date shall be submitted during inspection .Compliance to Kraft paper IS 9335 [Cl.No.9.1(d) of IS 1180 (Part 1):2014] and for press board IS 1576 [Cl.No.9.1(e) of IS 1180 (Part 1):2014] and rubber gasket shall be ensured through test certificate of the supplier.

- i. The electrical clearance between the winding and body of the tank (between inside surface of the tank and outside edge of the windings) should not be less than 30 mm for 11kV & 40mm for 22kV.
- ii Radial clearances of LV coil (bare conductor) to cores hall be minimum 3.5 mm for 11kV & 4mm for 22kV
- iii Radial clearance between HV & LV winding shall be minimum 11mm for 11kV & 14mm for 22kV
- iv Phase to Phase clearance between HV conductor shall be minimum 10mm for 11kV & 15mm for 22kV
- v Minimum End insulation to Earth shall be 11kV - 25 mm & 22kV- 40mm
- vi Minimum external clearances between bushing terminals



TECHNICAL SPECIFICATION OF 16 AND 25kVA, 11/0.433 kV & 22/ 0.433 kV LEVEL-1 THREE PHASE, NON SEALED TYPE DISTRIBUTION TRANSFORMERS OUTDOOR TYPE OIL IMMERSED WITHOUT CSP FEATURE.

| Voltage Level | Details | 11 kV | 22kV |
|---------------|----------|--------|--------|
| HV | Ph to Ph | 255 mm | 330 mm |
| | Ph to E | 140 mm | 230 mm |
| LV | Ph-to-Ph | 75 mm. | 75 mm |
| | Ph to E | 40 mm. | 40 mm |

6.5 Impedance Value–

The percentage impedance at 75°C. for different ratings shall be as per clause no 6.3 table above.

6.6 Tank

6.6.1 The transformer tank shall be made up of prime quality M.S. sheets of rectangular shape. No other shape will be accepted. The transformer tank shall be of robust construction. All joints of tank and fittings should be oil tight and no bulging shall occur during service. The tank design shall be such that the core and windings can be lifted freely. The tank plates shall be of such strength that the complete transformer when filled with oil may be lifted bodily by means of the lifting lugs provided. Tank inside shall be painted by varnish or oil resistant paint. Top cover plate shall be slightly sloping; approximately 5 to 10 deg. Opposite to LV bushing and edges of cover plate should be bent downwards so as to avoid entry of water through the cover plate gasket. The width of bend plate shall be 25 mm min. The top cover shall have no cut at point of lifting lug. The rectangular tank shall be fabricated by welding at corners.

6.6.2 The transformer tank of corrugation is also acceptable; however shape of tank shall be rectangular only. The corrugation sheets thickness shall be of minimum 1.6mm. Corrugation panel shall be used for cooling. The transformer shall be capable of giving continuous rated output without exceeding the specified temperature rise. Bidder shall submit the detailed calculation sheet along with offer. The safe guard angle frame 25X25X5 mm shall be welded for corrugated side to the tank.

6.6.3 In rectangular shape tanks, horizontal or vertical joints in tank side walls and its bottom or top cover will be not allowed.

Sidewall thickness: 3.15 mm.(min.)

Top and bottom plate thickness: 5 mm.(min)

a) The permanent deflection off plates after pressure/vacuum has been released shall not exceed the values given below.(All figures in mm)



TECHNICAL SPECIFICATION OF 16 AND 25kVA, 11/0.433 kV & 22/ 0.433 kV LEVEL-1 THREE PHASE, NON SEALED TYPE DISTRIBUTION TRANSFORMERS OUTDOOR TYPE OIL IMMERSSED WITHOUT CSP FEATURE.

| Horizontal length of flat Plate | Permanent deflection |
|---------------------------------|----------------------|
| Up to and including 750 mm | 5.0 mm |
| 751 to 1250 mm | 6.5 mm |

- 6.6.4 Reinforced by welded angle 25X25X5 MM on all the outside walls on the edge of tank to form two equal compartments.
- 6.6.5 When transformer tank without oil is subject to air pressure of 80 KPa above atmospheric pressure for 30 min as per IS 1180 (Part 1):2014. Pressure test shall be performed carefully as per IS 1180 (Part 1):2014 Clause no.21.5.1 at the time of 1st stage inspection only to confirm the adequacy of reinforcement angle and gauge of the tank and certified by E.E. (IW).
- 6.6.6 All welding operations to be carried out by MIG process.(Metal Inert Gas Welding)
- 6.6.7 Lifting lugs: 2 nos. welded heavy duty lifting lugs of MS plate of 8 mm (minimum) thickness suitably reinforced by vertical supporting flat of same thickness as of lug welded edgewise below the top cover on the side wall. They shall be so extended that cutting of bend plate is not required. 2 nos. of welded heavy duty lifting lugs of MS plate of 8 mm thickness should be on the top plate of transformers.
- 6.6.8 Pulling lugs: 2 nos. of welded heavy duty pulling lugs of MS plate of 8mm thickness shall be provided to pull the transformer horizontally.
- 6.6.9 All bolts / nuts / washers exposed to atmosphere shall be as follows:[Clause no.15.3 of IS 1180 (Part 1):2014]
- a) Size 12mm or below—stainless steel.
 - b) Above 12mm--- steel with suitable finish like electro galvanizedwith passivation or hot dip galvanized.
- 6.6.10 Top cover fixing bolts: GI nut bolts of 1/2" diameter (min) with one plain washer shall be used for top cover fixing, spaced at 4" apart. 6 mm neoprene bonded cork oil resistance gaskets conforming to type B/C IS 4253 Part-II amended up to date will be placed between tank and cover plate.
- 6.6.11 Vertical clearance: - The height of the tank shall be such that minimum vertical clearance up to the top cover plate of 120 mm is achieved from top yoke.
- 6.6.12 The transformer tank shall be of adequate mechanical strength to withstand positive and negative pressures built up inside the tank while the transformer is in operation.
- 6.6.13 The tank design shall be such that the core and windings can be lifted freely.
- 6.6.14 Plain tank shall be capable of withstanding a pressure of 80kPa for 30 minutes and a vacuum of 250 mm of mercury for 30 minutes (Type Test). The permanent deflection of flat plates shall not exceed the values given in IS 1180(Part 1): 2014 clauseno. 21.5.1.1.



**TECHNICAL SPECIFICATION OF 16 AND 25kVA, 11/0.433 kV & 22/ 0.433 kV LEVEL-1 THREE PHASE,
NON SEALED TYPE DISTRIBUTION TRANSFORMERS OUTDOOR TYPE OIL IMMERSED WITHOUT CSP
FEATURE.**

- 6.6.15 Thermometer pocket must be located at center of top cover or high side of tank height for true value of maximum top oil temperature.
- 6.6.16 The construction of the tank should be only non-sealed.
- 6.6.17 QR code laminated P touch labels shall be fixed on transformer tank body below the name plate depicting various technical details such as Name of manufacturer, rating, Serial no, date of manufacturing, A/T No. etc.

6.7 Off Load Taps:

6.7.1 No taps are required for 16kVA & 25kVA Transformers.

7.0 Efficiency:

The efficiency is the ratio of output in KW to the input in KW.

$$\text{Efficiency} = \frac{(\text{Input in KW} - \text{Total Losses in KW})}{\text{Input in KW}}$$

8.0 Heat Dissipation:

- a) Heat Dissipation by tank walls excluding top and bottom plates should be 500Watts/Sq. meter.
- b) Heat dissipation calculation should be based on maximum measured total loss i.e. (No load loss at rated excitation + load loss at 100% Loading converted to 75 deg C reference temperature) shall be supplied during temperature rise test.
- c) The heat dissipation by tank wall should be increased to appropriate value considering the climatic temperature rise. If required, the radiators shall be provided as following d and e clause:
- d) Only fins type radiators 1.25 mm thick shall be used. The tender should submit the heat dissipation calculations with the offer.
- e) 2nos of radiators shall be provided on HV side and should be fixed at right angle to the sides and not diagonally. The size of radiators shall cover at least 50% of the bottom yoke, full core and top yoke

9.0 Total Minimum Oil Volume:

The firm should maintain the minimum oil volume in all supplied transformers as mentioned below or oil up to mark indicator level whichever is more.



TECHNICAL SPECIFICATION OF 16 AND 25kVA, 11/0.433 kV & 22/ 0.433 kV LEVEL-1 THREE PHASE, NON SEALED TYPE DISTRIBUTION TRANSFORMERS OUTDOOR TYPE OIL IMMersed WITHOUT CSP FEATURE.

| Sr.No. | KVA rating | Oil in liters | (exclusive of oil absorbed in core & coil assembly) |
|--------|------------|---------------------------|---|
| | | Voltage rating11/0.433 kV | Voltage rating22/0.433 kV |
| 1 | 16 | 50 | 70 |
| 2 | 25 | 70 | 100 |

Note:

Transformer shall be supplied complete with first filling of oil up to minimum position corresponding to the operating temperature of 30°C (for sealed type transformers) on oil indicator fixed on side wall of the tank and Transformer shall be supplied complete with first filling of oil up to the mark indicator level of conservator(for non-sealed type transformer). Detailed calculation of absorption should be submitted.

10.0 Conservator: (Non Sealed Type Transformer)

- a. The total volume of conservator shall be such as to contain 10% of total quantity of oil. Normally 3% quantity of the total oil will be contained in the conservator. Dimension of the conservator shall be indicated on the General Arrangement Drawing. The capacity of the conservator tank shall be designed keeping in view the total quantity of oil and its contraction and expansion due to the temperature variations.
- b. Oil level indicator shall be provided on the side which will be with fully covered detachable flange with single gasket and tightened with MS nut-bolt. Level indication by color shall not be accepted.
- c. The inside diameter of the pipe connecting the conservator to the main tank should be 25 to 50 mm and it should be project into the conservator in such way that its end is approximately 20 mm above the bottom of the conservator so as to create a sump for collection of impurities. The minimum oil level (corresponding to (-) 5 deg.) should be above the sump level. [Refer Cl.no.16.3 of IS 1180 (Part1):2014]
- d. There shall be minimum -5deg, normal 30deg and maximum 98deg marking on the oil gauge indicator of the conservator.

11.0 Breather: (Non Sealed Type Transformer)

- a. The material used for breather shall be only of Poly propylene.
- b. The dehydrating agent shall be silica gel. The volume of breather shall be suitable for 250 gm to 16 & 25 kVA silica gel conforming to IS 3401. Makes of the breather shall be subject to purchaser's approval. The make and design of breather shall be subject to approval of CE (Testing & QC).

12.0 Terminals:

- a. On H.V. side the bimetallic connector to be provided with bimetallic lug of suitable rating.



**TECHNICAL SPECIFICATION OF 16 AND 25kVA, 11/0.433 kV & 22/ 0.433 kV LEVEL-1 THREE PHASE,
NON SEALED TYPE DISTRIBUTION TRANSFORMERS OUTDOOR TYPE OIL IMMERSSED WITHOUT CSP
FEATURE.**

- b. The rating of brass rod for H.V. & L.V. shall be as per relevant IS for different capacity of Transformer. [Following (d) and (e) are indicative and shall be conformed with relevant IS]]
 - c. Brass rods of 12 mm. diameter for HT with necessary nuts, check-nuts and plain thick tinned washer.
 - d. Tinned copper Rod of 12 mm diameter with LT extension with suitable cable lugs, necessary nuts, check-nuts and plain thick tinned washer.
- 13.0 Bushings &Connections:**
- 13.1 The transformers shall be fitted on high voltage and low voltage sides with outdoor type bushings of appropriate voltage and current ratings. The high voltage bushings (3nos.) shall be provided with R-Y-B colour coding marking & shall conform to IEC 60137. The low voltage bushings (4 nos.) shall conform to IS 3347 & IS 7421. Alternatively, the low voltage side may be made suitable for adoption of XLPE cables of suitable size. The dimensions shall conform to IS 1180(Part 1): 2014 clause no. 10.1.5.
 - 13.2 The bushing shall be made in two parts. The outer bushing shall be of porcelain. The dimensions of the outer bushing shall confirm to the relevant Part/Section of IS 3347 depending on the voltage class. The internal bushing shall be of either porcelain or tough insulating material, like epoxy and shall have embedded stem. Metal portion of the internal HV and LV bushing inside the tank shall remain dipped in oil in all operating conditions. [Refer Cl.no.10.1.3 of IS 1180 (Part1):2014]
 - 13.3 Gaskets shall be made of synthetic rubber or synthetic rubberized cork resistant to hot transformer oil or Nitrile Rubber. [Refer Cl.no.10.1.4 of IS 1180 (Part1):2014]
 - 13.4 The dimensions of the bushings of voltage classes shall confirm to Cl. no 10.1.5 of IS 1180 (Part1):2014.
 - 13.5 For 11 kV class 12 kV bushing shall be used and for 433 volts 1.0 kV bushing shall be used. Bushings of the same voltage class shall be interchangeable. Bushings with plain shed shall be as per relevant IS:3347 amended up to date & IEC 60137. HV bushings shall be mounted on the top of the transformer tank & LV bushings shall be mounted on side of the transformer tank.
 - 13.6 HV bushings shall be mounted on curvature shaped embossed plate and not on welded MS ring. Supporting clamps for LT cable should be provided to avoid the weight of cable on the Bushing.
 - 13.7 The minimum creepage distance for both HV & LV Bushings shall not be less than 25 mm per kV.
 - 13.8 Compliance of bushing as per IEC 60137/ IS 7421 and relevant part of IS 3347 shall be ensured through test certificate from the supplier of transformer manufacturer firm getting the same tested from BIS recognized/ group 2 category of laboratory.
 - 13.9 Supporting clamp for Cable should be provided to avoid weight of cable on the bushing/bushing rod.



**TECHNICAL SPECIFICATION OF 16 AND 25kVA, 11/0.433 kV & 22/ 0.433 kV LEVEL-1 THREE PHASE,
NON SEALED TYPE DISTRIBUTION TRANSFORMERS OUTDOOR TYPE OIL IMMERSED WITHOUT CSP
FEATURE.**

14.0 Internal connections:

14.1 H.V. Winding:

- (i) In case of H.V. winding all jumpers from winding to bushing shall have cross section larger than winding conductor.
- (ii) Inter coil connection shall be by crimping and brazing.
- (iii) In case of Aluminum Winding Delta joints shall be with crimping and brazing only.
- (iv) Lead from delta joint shall be connected to bushing rod by brazing only.

14.2 L.V. Winding:

- (i) For Aluminum windings inter coil connections crimping & silver brazing shall be used.
- (ii) L.T. Star point shall be formed of Aluminum flat of sufficient length. Lead from winding shall be connected to the flat by crimping and brazing.
- (iii) Firm connections of L.T. winding to bushing shall be made of adequate size of 'L' shaped flat. Connection of L.T. Coil lead to 'L' shape flat shall be by crimping and brazing. Alternatively 'L' shape lug of adequate capacity effectively crimped shall be acceptable.
- (iv) 'L' shape flat/lug shall be clamped to L.V. Bushing metal part by using nut, lock-nut and washers.

15.0 Tank base channel / Mounting Arrangement:

The under-base of the transformer shall be provided as per clause 14.1 of IS 1180(Part1):2014

16.0 Terminal Marking Plates and Rating Plates :

- (a) All Transformer HV terminals shall be provided terminal marking plated to Tank. Each terminal, including with neutral, shall be distinctly marked on both primary & secondary in accordance with the connection diagram fixed which shall conformed to latest IS-2026 (part-IV) upon the transformer
- (b) Each Transformer shall be provided with Rating plate having marking as per IS 1180 (part-1):2014 clause no 13 clearly indicating max. total losses at 50% rated load in watts and maximum total losses at 100% rated load in watts.
- (c) Rating & terminal marking plates shall be combined into one plate and shall be mark with standard mark Govern by the provisions of the BIS act 1986.
- (d) Terminals shall be provided with terminal marking plates. The transformer shall be provided with riveted rating plate of minimum 18 SWG aluminum anodized material sheet in a visible position. The entries of the rating plate shall be in indelibly marked (i.e. by etching, engraving or stamping).
- (e) Marking as 'M.S.E.D.C.L' and 'Sr. No.' of transformer shall be engraved on transformer main tank below L.T. bushings.
- (f) The name of the company, order No., capacity, month and year of manufacturing shall be engraved on separate plate which shall be firmly welded to main tank and shall form integral



**TECHNICAL SPECIFICATION OF 16 AND 25kVA, 11/0.433 kV & 22/ 0.433 kV LEVEL-1 THREE PHASE,
NON SEALED TYPE DISTRIBUTION TRANSFORMERS OUTDOOR TYPE OIL IMMERSED WITHOUT CSP
FEATURE.**

part of the tank.

- (g) The distribution transformer shall be marked with the Standard Mark. The use of Standard Mark is governed by the provisions of the Bureau of Indian Standards Act, 1986 and the Rules Regulations made thereunder.
- (h) In addition to the BIS certification mark license No. (a seven digit number) represented as CM/L xxxxxxx shall be clearly & indelibly marked on the rating plate as per the norms of BIS. The width to height ratio of ISI symbol shall be 4:3.
- (i) The copy of valid ISI license shall be submitted in support with the bidding document.
- (j) Each transformer shall be provided with rating plate having marking as per Cl.no.13 of IS 1180(Part 1): 2014 clearly indicating maximum total losses at 50% rated load in watts and maximum total losses at 100% rated load in watts.
- (k) Following details shall also be given on the rating plate as per Fig.1 of Cl.no.13.1 of IS 1180(Part 1): 2014 and terminal marking plate with diagram shall be in accordance with Cl.no.13.2 of IS 1180(Part 1): 2014.
 - (i) ISI Mark.
 - (ii) Energy Efficiency level as approved by BIS
 - (iii) Order No. – Month & year.
 - (iv) Sr.No. of transformer.
 - (v) Date of manufacturing – Month & year.
 - (vi) Date of expiry of guarantee period – month & year. (vii)Maximum guaranteed 50% load loss & 100 % load loss figures.
 - (viii) Name and full address of the manufacturer.
 - (ix) Capacity.
 - (x) Rating.

(All details on the rating and diagram plate shall be indelibly marked i.e. by engraving or stamping or etching).

17.0 Fittings:

The following standard fittings shall be provided

| | | |
|---|-----------------------------------|--|
| 1 | Rating and terminal marking plate | 1 no. |
| 2 | Earthing terminals with lugs. | 2 nos. |
| 3 | Lifting lugs | 4 nos. (2 nos. for tank and 2 nos. for top plate of the transformer) |



**TECHNICAL SPECIFICATION OF 16 AND 25kVA, 11/0.433 kV & 22/ 0.433 kV LEVEL-1 THREE PHASE,
NON SEALED TYPE DISTRIBUTION TRANSFORMERS OUTDOOR TYPE OIL IMMERSSED WITHOUT CSP
FEATURE.**

| | | |
|----|--|---|
| 4 | Pulling lugs | 2 nos |
| 5 | Drain valve - 32mm for all Transformers (It shall be covered with metallic box spot welded to tank) IS554 | 1 No. |
| 6 | Silica gel breather 250gms capacity | 1No. |
| 7 | Oil filling hole with cap (On Conservator) | 1No. |
| 8 | Conservator with drain plug | 1No. |
| 9 | The pipe connecting the conservator to the main tank | 1No. |
| 10 | Thermometer pocket with cap | 1No. |
| 11 | Oil filling hole with cap on top cover | 1No. |
| 12 | Air release device (for non- sealed transformer) | 1No. 1No. |
| 13 | Oil level gauge indicating oil level at minimum, 30°C and maximum operating temperature; or on conservator with 3 position shall be provided Minimum (-) 5 deg.C. Normal 30deg.C, Maximum 98 deg.C. | 1No. |
| 14 | HT & LT bushing and terminal connectors | 3 nos. of HT bushing and 4 nos. of LT bushings shall be provided with 3 nos. of brass nuts and 2 plain brass washers. |
| 15 | Lightening Arrestors for HT bushings | 3 Nos. |
| 16 | Years Guarantee plate | 1 No. |
| 17 | Anti-theft stainless steel fasteners with breakaway nut at top cover | 4 Nos. |

Any other fitting necessary for satisfactory performance. The fittings shall be provided in accordance with Cl no. 20.1 (a to v) & Cl no. 20.2 Optional fittings of IS 1180 (Part1):2014 (if required).



TECHNICAL SPECIFICATION OF 16 AND 25kVA, 11/0.433 kV & 22/ 0.433 kV LEVEL-1 THREE PHASE, NON SEALED TYPE DISTRIBUTION TRANSFORMERS OUTDOOR TYPE OIL IMMERSSED WITHOUT CSP FEATURE.

17.0 Fasteners.

1. All bolts, studs, screw threads, pipe threads, bolt heads and nuts shall comply with the appropriate Indian standards for metric threads or the technical equivalent.
2. Bolts or studs shall not be less than 6 mm in diameter except when used for small wiring terminals.
3. All nuts and pins shall be adequately locked.
4. Wherever possible bolts shall be fitted in such manner that in the event of failure of locking resulting in the nuts working loose and falling off, the bolt will remain in position.
5. All ferrous bolts, nuts and washers placed in outdoor positions shall be treated to prevent corrosion by hot dip galvanizing except high tensile steel bolts and spring washers, which shall be Electro, galvanized. Appropriate precautions shall be taken to prevent electrolytic action between dissimilar materials.
6. Each bolt or stud shall project at least one thread but not more than three threads through the nut, except when otherwise approved for terminal board studs or relay stems. If bolts are provided at inaccessible places for ordinary spanners, special spanners shall be provided.
7. The length of screwed portion of the bolts shall be such that no screw thread may form part of a sheer plane between members.
8. Taper washers may be provided where necessary. Protective washers of suitable material shall be provided front and back of the securing screws.
9. LT side should be of Pad type terminal.

18.0 Lightning Arrestors:

The Lightning Arrestors (Disconnecter type) of high surge capacity of 9 kV (Vrms), 5 kA (8/20 micro wave shape) for 11 kV class transformers and 18 kV (Vrms), 9kA (8/20 micro wave shape) conforming to IS: 3070/1993 shall be mounted on the HV bushings of transformer, clamped securely to the tank, to protect the transformer and associated line equipment from the occasional high voltage surges resulting from lightning or switching operations. The earthing terminal of the lightning arresters shall be grounded separately.

Random sample of LA shall be destructively tested by breaking the LA to confirm availability of inside component only.

19.0 Transformer Oil

Transformer oil to be used in all the Distribution transformers shall comply with the requirements of latest IS 335/2018 amended up to date thereof. The Unused Mineral Insulating Oils (type II)are obtained by distillation and refining of crude petroleum as required to meet the properties specified below.



**TECHNICAL SPECIFICATION OF 16 AND 25kVA, 11/0.433 kV & 22/ 0.433 kV LEVEL-1 THREE PHASE,
NON SEALED TYPE DISTRIBUTION TRANSFORMERS OUTDOOR TYPE OIL IMMERSSED WITHOUT CSP
FEATURE.**

| Sr. No. | Property | Test Method | Permissible Values |
|--|--|--|---|
| A. Function | | | |
| 1. | Viscosity at 40°C | IS : 1448 (Part 25) | 15 mm ² /s, Max. |
| 2. | Viscosity at 0°C | IS : 1448 (Part 25) | 1800 mm ² /s, Max. |
| 3. | Pour – Point | IS : 1448 (Part 10/Sec2) | - 10°C, Max. , to be based on LCSET |
| 4. | Water content | IEC 60814 | 30 mg/kg , Max. / 40 mg/kg, Max. |
| 5. | Breakdown voltage | IS : 6792 | 30kV / 70kV, Min. |
| 6. | Density at 20°C | IS : 1448 (Part 16) | 0.895 g / ml. Max. |
| 7. | DDF at 90°C | IS : 16086 | 0.005, Max. |
| 8. | Particle content | IS : 13236 | No general requirement. |
| B. Refining / stability | | | |
| 9. | Appearance | ---- | Clear, free from sediment and suspended matter. |
| 10. | Acidity | IEC 62021-1 | 0.01 mg.KOH / g, Max. |
| 11. | Interfacial tension | ASTM D 971 | No general requirement. |
| 12. | Total sulphur content | ISO 14596 or 4294 ASTM D | No general requirement. |
| 13. | Corrosive sulphur | DIN 51353 | Not corrosive. |
| 14. | Potentially corrosive sulphur | IS : 16310 | Not corrosive. |
| 15. | DBDS | IS : 16497 (Part 1) | Not detectable (<5mg/kg) |
| 16. | Inhibitors according to IS : 13631 / IEC : 60666 | IS : 13631 | (U) Uninhibited oil: not detectable (<0.01%) |
| | | | (T) Trace inhibited oil : <0.08% |
| | | | (I) Inhibited oils : 0.08%-0.40% |
| 17. | Metal passivator additives according to IS : 13631 / IEC : 60666 | IS : 13631 | Not detectable (<5mg/kg) |
| 18. | Other additives | --- | See 7 |
| 19. | 2-Furfural and related compounds content | IS : 15668 | Not detectable (<5mg/kg) For each individual compound. |
| C. Performance | | | |
| 20. | Oxidation stability | IS : 15668(Method C) (U) Uninhibited oil : 164h (T) Trace inhibited oil :332h (I) Inhibited oil :500h | For oils with other antioxidant additives and metal passivator. |
| a) | • Total acidity,9 | 1.9.4 of IS : 12422 | 1.2mg KOH/g, Max. |
| b) | • Sludge,9 | 1.9.1 of IS : 12422 | 0.8%, Max. |
| c) | • DDF at 90°C. 9 | 1.9.6 of IS : 12422 | 0.500, Max |
| 21. | Gassing tendency | IEC : 60628, Method A | No general requirement. |
| 22. | ECT | -- | No general requirement. |
| D. Health, Safety and Environment (HSE) | | | |
| 23. | Flash point | IS : 1448 (Part 21) | 135°C, Min. |
| 24. | PCA content | IP : 346 | 3%, Max. |



**TECHNICAL SPECIFICATION OF 16 AND 25kVA, 11/0.433 kV & 22/ 0.433 kV LEVEL-1 THREE PHASE,
NON SEALED TYPE DISTRIBUTION TRANSFORMERS OUTDOOR TYPE OIL IMMERSED WITHOUT CSP
FEATURE.**

| | | | |
|-----|-------------|------------|------------------------------|
| 25. | PCB content | IS : 16082 | Not detectable (<2mg/kg) |
|-----|-------------|------------|------------------------------|

Refer Note to table no. 2 of IS: 335; 2018

20.0 Test and Inspection:-

All routine, type and special tests as described in Clause 21.2 to 21.4 of IS 1180 (Part 1):2014 shall be performed as per relevant parts of IS 2026. Pressure and oil leakage test shall be conducted as per Clause 21.5 of IS 1180 (Part1):2014.

20.1 Routine Tests:

The following shall constitute the Routine tests:

- a) Measurement of winding resistance [IS 2026 (Part 1)].
- b) Measurement of voltage ratio and check of phase displacement [IS 2026(Part1)].
- c) Measurement of short circuit impedance and load loss at 50 percent and 100 percent load [IS 2026 (Part 1)].
- d) Measurement of no load loss and current [IS 2026 (Part 1)].
- e) Measurement of insulation resistance [IS 2026 (Part 1)].
- f) Induced over-voltage withstand test [IS 2026 (Part 3)].
- g) Separate-source voltage withstand test [IS 2026 (Part 3)].
- h) Pressure test
- i) Oil leakage test

20.2 Type Tests (to be conducted on one unit):- The following shall constitute the type tests:

- a) Lightning impulse test [IS 2026 (Part 3)].
- b) Temperature-rise test [IS 2026 (Part 2)].
- c) Short-circuit withstand test [IS 2026 (Part 5)].
- d) Pressure test.

Note – Minimum total loss (No load + load loss at 75 deg' C reference temperature) at 100 % loading shall be supplied during temperature rise test.

In addition to that the successful bidder shall submit the type test report of transformer Oil & HV/LV bushings as per relevant IS with offer

- 20.3 The Type Tests as per Clause 20.2 above shall be successfully carried out at laboratories accredited by National Accreditation Board for Testing and Calibration Laboratories (NABL) in accordance with IS 1180(Part 1):2014 as amended from time to time and technical specifications, within the last 5 (five) years prior to the date of offer.
- 20.4 The type test reports should be submitted and got approved from the Chief Engineer (Testing & QC) before commencement of supply.
- 20.5 Special Tests (to be conducted on one unit):- The following shall constitute the special tests.
 - a) Determination of sound levels [IS 2026 (Part 10)].



**TECHNICAL SPECIFICATION OF 16 AND 25kVA, 11/0.433 kV & 22/ 0.433 kV LEVEL-1 THREE PHASE,
NON SEALED TYPE DISTRIBUTION TRANSFORMERS OUTDOOR TYPE OIL IMMERSSED WITHOUT CSP
FEATURE.**

- b) No load current 112.5 percent voltage [refer clause 7.9.2 of IS 1180(Part 1):2014].
- c) Paint adhesion tests: The test is performed as per ASTM D 3359 (Standard Test Methods for measuring adhesion by Tape Test).
- d) BDV and moisture content of oil in the transformer (IS 335). Note: Tests at (c) and (d) may be carried out on more than one unit.

20.6 Pressure and Oil leakage Test

20.6.1 Pressure Test (Type Test)

The transformer tank subjected to air pressure of 80 kPa for 30 min and vacuum of 250 mm of mercury for 30 min. The permanent deflection of flat plate, after pressure/vacuum has been released, shall not exceed the values given below.

| Length of Plate | Deflection |
|-------------------|------------|
| Up to 750mm | 5.0 mm |
| 751 mm to 1250 mm | 6.5 mm |

20.6.2 Pressure Test (Routine Test):

a) Plain tanks:

The transformer tank with welded / bolted cover shall be tested at a pressure of 35 kPa above atmospheric pressure maintained inside the tank for 10 min. There should be no leakage at any point.

b) Corrugated tanks:

The corrugated transformer tank shall be tested for air pressure of 15 kPa above atmospheric pressure maintained inside the tank for 10 min. There should be no leakage at any point.

20.6.3 Oil leakage Test (routine Test):

The assembled transformer for sealed/ non-sealed type with all fittings including bushing in position shall be tested at a pressure equivalent to twice the normal head measured at the base of the tank for 8 h. There should be no leakage at any point. Tank with corrugations shall be tested for oil leakage test a pressure of 15 kPa measured at the top of the tank for 6 h. There should be no leakage at any point.

21.0 Challenge Testing:

- 21.1 The manufacturer can also request challenge testing for any test based on specification and losses.
- 21.2 The challenger would request for testing with testing fees. The challenge test fees are proposed at least three times the cost of testing. This is likely to deter unnecessary challenges.
- 21.3 The challenger would have the opportunity to select the sample from the store and any such challenge should be made within the guarantee period. The party challenged, challenger and the utility could witness the challenge testing.



**TECHNICAL SPECIFICATION OF 16 AND 25kVA, 11/0.433 kV & 22/ 0.433 kV LEVEL-1 THREE PHASE,
NON SEALED TYPE DISTRIBUTION TRANSFORMERS OUTDOOR TYPE OIL IMMERSSED WITHOUT CSP
FEATURE.**

- 21.4 The challenge testing would cover following tests:
1. Measurement of magnetizing current.
 2. No load losses test.
 3. Load losses test (at 50 % loading or as per routine test).
 4. Temperature rise test.
- 21.5 The challenge test could be conducted at NABL Laboratory, like ERDA and CPRI.
- 21.6 If the values are within the limits, the products gets conformed.
- 21.7 No positive tolerances in losses are permitted.
- 21.8 If the product is not conformed, the manufacturer would pay the challenge fee and challenger would get the fee refunded. However as a redress system the challenger would be allow to ask for fresh testing of two or more samples from the store and the same be tested in NABL Laboratory in presence of party challenge, challenger and the utility.
- 21.9 If any one of the above sample does not conform the test, then the product is said to have failed the test. In such cases the manufacturer will be declared as unsuccessful manufacturer for the said product with wide publicity and would not be allowed to compete in tenders of the MSEDCL for the period of three years and heavy penalty would be imposed.
- 22.0 Type Test report submission:-**
- 22.1 In respect of the successful bidder, the purchaser reserves the right to demand repetition of some or all the type tests in presence of the purchaser's representative.
- In case the unit fails in the type tests, the complete supply shall be rejected. The bidders are therefore requested to quote unit rates for carrying out each type test, which however, will not be considered for evaluation of the offer.
- 23.0 Drawings & Calculation sheet:-**
- 23.1 Following drawings shall be uploaded by the bidder duly sealed & signed if bidder does not agree to supply the transformers as per MSEDCL standard drawings as given in standard GTP attached with this specification Rating & Diagram Plate Drawing.(As per Cl.no.13.1 Fig.1 of IS 1180(Part1):2014
- i. General Arrangement Drawing.
 - ii. Internal Construction Drawing
 - iii. Core Assembly drawing
 - iv. HV& LV Bushings Assembly drawing
 - v. Creepage distances distance drawing of HV&LV Bushing
 - vi. Silica gel breather drawings
 - vii. BEE certification
 - viii. Calculation sheet for flux density and total losses at 50% and 100% loading
 - ix. Heat dissipation calculations
 - x. Oil absorption calculations
- 23.2 The drawings shall be of A-3 (420 x 297 mm) size only. The bidder should also supply along with offer the pamphlets/literatures etc. for fittings/accessories.



TECHNICAL SPECIFICATION OF 16 AND 25kVA, 11/0.433 kV & 22/ 0.433 kV LEVEL-1 THREE PHASE, NON SEALED TYPE DISTRIBUTION TRANSFORMERS OUTDOOR TYPE OIL IMMERSSED WITHOUT CSP FEATURE.

- 233 The bidder should not change design once offered as per A/T, approved drawings and Type Test Reports.
- 234 The successful Bidders shall submit complete a set of legible and clear drawings (as listed in Cl.No.23.1) of the transformer to CE (Testing & QC) for approval before offering first factory inspection of the transformers.

24.0 Rejection :-

- 24.1 Apart from rejection due to failure of the transformer to meet the specified test requirements the transformer shall be liable for rejection on any one of the following reasons.
- i. Maximum total losses at 50 % load & 100% Load losses exceeds the specified values mentioned in Cl.No.6.3 above.
 - ii. Impedance voltage value exceeds he guaranteed value plus tolerances as mentioned at Cl.No.6.5 above.
 - iii. Type test are not carried out as per clause no. 20.2 & 20.3 of the specification.
 - iv. Drawings are not submitted as per clause no. 23.0 of the specification.
 - v. GTP not submitted as per clause no. 26.0 of the specification.
 - vi. Heat dissipation calculation sheet are not submitted as per .clause no.8.0 of the specification

25.0 Cleaning and Painting.

- i. The external surface of transformers shall be painted with one coat of Epoxy primer (30 micron) and two coats of Polyurethane (finish coat) Liquid paint (each 25 micron) and inside surface of the tank hot oil resistant paint/ varnish with one coat with dry film thickness as mentioned in Table 12 , Cl.no.15.5 of IS 1180(Part 1):2014.
- ii. The test of measurement of paint thickness shall be carried out cross hatch test, chemical test and other as per IS 13871:1993
- iii. The month and year of supply shall be painted in red bold **Marathi** lettering at two places one at conservator and other at sum conspicuous place on the transformer which shall be clearly visible from the ground.

26.0 Standard Guaranteed & Technical Particulars:

The specific requirement of MSEDCL is given in GTP attached with this specification, the bidder if agreed to all technical parameters given as listed in GTP the statement such as “as per MSEDCL’s requirement” shall be considered and if he is wants offer deviations to specific requirement they can offer their technical parameters in column given in GTP. The GTP should be filled otherwise offer shall liable for rejection.

27.0 Testing facility:

The bidder should have adequate testing facility for all routine and acceptance tests and
Tech Spec. No. CE/T-QC/MSD/DTC dtd.17.02.2021 revised on 01.04.2022 Page 22 of 66



**TECHNICAL SPECIFICATION OF 16 AND 25kVA, 11/0.433 kV & 22/ 0.433 kV LEVEL-1 THREE PHASE,
NON SEALED TYPE DISTRIBUTION TRANSFORMERS OUTDOOR TYPE OIL IMMERSED WITHOUT CSP
FEATURE.**

also arrangement for measurement of losses, resistance, etc. details of which will be enumerated in the tender.

28.0 Submission Routine Test Certificate:

- a. The successful bidder shall submit the routine test certificate along with documentary evidence for having paid the Excise Duty for the following raw materials viz. Oil, Aluminum, copper for conductors, insulating materials, core materials, bushings at the time of routine testing of the fully assembled transformer
- b. Instruction and operation Manual: The successful bidder shall be required to submit 5 copies of instruction and Operation manual for each lot of 100 Transformers (or part thereof) supplied. This instruction manual should give complete details about the pre-commissioning tests/checks and the details of preventive maintenance etc.

29.0 Stage Inspection:

1. After receipt of LoA, Supplier shall give 15 days' advance intimation to the Chief Engineer (MMD) to organize stage inspection.
2. After receipt of intimation from successful bidder, Chief Engineer (MMD) will depute MSEDCL's representative to visit factory of bidder for Stage Inspection.
3. Activities below will be carried out during Stage Inspection:
 - (a) Verification of available raw material stock & its quality.
 - (b) Verification of assembly of core, windings and other core materials.
 - (c) Verification of Raw materials such as core stamping, winding conductor, oil etc. Bidder shall use these materials manufactured/supplied by the standard manufacturers and furnish the manufacturer's test certificates, proof of purchase from those manufacturers, documentary evidence for having paid the excise duty for the information of the department.
 - (d) Verification of Performance certificate issued by MSEDCL for earlier transformers supplied by bidder and document of compliance done by manufacturer against failure of supplied transformers in previous tenders of MSEDCL, if any.
 - (e) Verification of original type tests reports, Drawings & GTP, if required.
4. After satisfactory inspection, MSEDCL's representative will give clearance to the bidder/manufacturer for further process.
5. MSEDCL's representative may visit factory at any stage of manufacturing process to verify effective use of inspected raw material. The successful bidder shall grant free access to the MSEDCL's representatives at a reasonable time when the work is in progress.

30.0 Final Inspection:

1. After completion of manufacturing process of all quantity (Lot) as per MSEDCL's clearance letter, Supplier shall give intimation to the Chief Engineer (MMD) to organize final inspection.
2. After receipt of intimation from successful bidder, Chief Engineer (MMD) will depute MSEDCL's representative to visit factory of bidder for final Inspection.

Activities below will be carried out during final Inspection:

- (a) Visual inspection of outer side, design, dimensions, color, name plate etc. of all



TECHNICAL SPECIFICATION OF 16 AND 25kVA, 11/0.433 kV & 22/ 0.433 kV LEVEL-1 THREE PHASE, NON SEALED TYPE DISTRIBUTION TRANSFORMERS OUTDOOR TYPE OIL IMMERSED WITHOUT CSP FEATURE.

(100%) ready transformers from offered lot.

- (b) After visual inspection, Inspector will select 10% quantity of transformers at random from offered and visually inspected lot.
- (c) 10 % of the transformers offered will be tested without opening the transformer for all Routine tests as per MSEDCL's technical specifications & related IS. Heat Run Test will have to be carried out on one transformer having maximum total Losses at 100% load.
- (d) Out of balance 90% distribution transformers, one transformer shall be opened and all design technical parameters should be checked as per approved GTP, approved drawings and technical specifications.
- (e) If any technical parameters are found deviating from the approved GTP, approved drawings & technical specifications during final inspection, whole lot shall be reoffered for final inspection after rectification.

3. After satisfactory final inspection, MSEDCL's representative will give clearance to the bidder/manufacturer for dispatch to allotted store.

31.0 Testing of all Distribution Transformers for total losses at 50% load and 100% load at MSEDCL stores:

After receipt of transformers at stores centers, all distribution transformers from the lot will be tested for total Losses at 50% load and 100% load at all stores by MSEDCL as well as by a third party NABL lab like ERDA, etc. Supplier has liberty to be present at the time of testing.

32.0 Random Sample Testing (RST)

- 32.1** The bidder should intimate to Chief Engineer (MMD) of completion of dispatches of whole lot of Distribution Transformers to stores against this tender.
- 32.2** Chief Engineer (MMD), M.S.E.D.C.L will select the stores for Random Sample Testing (RST) and depute Executive Engineer (Testing) to carry out RST of the lot.
- 32.3** Advance intimation of 15 days will be given to supplier for joint inspection.
- 32.4** The date of RST will not be altered to the convenience or request of supplier. If supplier's representative fails to attend on the date fixed for RST, the RST will be carried out in his absence and results of RST will be binding on supplier. In case the selected transformer fails in any of the tests, complete lot of transformers will be rejected.
- 32.5** Activities below will be carried out by EE (Testing) during Random Sample Testing: Visual inspection of design, dimensions, color, name plate, radiator, bushings, LAs, Conservator tank, breather etc. of all (100%) transformers from supplied lot.
- 32.6** EE (Testing) will select one transformer at random from the lot of transformers already tested for total Losses at 50% load and 100% load which shall be opened and all design technical parameters shall check as per approved GTP, approved drawings and technical specifications.
That Selected transformer for random testing shall be tested for all routine testing before opening.
- 32.7** If any technical parameters are found deviating from the approved GTP, approved drawings & technical specifications during Random Sample Testing, whole lot shall be rejected.



**TECHNICAL SPECIFICATION OF 16 AND 25kVA, 11/0.433 kV & 22/ 0.433 kV LEVEL-1 THREE PHASE,
NON SEALED TYPE DISTRIBUTION TRANSFORMERS OUTDOOR TYPE OIL IMMERSSED WITHOUT CSP
FEATURE.**

33.0 Inspection & Testing of Transformer Oil:

The tenderer shall make arrangements for testing of transformer oil as per IS 335/2018 to be used in the transformers and testing will be done in presence of purchaser's representative.

To ascertain the quality of transformer oil, original manufacturer's test report should be furnished to EE (Testing) at the time of factory inspection for acceptance of the lot.

34.0 Quality Assurance

34.1 The bidder shall invariably furnish following information along with the offer failing to which the offer will be rejected.

34.2 Certificates of following materials shall be submitted as per relevant standards indicated in Clause No.9.1 of IS 1180(Part1):2014.

- i. Copper / Aluminum conductor
- ii. Transformer oil
- iii. C.R.G.O.Core.
- iv. Insulating / Kraft paper.
- v. Porcelain Bushings
- vi. Steel Plate used for Tank, press board.

34.3 Names of the supplier for the raw material, list of standard accordingly to which the raw materials are tested, list of test normally carried out on raw materials in presence of bidder's representatives, copies of type test certificates to be furnished.

34.4 Information and copies of test certificate as in (33.3) above respect of bought out accessories including terminal connectors.

34.5 List of manufacturing facilities available, in this list the bidder shall specifically mention whether lapping machine, vacuum drying plant, air conditioned dust free room with positive air pressure for provision of insulation and winding etc are available with him.

34.6 Level of automation achieved and list of areas where manual processing still exists.

34.7 List of areas in manufacturing process where stage inspection are normally carried out for quality control and details of such tests and inspections.

34.8 Special features provided in the equipment to make it maintenance free.

34.9 List of testing equipment available with the bidder for final testing of transformers and test plant limitation, if any, vis-à-vis the type, special acceptance and routine tests specified in the relevant standards and the present specification. The limitations shall be very clearly brought out in schedule of deviations from specified test requirements.

34.10 The successful bidder shall submit the Routine Test Certificate along with documentary evidence having paid for the excise duty for the following raw materials



**TECHNICAL SPECIFICATION OF 16 AND 25kVA, 11/0.433 kV & 22/ 0.433 kV LEVEL-1 THREE PHASE,
NON SEALED TYPE DISTRIBUTION TRANSFORMERS OUTDOOR TYPE OIL IMMERSED WITHOUT CSP
FEATURE.**

viz Oil, Copper

for conductors, insulating materials, Core materials, Bushing at the time of routine
Testing of the fully assembled transformer.

35.0 Qualifying Requirement: Deleted

36.0 Performance Guarantee:

All transformers supplied against this specification shall be guaranteed for a period of 24 months from the date of receipt of material at concern stores / consignee. However, any engineering error, omission, wrong provisions, etc. which do not have any effect on the time period, shall be attended to as and when observed/ pointed out without any price implication.

**TECHNICAL SPECIFICATION OF 16 AND 25kVA, 11/0.433 kV & 22/ 0.433 kV LEVEL-1
THREE PHASE, NON SEALED TYPE DISTRIBUTION TRANSFORMERS OUTDOOR TYPE OIL
IMMERSED WITHOUT CSP FEATURE.**

Annexure I

Air Pressure Test

Name of Supplier:

Order No.:

Capacity & Voltage Ratio of Distribution Transformer: _____ kVA, ____/0.433 kV Vector
Group Dyn11

Sr. No. of equipment Tested:

Date of Testing:

Reference Standard

All the opening of the transformer tank were closed with suitable gasket, bushing, valves and plugs. The compressor pipe connected at oil filling hole on conservator and a pressure gauge was fitted at air vent plug. The parallel string were placed around the tank, the distance between string and tank as shown in following diagram were recorded before applying the pressure and after releasing pressure.

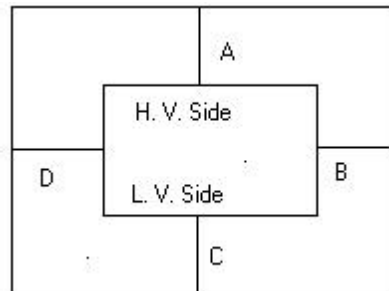

| | | | | |
|--|------------|-------------------------------|---|---------------------|
| Tank Thickness: Side _____ mm. | | Top & Bottom _____ mm | | |
| Test Pressure: _____ kg/cm ² applied for 30 Minutes | | | | |
| | Test Point | Distance before Test In mm | Distance after release of Pressure in mm | Deflection In mm |
| | A | | | |
| | B | | | |
| | C | | | |
| | D | | | |

Permanent Deflection: _____ mm Permissible Limit of

Permanent Deflection as per Specification: mm Test _____

Witnessed by

Tested by



**TECHNICAL SPECIFICATION OF 16 AND 25kVA, 11/0.433 kV & 22/ 0.433 kV LEVEL-1
THREE PHASE, NON SEALED TYPE DISTRIBUTION TRANSFORMERS OUTDOOR TYPE OIL
IMMERSED WITHOUT CSP FEATURE.**

Annexure II

Temperature Rise Test

Name of Supplier:

Order No.:

Capacity & Voltage Ratio of Distribution Transformer: _____ kVA, _____/0.433kV

Vector Group Dyn11

Sr. No. of equipment Tested:

Date of Testing:

Reference Standard

| | H. V. Winding | L. V. Winding |
|---------------------------|---------------|---------------|
| Rated Line Current in Amp | | |

Guaranteed No Load Losses _____ watt

Load Losses _____ watt

Total Losses _____ watt

P.T.Ratio: _____/_____ =

C.T.Ratio: _____/_____ =

Wattmeter Constant _____ =

Total Multiplying Factor (MF) _____ =

| TIME | Ambient Temp. | | | | Top Oil Temp. °C | Rise in Top Oil Temp. °C | Line Voltage in Volts | Line Current in Amps | W1 watts | W2 watts | W3 watts | W1+W2+W3 watt | Multiplying Factor (MF) | Total Watt |
|-------------------------------------|---------------|-------|-------|------------|------------------|--------------------------|-----------------------|----------------------|----------|----------|----------|---------------|-------------------------|------------|
| | T1 °C | T2 °C | T3 °C | Average °C | | | | | | | | | | |
| Reduced to Rated Current _____ amps | | | | | | | | | | | | | | |
| | | | | | | | | | | | | | | |
| | | | | | | | | | | | | | | |

Calculation of Temperature Rise in Winding

LV Winding: Since the resistance of LV winding is less than 0.005 ohm, Temperature Rise in LV Windings taken as temperature rise of oil as per clause no. 4.3 of IS:2026 (Part II)/1977



**TECHNICAL SPECIFICATION OF 16 AND 25kVA, 11/0.433 kV & 22/ 0.433 kV LEVEL-1
THREE PHASE, NON SEALED TYPE DISTRIBUTION TRANSFORMERS OUTDOOR TYPE OIL
IMMERSED WITHOUT CSP FEATURE.**

Temperature Rise in LV Winding = _____ °C

HV Winding Resistance across 1U1V at _____ °C = _____ ohm

Measurement of Hot Resistance of HV Winding after Shut
Down.

| Time | Resistance |
|------|------------|
| | |

Hot winding Resistance at Ambient Temperature _____ °C (from graph) = _____ Ohm

Temperature Rise in H. V. Winding is

$\frac{\text{Hot Resistance} \times (235 + \text{Cold Ambient Temperature}) - (235 + \text{Hot Ambient Temperature})}{\text{Cold Resistance}}$

Results :

- 1) Temperature Rise in Oil = _____ °C
- 2) Temperature Rise in LV Winding = _____ °C
- 3) Temperature Rise in HV Winding = _____ °C

4) Oil leakage test:

The oil leakage test shall be conducted on one unit selected from the offered lot of each rating. Transformer complete in all respects shall be subjected to the pressure of 0.4 kg/cm² and maintained for 8 hours. No leakage should occur.

Test witnessed by

Tested by



**TECHNICAL SPECIFICATION OF 16 AND 25kVA, 11/0.433 kV & 22/ 0.433 kV LEVEL-1
THREE PHASE, NON SEALED TYPE DISTRIBUTION TRANSFORMERS OUTDOOR TYPE OIL
IMMERSED WITHOUT CSP FEATURE.**

**Annexure -III
Guaranteed Technical particulars**

| Sr.No. | Guaranteed Technical Particular | Bidder Submission |
|--------|--|-------------------|
| 1 | Name of Manufacturer. | |
| 2 | Reference Standard | |
| 3 | Whether transformer is Oil Natural Air Natural cooled type(Yes/No) | |
| 4 | Whether transformer is suitable for Indoor /Outdoor installation | |
| 5 | Rating of transformer in KVA | |
| 6 | Primary Voltage in kV | |
| 7 | Secondary Voltage in kV | |
| 8 | Whether neutral is solidly earthed (Yes/No) | |
| 9 | Colour of transformer | |
| 10 | Vector Group | |
| 11 | Approximate overall length of transformer in mm | |
| 12 | Approximate overall breadth of transformer in mm | |
| 13 | Approximate overall height of transformer in mm | |
| 14 | Approximate length of transformer tank in mm | |
| 15 | Approximate breadth of transformer tank in mm | |
| 16 | Approximate height of transformer tank in mm | |
| 17 | Thickness of the side of transformer Tank plate in mm | |
| 18 | Thickness of the bottom of transformer tank plate in mm | |
| 19 | Thickness of the top of transformer tank plate in mm | |
| 20 | Weight of Tank & fittings in kgs | |
| 21 | Total Weight of Transformer in kgs | |
| 22 | Type of Tank (corrugated/conventional) | |
| 23 | Degree of slope to the top plate of Transformer. | |
| 24 | In case of Corrugated tank, Thickness of corrugated sheet (in mm) | |

**TECHNICAL SPECIFICATION OF 16 AND 25kVA, 11/0.433 kV & 22/ 0.433 kV LEVEL-1
THREE PHASE, NON SEALED TYPE DISTRIBUTION TRANSFORMERS OUTDOOR TYPE OIL
IMMERSED WITHOUT CSP FEATURE.**

| | | |
|----|--|--|
| 25 | Name plate details are as per the requirement specified in tender. (Yes/No) | |
| 26 | Total radiating surface of transformertank in Sq. mtrs. | |
| 27 | Core material used & its grade | |
| 28 | Type of core | |
| 29 | Weight of Core in kgs | |
| 30 | No. of steps of core for CRGO core | |
| 31 | Diameter of core in mm | |
| 32 | Effective core area.(sq.cm) | |
| 33 | Flux density in Tesla | |
| 34 | Thickness of core lamination in mm | |
| 35 | The temperature shall in no case reached a value that will damage the core itself, otherparts or adjacent materials(Yes/No) | |
| 36 | Type of connection forH.V. Winding(Delta) (Yes/No) | |
| 37 | Type of connection for L.V.Winding(Star) (Yes/No) | |
| 38 | Material of H.V. winding | |
| 39 | Material of L.V.Winding | |
| 40 | Insulation provided to H.V winding. | |
| 41 | Insulation provided to L.V. winding. | |
| 42 | Current density of H.V. winding(inAmpere/ sq.mm) | |
| 43 | No of LV winding turns | |
| 44 | No of HV winding turns | |
| 45 | Resistance of LVwinding per phase at 20degC in ohms | |
| 46 | Resistance of HV winding per phase at 20degC in ohms | |
| 47 | Current density ofL.V.winding(inAmpere/sq.mm.) | |
| 48 | ClearancebetweenCore&L.V.winding inmm | |
| 49 | ClearancesbetweenL.V.&H.V.winding in mm | |
| 50 | Clearances betweenHV PhasetoPhase in mm | |
| 51 | Clearances between end insulation to Earth in mm | |
| 52 | Clearances between windingtotankinmm (min 30 mm)Yes/No | |
| 53 | Weight of Aluminum/Copper in kgs | |

**TECHNICAL SPECIFICATION OF 16 AND 25kVA, 11/0.433 kV & 22/ 0.433 kV LEVEL-1
THREE PHASE, NON SEALED TYPE DISTRIBUTION TRANSFORMERS OUTDOOR TYPE OIL
IMMERSED WITHOUT CSP FEATURE.**

| | | |
|----|---|--|
| 54 | InterlayerinsulationprovidedinH.V winding todesignforTop&bottom Layer | |
| 55 | Inter layer insulation provided in L.V windingtodesignforTop&bottom layer | |
| 56 | Interlayerinsulationprovidedin betweenalllayerinH.Vwinding | |
| 57 | InterlayerinsulationprovidedinbetweenalllayerinL.Vwinding | |
| 58 | Details of end insulation | |
| 59 | Whether wedges are Providedat 50%turns of the Coil(Yes/ No) | |
| 60 | Insulation materials provided for core | |
| 61 | Length of coil used for HV winding inmeter. | |
| 62 | Crossectionareaofthecoilusedfor HVwinding (sq.mm) | |
| 63 | Length of coil used for LV winding inmeter. | |
| 64 | Size of strip used for LV winding in mm | |
| 65 | No. of conductors in parallel for LVWinding | |
| 66 | TotalcrossectionareaofLVconductor insq.mm | |
| 67 | No. of H.V coils /phase | |
| 68 | Thickness of locking spacers between H.V. coils (in mm) | |
| 69 | Weight of Oil in kgs | |
| 70 | Volume of Oil in Ltrs | |
| 71 | Quantityoftotaloilabsorption(inliters) infirstfilling | |
| 72 | TotaloilVolumeincludingTotalOilabsorption inliters | |
| 73 | Grade of Oil used. | |
| 74 | NameofOil manufacturerstobe supplied. | |
| 75 | BreakdownValuesofOilatthetimeof first filling(kV/mm)considering2.5 mm gap | |
| 76 | Conservator with Oil level indicator (showing three levels) (Yes/ No) | |



**TECHNICAL SPECIFICATION OF 16 AND 25kVA, 11/0.433 kV & 22/ 0.433 kV LEVEL-1
THREE PHASE, NON SEALED TYPE DISTRIBUTION TRANSFORMERS OUTDOOR TYPE OIL
IMMERSED WITHOUT CSP FEATURE.**

| | | |
|----|--|--|
| 77 | Conservator tank to the Transformer with oil level indicator | |
| 78 | Drain Valve (32mm) provided to the transformer tank (Yes/No) | |
| 79 | Earthing terminals with lugs is provided (Yes/No) | |
| 80 | Lifting lugs provided (Yes/No) | |
| 81 | Thermometer pocket is provided (Yes/No) | |
| 82 | Material of HV and LV Bushings and makes thereof | |
| 83 | Reference standard of Bushings | |
| 84 | Rating of L.V. Bushing | |
| 85 | Minimum Creepage Distance of HV Bushing in mm (min. 25 mm per kV) | |
| 86 | Minimum Creepage Distance of LV Bushing in mm (min. 25 mm per kV) | |
| 87 | Rating of H.V. Bushings (in kV) | |
| 88 | Rating of L.V. Bushing (in kV, kA) | |
| 89 | Min. External clearances of H.V. bushing terminals between ph. to ph. (255mm) | |
| 90 | Min. External clearances of H.V. bushing terminals between ph. to earth (140 mm) | |
| 91 | Min. External clearances of L.V. bushing terminals between ph. to ph. (75mm) | |
| 92 | Min. External clearances of L.V. bushing terminals between ph. to earth (40mm) | |
| 93 | Rating of Lightning Arrestors and Make thereof | |
| 94 | Reference Standard of Lightning Arrestors. | |
| 95 | Maximum winding temperature rise in °C over an Ambient temp. of 50°C by Resistance Method | |
| 96 | Maximum temperature rise of Oil in °C over an Ambient temp. of 50°C by thermometer. | |
| 97 | Magnetizing current (No load) in Amps and its % of full load current at rated voltage referred to L.V. side. | |
| 98 | Magnetizing current (No load) in Amps and its % of full load current at maximum voltage (112.5% of rated voltage) referred to L.V. side. | |

**TECHNICAL SPECIFICATION OF 16 AND 25kVA, 11/0.433 kV & 22/ 0.433 kV LEVEL-1
THREE PHASE, NON SEALED TYPE DISTRIBUTION TRANSFORMERS OUTDOOR TYPE OIL
IMMERSED WITHOUT CSP FEATURE.**

| | | |
|-----|--|--|
| 99 | Max core (No load) losses at rated voltage and rated frequency(Watts). | |
| 100 | Max.Total losses (No Load + Load Losses at 75 °C) at 50% loading inWatts | |
| 101 | Max.Total losses (No Load + Load Losses at 75 °C) at 100% loading in Watts | |
| 102 | Efficiencyat75°CatunityP.F.at125% load | |
| 103 | Efficiencyat75°CatunityP.F.at100% load | |
| 104 | Efficiencyat75°CatunityP.F.at75% load | |
| 105 | Efficiency at 75 °C at unity P.F. at 50% Load | |
| 106 | Efficiencyat75°CatunityP.F.at25% load | |
| 107 | Efficiencyat75°Cat0.8P.F.lagat125% load | |
| 108 | Efficiencyat75°Cat0.8P.F.lagat100% load | |
| 109 | Efficiencyat75°Cat0.8P.F.lagat75% load | |
| 110 | Efficiencyat75°Cat0.8P.F.lagat50% load | |
| 111 | Efficiencyat75°Cat0.8P.F.lagat25% load | |
| 112 | Efficiencyat75°Cat0.8P.F.leadingat 125% load | |
| 113 | Efficiencyat75°Cat0.8P.F.leadingat 100% load | |
| 114 | Efficiencyat75°Cat0.8P.F.leadingat 75% load | |
| 115 | Efficiencyat75°Cat0.8P.F.leadingat 50%load | |
| 116 | Efficiencyat75°Cat0.8P.F.leadingat 25 % load | |
| 117 | Regulation at Unity P.F (in %) | |
| 118 | Regulation at 0.8 P.F. lag. (in %) | |
| 119 | Regulation at 0.8 P.F. leading. (in %) | |
| 120 | % Impedance value at 75°C | |
| 121 | Separate source power frequency withstandtestforHVfor1minutein kv(min) | |
| 122 | Separate source power frequency withstandtestforLVfor1minutein kv(min) | |

**TECHNICAL SPECIFICATION OF 16 AND 25kVA, 11/0.433 kV & 22/ 0.433 kV LEVEL-1
THREE PHASE, NON SEALED TYPE DISTRIBUTION TRANSFORMERS OUTDOOR TYPE OIL
IMMERSED WITHOUT CSP FEATURE.**

| | | |
|-----|---|--|
| 123 | Induced overvoltage withstand test for 1min. specify voltage frequency, time for test. | |
| 124 | Impulse test value (in kVp) . | |
| 125 | The test certificates of Aluminium/copper conductor, core, insulating paper, porcelain bushings, steel plate used for enclosure of offer transformer is enclosed along with the offer in soft copy. (Yes/ No) | |
| 126 | All type test report of type tests carried out on transformer at NABL laboratory shall be submitted along with the offer as per cl. XXII(c) of Section (I) i.e. Instructions to tenderers. (Yes/ No) | |
| 127 | Air pressure test and temperature rise test shall be conducted as per format enclosed with the technical specification along with the offer (Yes/No) | |
| 128 | All drawings shall be furnished for each offered item separately along with this offer (Yes/No) | |
| 129 | Oil absorption calculations sheet shall be furnished for each offered item separately along with this offer (Yes/ No) | |
| 130 | Heat dissipation calculation shall be furnished for each offered item separately along with this offer (Yes/ No) | |
| 131 | Flux density calculation sheet with no. of Primary & Secondary turns shall be furnished for each offered item Separately along with this offer (Yes/ No) | |
| 132 | Calculation sheet for 112.5% of Rated V/f ratio (over fluxing calculation sheet) shall be furnished for each offered item Separately along with this offer (Yes/ No) | |
| 133 | Required documents, plant and machinery, list of order executed/under execution shall be furnished for each offered item separately along with this offer (Yes/ No) | |
| 134 | The information required under Quality Assurance shall be submitted with the offer in physical format & soft copy (Yes/ No) | |



**TECHNICAL SPECIFICATION OF 16 AND 25kVA, 11/0.433 kV & 22/ 0.433 kV LEVEL-1
THREE PHASE, NON SEALED TYPE DISTRIBUTION TRANSFORMERS OUTDOOR TYPE OIL
IMMERSED WITHOUT CSP FEATURE.**

| | | |
|-----|--|--|
| 135 | The cost data in the prescribed format shall be submitted with offer in physical format & soft copy (Yes/No) | |
| 136 | The performance Guarantee of the transformers in years | |
| 137 | Power frequency withstand voltage dry & wet in kV(rms) for H.V Bushing | |
| 138 | Dry lightning impulse withstand voltage test in kV(peak) Stating the waveform adopted for H.V. bushing | |
| 139 | Oil filling hole with cap (On Conservator) is provided (Yes/No) | |
| 140 | Quantity of Silica Gel filled in Breather and makes | |
| 141 | No. of radiators provided and location with arrangement | |
| 142 | Thickness of the radiator of transformer in mm | |
| 143 | No of radiator fins | |

Annexure IV- Technical specification for QR Code generation

1. SCOPE: The QR Code Generation for Distribution Transformer Identification should be easy to create, compact in size and friendly user. Being compact in size the QR Code requires less space.

2. SERVICE CONDITIONS:

The QR Code laminated P-Touch labels shall be suitable for satisfactory operation under the following tropical conditions.

| | | |
|-----|--|----------|
| 2.1 | Maximum ambient temperature (Degree C) | 50 |
| 2.2 | Maximum temperature in shade (Degree C) | 45 |
| 2.3 | Minimum Temperature (Degree C) | 3.5 |
| 2.4 | Relative Humidity (percent) | 10 to 95 |
| 2.5 | Maximum Annual rain fall (mm) | 1450 |
| 2.6 | Maximum wind pressure (kg/sq.m) | 150 |
| 2.7 | Maximum altitude above mean sea level (Meter) | 1000 |
| 2.8 | Isoceranic level (days per year) | 50 |
| 2.9 | Seismic level (Horizontal Acceleration) | 0.3 g |

Moderately hot and humid tropical climate conducive to rust and fungus growth

3. GENERAL TECHNICAL REQUIREMENT:

The QR Code shall be laminated P-Touch labels. The QR Code shall be 2D square barcode which can be store data in encoded format. This saves space and giving specified information to users. This QR Code, if scanned with mobile shall be convert encoded data readable text without error.

4. TECHNICAL DETAILS :

The QR Code laminated P-Touch labels shall be temperature resistant, fade resistant, water resistant, chemical resistant, scratch (abrasion) proof and strong adhesion.

5. TECHNICAL DATA :

The QR Code laminated P-Touch labels with following data shall be provided on transformer.

- 1) Name of Manufacture :
- 2) Rating :
- 3) Sr. No. :
- 4) Date of Manufacturing :
- 5) A/T No. :

6. LOCATION OF QR CODE :

The QR Code laminated P-Touch labels shall be located below the Name Plate on transformer body. It should be clearly visible.

The QR Code laminated P-Touch labels location as below :

MFD. BY:-

| | | | |
|-------------------------------------|---|-------------------------------------|--------------------------------------|
| 3 PHASE AL WOUND TRANSFORMER | | | |
| TYPE | OUTDOOR | | |
| STANDARD | IS-1180 PART-1 | ENERGY EFFICIENCY LEVEL | 2 |
| kVA | 100 | MAX. TOTAL LOSSES AT 50% RATED LOAD | 475 |
| VOLTS-AT NO LOAD | HV | 11000 | MAX. TOTAL LOSSES AT 100% RATED LOAD |
| | LV | 433 | 1650 |
| BIL | HV | 75 | TYPE OF COOLING |
| | LV | — | ONAN |
| AMPERS | HV | 5.25 | TEMP RISE |
| | LV | 133.34 | OIL °C 35 |
| FREQUENCY Hz | 50 | WDG °C | 40 |
| VECTOR GROUP | Dyn-11 | MASS OF OIL | Kg 179 |
| IMPEDANCE VOLT % | | TOTAL MASS | Kg 696 |
| CUSTOMER | MAHARASHTRA STATE ELECTRICITY DISTRIBUTION CO. LTD. | | |
| ORDER NUMBER | LOA NO. | VOL OF OIL | L 219 |
| | | MONTH & YEAR OF MFG | 12/2017 |
| | | SERIAL NO. | DI - |

MADE IN INDIA

CONNECTIONS & VECTOR DIAGRAM :



QRcode for details.



Drawings:- Indicative drawing are given for reference

| | | | | | | | | | | | | | | | | | | | | | | | | | | | | | | | | | | | |
|---|---|-------------------------|---------------------|--------------------------|----|--------------------|--------------|---------------------------|----|--------------------|------------|---------------------|----|-------------------|--------------|-------------------|--------------|--------------------|-------------------|----------------------|--|-----------------|--|---------------------|---|----------|--|--------|--------------------------------------|--------|---|-------|---|--|--|
| <p>Ø3.6mm</p> <p>MFD BY -</p> <p style="text-align: right;">IS 1180 Part 1, 2014</p> <p>For Detail Of the BIS Certification Marks Scheme Refer www.bis.org.in 3 PHASE ALU WOUND DISTRIBUTION TRANSFORMER STANDARD IS 1180 (PART-1) 2014</p> <table style="width: 100%; border: none;"> <tr> <td style="width: 50%;">KVA</td> <td style="width: 50%;">ENERGY EFFICIENCY LEVEL</td> </tr> <tr> <td>VOLTS AT NO LOAD HV</td> <td>MAX. TOTAL LOSSES AT 50%</td> </tr> <tr> <td>LV</td> <td>RATED LOAD AT 75°C</td> </tr> <tr> <td>BIL (KVP) HV</td> <td>MAX. TOTAL LOSSES AT 100%</td> </tr> <tr> <td>LV</td> <td>RATED LOAD AT 75°C</td> </tr> <tr> <td>AMPERES HV</td> <td>TEMP. RISE OVER OIL</td> </tr> <tr> <td>LV</td> <td>AMBIENT 50°C. WDG</td> </tr> <tr> <td>FREQUENCY Hz</td> <td>MASS OF OIL (Kgs)</td> </tr> <tr> <td>VECTOR GROUP</td> <td>TOTAL WEIGHT (Kgs)</td> </tr> <tr> <td>IMPEDANCE VOLT. %</td> <td>VOLUME OF OIL (Ltrs)</td> </tr> <tr> <td></td> <td>TYPE OF COOLING</td> </tr> <tr> <td></td> <td>MONTH & YEAR OF MFG</td> </tr> </table> <p>SERIAL NO: *</p> <p>CUSTOMER: MAHARASHTRA STATE ELECTRICITY DISTRIBUTION CO. LTD</p> <p>ORDER NO.:</p> <p style="text-align: center;">MADE IN INDIA</p> <p>TERMINAL MARKING & DIAGRAM</p> <p style="text-align: center;">165 175</p> <p style="text-align: center;">95</p> <p style="text-align: center;">105</p> | KVA | ENERGY EFFICIENCY LEVEL | VOLTS AT NO LOAD HV | MAX. TOTAL LOSSES AT 50% | LV | RATED LOAD AT 75°C | BIL (KVP) HV | MAX. TOTAL LOSSES AT 100% | LV | RATED LOAD AT 75°C | AMPERES HV | TEMP. RISE OVER OIL | LV | AMBIENT 50°C. WDG | FREQUENCY Hz | MASS OF OIL (Kgs) | VECTOR GROUP | TOTAL WEIGHT (Kgs) | IMPEDANCE VOLT. % | VOLUME OF OIL (Ltrs) | | TYPE OF COOLING | | MONTH & YEAR OF MFG | <p>NOTE:-</p> <ol style="list-style-type: none"> 1) (*) MARKED VALUE WILL BE PUNCHED AT THE TIME OF DISPATCH. 2) MATERIAL ALUMINIUM ANODIZED. 3) THICKNESS -18 SWG. MIN. 4) ALL DIMENSIONS ARE IN mm UNLESS OTHERWISE STATED. <p style="text-align: center;">QUANTITY: NOS</p> <div style="border: 1px solid black; width: 100%; height: 50px; margin-top: 20px;"></div> <p style="text-align: center;">SIGNATURE OF AUTHORIZED PERSON & STAMP OF THE FIRM</p> <table border="1" style="width: 100%; border-collapse: collapse; margin-top: 20px;"> <tr> <td style="width: 30%;">CUSTOMER</td> <td>MAHARASHTRA STATE ELECTRICITY DISTRIBUTION CO. LTD</td> </tr> <tr> <td>DRN BY</td> <td>RATING & DIAGRAM DRAWING.</td> </tr> <tr> <td>CHD BY</td> <td>6 KVA, 110/433KV 3PHASE, ALU WOUND, CRGO CORE, DIST TRANSFORMER</td> </tr> <tr> <td>SCALE</td> <td>ENERGY EFFICIENCY LEVEL- 2 AS PER IS 1180 (PART-1) 2014</td> </tr> <tr> <td></td> <td>DRAWING NO. - MSEDCL/HVDS/16/11 3φ/EEL2/01</td> </tr> </table> | CUSTOMER | MAHARASHTRA STATE ELECTRICITY DISTRIBUTION CO. LTD | DRN BY | RATING & DIAGRAM DRAWING. | CHD BY | 6 KVA, 110/433KV 3PHASE, ALU WOUND, CRGO CORE, DIST TRANSFORMER | SCALE | ENERGY EFFICIENCY LEVEL- 2 AS PER IS 1180 (PART-1) 2014 | | DRAWING NO. - MSEDCL/HVDS/16/11 3φ/EEL2/01 |
| KVA | ENERGY EFFICIENCY LEVEL | | | | | | | | | | | | | | | | | | | | | | | | | | | | | | | | | | |
| VOLTS AT NO LOAD HV | MAX. TOTAL LOSSES AT 50% | | | | | | | | | | | | | | | | | | | | | | | | | | | | | | | | | | |
| LV | RATED LOAD AT 75°C | | | | | | | | | | | | | | | | | | | | | | | | | | | | | | | | | | |
| BIL (KVP) HV | MAX. TOTAL LOSSES AT 100% | | | | | | | | | | | | | | | | | | | | | | | | | | | | | | | | | | |
| LV | RATED LOAD AT 75°C | | | | | | | | | | | | | | | | | | | | | | | | | | | | | | | | | | |
| AMPERES HV | TEMP. RISE OVER OIL | | | | | | | | | | | | | | | | | | | | | | | | | | | | | | | | | | |
| LV | AMBIENT 50°C. WDG | | | | | | | | | | | | | | | | | | | | | | | | | | | | | | | | | | |
| FREQUENCY Hz | MASS OF OIL (Kgs) | | | | | | | | | | | | | | | | | | | | | | | | | | | | | | | | | | |
| VECTOR GROUP | TOTAL WEIGHT (Kgs) | | | | | | | | | | | | | | | | | | | | | | | | | | | | | | | | | | |
| IMPEDANCE VOLT. % | VOLUME OF OIL (Ltrs) | | | | | | | | | | | | | | | | | | | | | | | | | | | | | | | | | | |
| | TYPE OF COOLING | | | | | | | | | | | | | | | | | | | | | | | | | | | | | | | | | | |
| | MONTH & YEAR OF MFG | | | | | | | | | | | | | | | | | | | | | | | | | | | | | | | | | | |
| CUSTOMER | MAHARASHTRA STATE ELECTRICITY DISTRIBUTION CO. LTD | | | | | | | | | | | | | | | | | | | | | | | | | | | | | | | | | | |
| DRN BY | RATING & DIAGRAM DRAWING. | | | | | | | | | | | | | | | | | | | | | | | | | | | | | | | | | | |
| CHD BY | 6 KVA, 110/433KV 3PHASE, ALU WOUND, CRGO CORE, DIST TRANSFORMER | | | | | | | | | | | | | | | | | | | | | | | | | | | | | | | | | | |
| SCALE | ENERGY EFFICIENCY LEVEL- 2 AS PER IS 1180 (PART-1) 2014 | | | | | | | | | | | | | | | | | | | | | | | | | | | | | | | | | | |
| | DRAWING NO. - MSEDCL/HVDS/16/11 3φ/EEL2/01 | | | | | | | | | | | | | | | | | | | | | | | | | | | | | | | | | | |

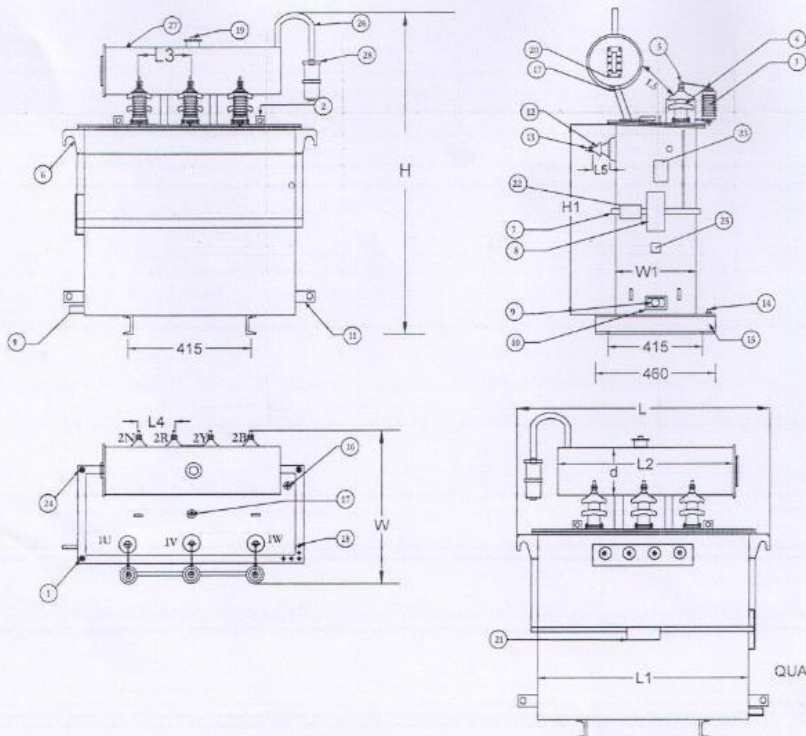

| Sl. NO. | ACCESSORIES. | QTY | DETAIL |
|---------|--|-----|---------------|
| 1 | SEALING BOLT | 2 | M.S. |
| 2 | LIFTING LUGS (FOR TOP COVER) 8MM | 2 | M.S. |
| 3 | LIGHTNING ARRESTORS | 3 | 9KV / 5KA |
| 4 | HV BUSHING 12 KV, 250 AMP | 3 | PORCELAIN |
| 5 | HV TERMINAL WITH STUDS - M12 | 3 | BRASS |
| 6 | LIFTING LUGS 8 MM FOR TANK | 2 | M.S. |
| 7 | REINFORCING ANGLE (25X25X5 MM) | 1 | M.S. |
| 8 | RATING & DIAGRAM PLATE- RIVETED/SCREWED | 1 | ANODIZED AL |
| 9 | DRAIN VALVE (32 MM) | 1 | T- VALVE |
| 10 | DRAIN VALVE METALLIC COVER SPOT WELDED | 1 | M.S. |
| 11 | PULLING LUGS 8 MM | 4 | M.S. |
| 12 | LV BUSHINGS 1KV/250 AMP | 4 | PORCELAIN |
| 13 | LV TERMINAL STUDS - M12 | 4 | BRASS |
| 14 | EARTHING TERMINAL 10 MM | 2 | M.S. |
| 15 | BASE CHANNEL- 75MMX45MM WITH HOLES | 2 | M.S. |
| 16 | THERMOMETER POCKET WITH CAP | 1 | M.S. |
| 17 | AIR RELEASE PLUG- 1/2" DIA. | 1 | M.S. |
| 18 | TOP COVER FIXING BOLTS- 1/2" DIA WITH PLAIN WASHER | — | GI |
| 19 | OIL FILLING HOLE WITH CAP /GAUGE FOR TEST | 1 | M.S. |
| 20 | OIL LEVEL INDICATOR (L- 30, 90) | 1 | M.S. |
| 21 | CLAMP SUPPORT FOR LT CABLE CLAMP | 1 | M.S. |
| 22 | 2 YEARS GARRANTY PLATE | 1 | M.S. |
| 23 | BEE LABLE | 1 | STRIKER |
| 24 | ANTI THEFT STAILNESS STEEL FASTNERS WITH BREAK AWAY AT TOP COVER | 4 | S.S |
| 25 | QR CODE LABLE | 1 | STRIKER |
| 26 | BREATHER PIPE | 1 | M.S. |
| 27 | CONSERVATOR TANK (SIZE D-175 X L-500 MM) | 1 | M.S. |
| 28 | SILICA GEL BREATHER 250GRMS | 1 | POLYPROPYLENE |

| RADIATING SURFACE AREA | | TANK TOTAL | 1.278 Sq. mtrs |
|------------------------|------------------------|------------|----------------|
| WEIGHT IN KGS | | | |
| 1. | CORE | 96 | |
| 2. | WINDINGS | 18 | |
| 3. | CORE & ASSEMBLY WEIGHT | 114 | |
| 4. | TANK & FITTINGS | 90 | |
| 5. | OIL in Kgs | 96 | |
| 6. | TOTAL WEIGHT | 300 | |

| DIMENSIONS ARE IN mm | | | |
|----------------------|------|----|----------|
| OVERALL TANK | | | |
| L | 415 | L1 | 716 |
| W | 495 | W1 | 285 |
| H | 1070 | H1 | 290(Avg) |

| MIN. BUSHING CLEARANCE IN AIR | | THICKNESS ARE IN mm | |
|-------------------------------|--------------------|-----------------------|------|
| L3 (H.V.) | 255 PHASE TO PHASE | TANK SIDE PLATES MIN | 3.15 |
| L4 (L.V.) | 75 PHASE TO PHASE | TOP AND BOTTOM PLATES | 5 |
| L5 (H.V.) | 140 PHASE TO EARTH | MIN. | |
| L6 (H.V.) | 40 PHASE TO EARTH | | |

| DIMENSION OF CONSERVATOR | |
|--------------------------|--------|
| INSIDE DIAMETER(D) | 175mm |
| LENGTH (L2) | 500 mm |
| CAPACITY (TOTAL) | 12 LTR |

NOTE:
 1. WIDTH OF TOP COVER BEND PLATE - MIN. 25 mm.
 2. COLOR OF TRANSFORMER- AIRCRAFT BLUE SHED NO.108 OF IS: 5

16 kVA 11/0.433 kV Three Phase Aluminium wound CRGO Core Dist. Transformer

QUANTITY: NOS

SIGNATURE OF AUTHORIZED PERSON & STAMP OF THE FIRM

WINDING & CONSTRUCTIONAL DETAILS

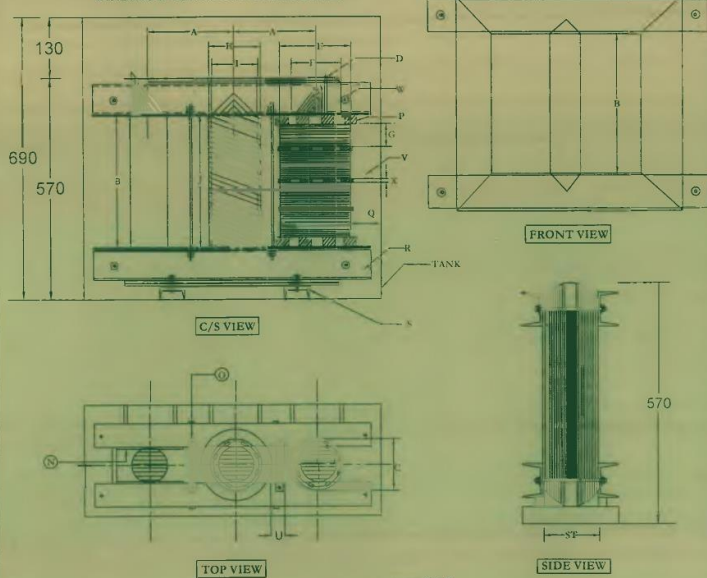

| DESCRIPTION | UNIT | AS PER OFFER TECH. SPECIFICATIONS |
|-------------|---------------------|-----------------------------------|
| CORE | | II |
| A | LEG CENTRE | mm |
| B | WINDOW HEIGHT | mm |
| C | CORE CIRCLE | mm |
| II | NO OF STEPS | No. |
| | EFFECTIVE CORE AREA | cm ² |

| HV COIL | | |
|--------------------------|------------------------------|-----------------|
| NO. OF HV COIL PER PHASE | | |
| I | OUTER DIAMETER | mm |
| T | INNER DIAMETER | mm |
| G | AXIAL LENGTH | mm |
| | CONDUCTOR CROSS SECTION/SIZE | mm ² |
| | CONDUCTOR INSULATION | DPC |
| | CONDUCTOR MATERIAL | AL |
| | RESISTANCE AT 20°C PER PHASE | Ohms |

| LV COIL | | |
|---------|------------------------------|-----------------|
| II | OUTER DIAMETER | mm |
| I | INNER DIAMETER | mm |
| J | AXIAL LENGTH | mm |
| | CONDUCTOR CROSS SECTION/SIZE | mm ² |
| | CONDUCTOR INSULATION | DPC |
| | CONDUCTOR MATERIAL | AL |
| | RESISTANCE AT 20°C PER PHASE | Ohms |

| INSULATION | | |
|------------|-------------------------------------|------------|
| K | WRAP ON CORE | NOS. |
| K1 | CLEARANCE TO LV COIL | mm |
| L | WEDGES BETWEEN HV & LV COILS | mm |
| M | CLEARANCE BETWEEN HV & LV | mm |
| M1 | CLEARANCE BETWEEN HV PHASE TO PHASE | mm |
| N | FRAME CHANNEL INSULATION | mm |
| O | PHASE BARRIER | mm |
| P | END INSULATION | mm |
| Q | CLEARANCE TO TANK WALL | mm |
| R | CORE FIXING CHANNEL SIZE | mm |
| S | BASE CHANNEL SIZE | mm |
| T | NO. OF SPACER BETWEEN HV AXIAL COIL | PER CIRCLE |
| U | INTER PHASE CLEARANCE | mm |
| V | TIE ROD SIZE | mm |
| W | CORE BOLT SIZE | mm |
| X | INTER COIL INSULATION | mm |

NOTE

- CORE CLAMPS ARE PAINTED WITH OIL RESISTANCE PAINT OR VARNISHED.
- ALL TOP & BOTTOM YOKE BOLTS, NUTS, TIE RODS ARE PAINTED OR VARNISHED.
- MAKE OF INSULATION CRAFT PAPER- MUNKSJO/RAMAN/AMITOSATC.
- MAKE OF PRESS BOARD - RAMAN / SENAPATHY/UMANG RAJ TECHN/ KUBERA INNOVATIVE.
- NO NEGATIVE TOLERANCE ON MINIMUM SPECIFIED PARAMETER.
- ALL HV INTER COIL CONNECTION SHALL BE DONE BY SOLDERING / BRAZING & CRUW'ING.
- HV DELTA CONNECTION SHALL BE DONE BY SOLDERING / BRAZING.
- DELTA LEAD FROM DELTA JOINT TO BUSHING STEM BY BRAZING
- LV STAR POINT BY BRAZING & CRUW'ING.
- LV WINDING TO LV BUSHING STEM BY "L" SHAPED AL FLAT BRAZING
- "L" SHAPED AL FLAT CLAMPED TO LV BUSHING METAL PART USING NUT, LOCK NUT, WASHERS.
- L&T ALKAPPEE AL BRAZING ROD WITH FLUX USED FOR BRAZING.

QUANTITY: NOS

SIGNATURE
OF AUTHORISED
PERSON & STAMP
OF THE FIRM

| | |
|----------|--|
| CUSTOMER | MAHARASHTRA STATE ELECTRICITY DISTRIBUTION CO. LTD |
| DRN BY | CORE & COIL ASSEMBLY DRAWING |
| CHD BY | 16 KVA, 11/0.433KV, 3PHASE, ALU WOUND, CRGO CORE, DIST TRANSFORMER |
| SCALE | (ENERGY EFFICIENCY LEVEL-2, AS PER IS:1180 (PART-1), 2014) |
| | DRAWING NO- MSEDCL/HVDS/16/11 3φ/EE2/03 |

| SR. NO. | DESCRIPTION | TECHNICAL DETAILS |
|---------|---|------------------------|
| | | AS PER OFFER |
| 1. | PRIMARY VOLTAGE (KV) | 11 KV |
| 2. | SECONDARY VOLTAGE (KV) | 0.433 KV |
| 3. | RATING (KVA) | 16 KVA |
| 4. | VECTOR GROUP | Dny, 11 |
| 5. | CONFORMING TO I.S.S | IS: 1180 & PART-1 2014 |
| 6. | PERMISSIBLE VOLTAGE FLUCTUATION % | 12.5% |
| 7. | TEMPERATURE RISE OF OIL OVER AMBIENT 50°C | 35 |
| 8. | TEMPERATURE RISE OF WINDING OVER AMBIENT 50°C | 40 |
| 9. | THICKNESS OF CORE LAMINATION | 0.27 mm |
| | a) CORE MATERIAL | CRGO ANNEALED STEEL |
| | b) PRINCIPLE SOURCE OF CORE MATERIAL | IMPORTED |
| | c) GRADE OF LAMINATION | M4 |
| | d) FLUX DENSITY W/m ² | 1.69 Max |
| | e) NO. OF STEPS OF CORE (NOS.) | 6 |
| 10. | % IMPEDANCE | 4.5% ±10% |
| 11. | CORE DIMENSIONS (Lc X Wh X Cd) | 225 X 380 X 75.5 |

| STEP NO. | 1 | 2 | 3 | 4 | 5 | 6 |
|-------------------------------|-------|------|------|------|------|------|
| L mm. | 70 | 65 | 60 | 50 | 40 | 30 |
| W mm. | 28.1 | 10 | 7.3 | 10.5 | 7.3 | 5.4 |
| CROSS SECTION Cm ² | 19.67 | 6.50 | 4.38 | 5.25 | 2.92 | 1.62 |

TOTAL CROSS SECTION AREA Cm² = 40.34

EFFECTIVE CORE AREA = 40.34 X 0.97

= 39.129 Cm²

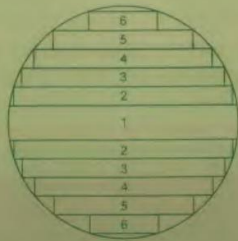

| SR. NO. | DESCRIPTION | AS PER OFFERED | |
|---------|--|----------------|--------------|
| | | H.V. | L.V. |
| 1. | WINDING | | |
| | a) MATERIAL | ALU | ALU |
| | b) SPECIFIC CONDUCTIVITY | | |
| | c) CONDUCTOR SIZE IN mm | 0.87 | 6.8X3.4X1 |
| | d) CONDUCTOR CROSS SECTION mm ² | 0.590 | 22.26 |
| | e) INSULATION MATERIAL | DPC | DPC |
| | f) CURRENT DENSITY A/mm ² Max | 1.3 | 1.3 |
| | g) NO. OF TURNS | 8272 | 188 |
| | h) OUTER DIAMETER mm | 210 | 113 |
| | i) INSIDE DIAMETER mm | 135 | 82.5 |
| | j) AXIAL LENGTH mm | 78 PER COIL | 361 PER COIL |
| | k) NO. OF COIL PER PHASE NO. | 4 | 1 |
| | l) RESISTANCE PER PHASE Ohms at 75°C | 215 | 0.074 |

| 2. | BUSHING | AS PER OFFERED | |
|----|---|----------------|---|
| | | HV | LV |
| | MINIMUM CREEPAGE DISTANCE IN MM | 305 mm | 65 mm |
| 3. | LOSSES | | |
| | NO LOAD LOSS | | 60 WATTS |
| | TOTAL LOSSES AT 75°C AT 50% LOAD (Watts) | | 135 (MAX) |
| | TOTAL LOSSES AT 75°C AT 100% LOAD (Watts) | | 440 (MAX) |
| 4. | TANK | | |
| | SIDE WALL THICKNESS mm.(MIN) | | 3.15 |
| | TOP & BOTTOM PLATE THICKNESS mm.(MIN) | | 5 |
| 5. | OIL USED | | |
| | NAME OF MANUFACTURER | | SAVITA/COLUMBIA/RAJAJAPAR/ GP PETROLIUM |
| | GRADE | | MINERAL OIL CONFORMING TO IS 335 AMENDED UPTO DATED |
| 6. | VOLUME (LITRE'S) | | |
| | IN TANK | | 85 |
| | TOTAL | | 85 |

QUANTITY: NOS

SIGNATURE
OF AUTHORIZED
PERSON & STAMP
OF THE FIRM

| | |
|----------|--|
| CUSTOMER | MAHARASHTRA STATE ELECTRICITY DISTRIBUTION CO. LTD |
| DRN BY | TECHNICAL SPECIFICATION DRAWING |
| CHD BY | 16 KVA, 11/0.433KV, 3PHASE, ALU WOUND, CRGO CORE, DIST TRANSFORMER |
| SCALE | (ENERGY EFFICIENCY LEVEL- 2 , AS PER IS: 1180 (PART-1) 2014 |
| | DRAWING NO. - MHEDCL/HVDS/16/11 3p/EEL2/04 |

CREEPAGE DISTANCE DRAWING OF LV BUSHING 1.0KV/250 Amps.

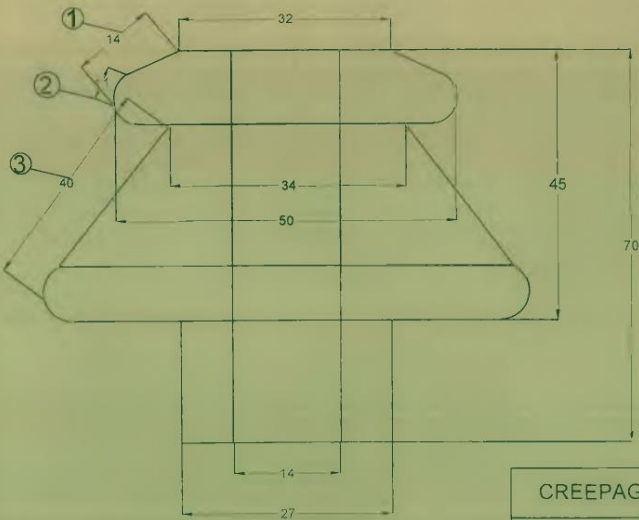

UPPER INSULATOR

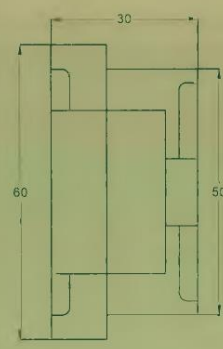

LOWER INSULATOR

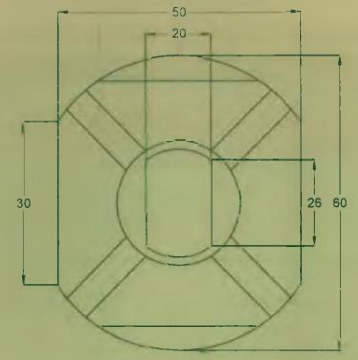

| CREEPAGE DISTANCE | |
|-------------------|------------|
| POINT NO. | DIMENSIONS |
| 1 | 14 |
| 2 | 11 |
| 3 | 40 |
| TOTAL | 65 mm |

QUANTITY NOS

SIGNATURE OF AUTHORIZED PERSON & STAMP OF THE FIRM

NOTE:

1. COLOR- BROWN GLAZED
2. CREEPAGE DISTANCE -25mm/KV(Min.)
3. AS PER IS:3347 (PART-I/SECI)
- 4.ALL DIMENSIONS IN mm.
5. RATED VOLTAGE- 1.0 KV
6. RATED CURRENT- 250 AMP.
7. WEIGHT OF BUSHING ASSEMBLY- 0.7Kg. (APPROX.)
8. PERFORMANCE REQUIRMENTS OF THE BUSHING SHALL CONFORM TO IS: 2099-1996
9. TOTAL CREEAPGE DISTANCE- 65mm.
10. ALL DIMENSIONS ARE IN mm.

| | |
|----------|--|
| CUSTOMER | MAHARASHTRA STATE ELECTRICITY DISTRIBUTION CO.LTD |
| DRN BY | CREEPAGE DISTANCE DRAWING OF |
| CHD BY | LV BUSHING 1.0KV/250 Amps |
| SCALE | 16 KVA, 11/0.433KV, 3PHASE ALU WOUND CRGO CORE, 3ST TRANSFORMER (ENERGY EFFICIENCY LEVEL 2 AS PER IS:1180 (PART-1) 2014) |
| | DRAWING NO - MSEDCL/HVDS/16/11 3φ/EEL2/08 |

TRANSFORMER LV BUSHING ASSEMBLY DRAWING AS PER IS: 3347

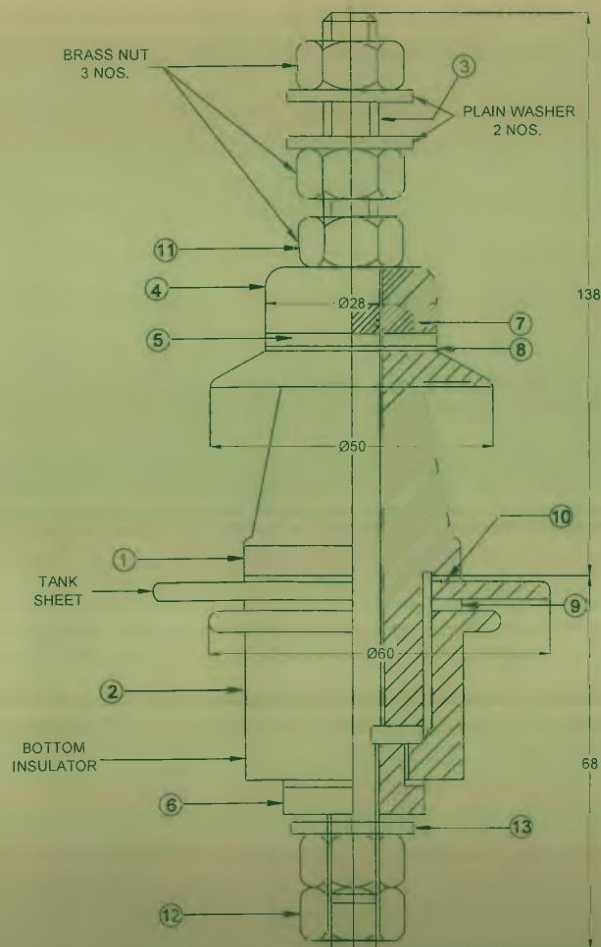

ELECTRICAL CHARECTERISTICS:

1. RATED VOLTAGE 1KV
2. RATED CURRENT: 250 Amp
3. POWER FREQUENCY WITHSTAND VOLTAGE: 3KV
4. CREEPAGE DISTANCE: 65 mm.

NOTE:

PERFORMANCE REQUIREMENTS OF THE BUSHING SHALL CONFIRM TO IS: 7421- 1988

MAKE: JAIPUR/TAYAL/BIKANER/TEK MEK/RR/SHINE/JS GROUP/RR.

| SR.NO. | DESCRIPTION | MATERIAL | QUANTITY |
|--------|-------------------------------|------------------|----------|
| 1 | UPPER INSULATOR | PORCELAIN | 1 |
| 2 | LOWER INSULATOR | PORCELAIN | 1 |
| 3 | STEM- (M12x1.75) (E. TINNING) | BRASS | 1 |
| 4 | TOP END WASHER (E. TINNING) | BRASS | 1 |
| 5 | STEM WASHER (E. TINNING) | BRASS | 1 |
| 6 | BOTTOM NUT (E. TINNING) | BRASS | 1 |
| 7 | SEALING WASHER (STEM) | SYNTHETIC RUBBER | 1 |
| 8 | SEALING GASKET WASHER | NRBC | 1 |
| 9 | SEALING GASKET WASHER | NRBC | 1 |
| 10 | SEALING GASKET WASHER | NRBC | 1 |
| 11 | HEXAGONAL NUT M-12 | BRASS | 3 |
| 12 | HEXAGONAL LOCKING NUT M-12 | BRASS | 2 |
| 13 | PLAIN WASHER (TYPE- N) | BRASS | 3 |

QUANTITY. NOS

SIGNATURE
OF AUTHORIZED
PERSON & STAMP
OF THE FIRM

| | |
|---|--|
| CUSTOMER | MAHARASHTRA STATE ELECTRICITYDISTRIBUTION CO.LTD |
| DRN BY | LV BUSHING ASSEMBLY DRAWING |
| CHD BY | 16 KVA 11/0.433KV, 3PHASE, ALU WOUND, CRGO CORE, DIST |
| SCALE | TRANSFORMER (ENERGY EFFICIENCY LEVEL - 2 , AS PER IS:1180 (PART-1):2014 |
| DRAWING NO:- MSEDCL/HVDS/16/11 3φ/EEL2/07 | |

NOTE:

1. DIMENSIONS ARE CONFORMING TO IS: 3347 (PART-III/SEC.1)- 1988.
2. COLOUR: DARKEN BROWN
3. CREEPAGE DISTANCE: 305mm. (MIN.)

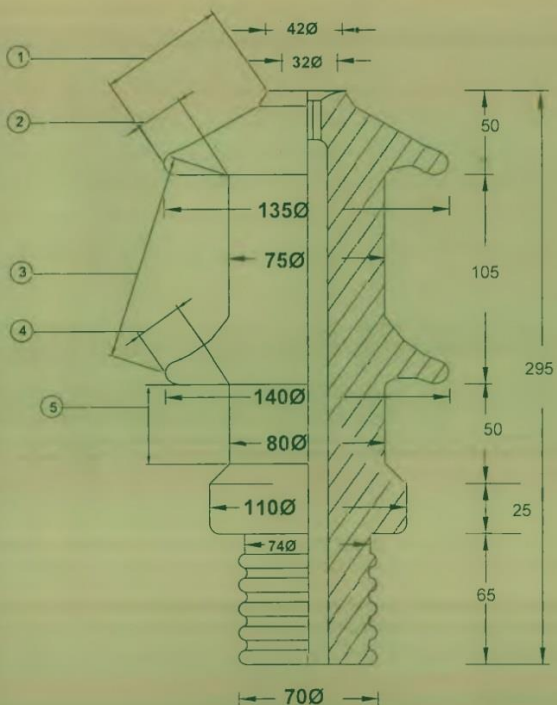

ALL DIMENSIONS ARE IN mm.

| | |
|--|--------------------------|
| RATED RATING | 12 KV/250A |
| STANDARD APPLICABLES IS | IS- 3347 (PART-III)/2009 |
| ONE MINUTE DRY P.F.VOLTAGE WITHSTAND | 28 KV (RMS) |
| ONE MINUTE WET P.F.VOLTAGE WITHSTAND | 28 KV (RMS) |
| 1.2/50 MICRO. SEC. IMPULSE VOLTAGE WITHSTAND | 75 KVP |
| WEIGHT OF ASSEMBLED BUSHING | 3.54 Kg |
| TOTAL CREEPAGE DISTANCE (AIR) 25mm/kv | 305 mm. |

| CREEPAGE DISTANCE | |
|-------------------|------------|
| POINT NO. | DIMENSIONS |
| 1 | 79 |
| 2 | 30 |
| 3 | 80 |
| 4 | 43 |
| 5 | 30 |
| 6 | 43 |
| TOTAL | 305 mm |

SIGNATURE
OF AUTHORIZED
PERSON & STAMP
OF THE FIRM

QUANTITY: NOS

| | |
|----------|---|
| CUSTOMER | MAHARASHTRA STATE ELECTRICITY DISTRIBUTION CO.LTD |
| DRN BY | CREEPAGE DISTANCE DRAWING OF HV BUSHING 12KV/250 Amps |
| CHD BY | 16 KVA, 11/0.433KV, 3PHASE, ALU WOUND CORE CORE, DIST TRANSFORMER |
| SCALE | ENERGY EFFICIENCY LEVEL-2 AS PER IS: 1180 (PART-1);2014 |
| | DRAWING NO:- MSEDCL/HVDS/16/11 3φ/EEL2/06 |

TRANSFORMER HV BUSHING ASSEMBLY DRAWING AS PER IS:3347

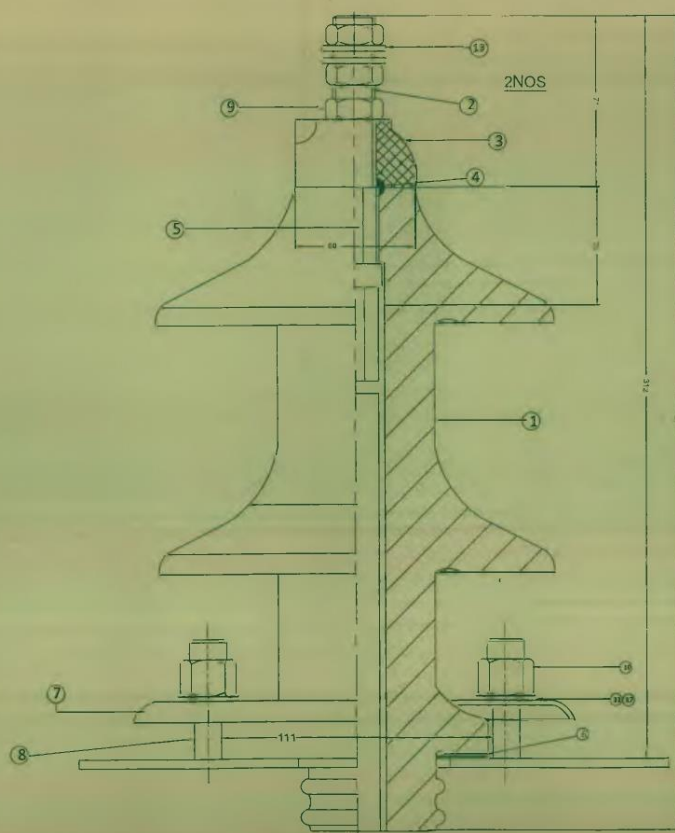

ALL DIMENSIONS ARE IN mm.

QUANTITY: NOS

ELECTRICAL CHARECTERISTICS:

1. RATED VOLTAGE 12KV
2. RATED CURRENT 250 Amp
3. POWER FREQUENCY WITHSTAND VOLTAGE: 28KV
4. IMPULSE WITHSTAND VOLTAGE 75 KVP
5. CREEPAGE DISTANCE: 305 mm.

NOTE:
 PERFORMANCE REQUIREMENTS OF THE BUSHING SHALL CONFIRM TO IS: 2099-1986
 NRBC= NITRILE RUBBER BONDED CORK.

MAKE: JAIPUR/ SAMPAT/ UDYOG CENTRE/TAYAL/C.JI/BIKANER/ SAMRAKSHANA/RR/TEK MEK/SHINE/JS GROUP/ RR.

| SR.NO. | DESCRIPTION | QUANTITY |
|--------|---------------------------------------|----------|
| 1 | INSULATOR 12KV, 250 AMP. | 1 |
| 2 | STEM- M12x1.75 (E TINNING) | 1 |
| 3 | END CAP (E.TINNING) | 1 |
| 4 | SEALING WASHER (STEM) | 1 |
| 5 | SEPARATOR | 1 |
| 6 | SEALING WASHER FOR GEN. PURPOSE | 1 |
| 7 | CLAMPING RING | 1 |
| 8 | CLAMPING MEMBER | 4 |
| 9 | HEX. NUT FOR STEM-M12x1.75(E.TINNING) | 3 |
| 10 | HEX. NUT- M10 (HDG) | 4 |
| 11 | PLAIN WASHER- M10 (HDG) | 4 |
| 12 | SPRING WASHER- M10 (HDG) | 4 |
| 13 | PLAIN WASHER- M12 (E.TINNING) | 2 |

SIGNATURE
 OF AUTHORIZED
 PERSON & STAMP
 OF THE FIRM

| | |
|---|--|
| CUSTOMER | MAHARASHTRA STATE ELECTRICITY DISTRIBUTION CO. LTD |
| DRN BY | HV BUSHING ASSEMBLY DRAWING |
| CHD BY | 15 KVA, 11/0 433KV, 3PHASE, ALU WOUND, CRGO CORE, DIST TRANSFORMER |
| SCALE | (ENERGY EFFICIENCY LEVEL- 2 , AS PER IS:1180 (PART-1):2014 |
| DRAWING NO.- MHEDCL/HVDS/16/11.36/EEL2/05 | |

250 GM. SILICA GEL BREATHER (POLYPROPYLENE BODY)

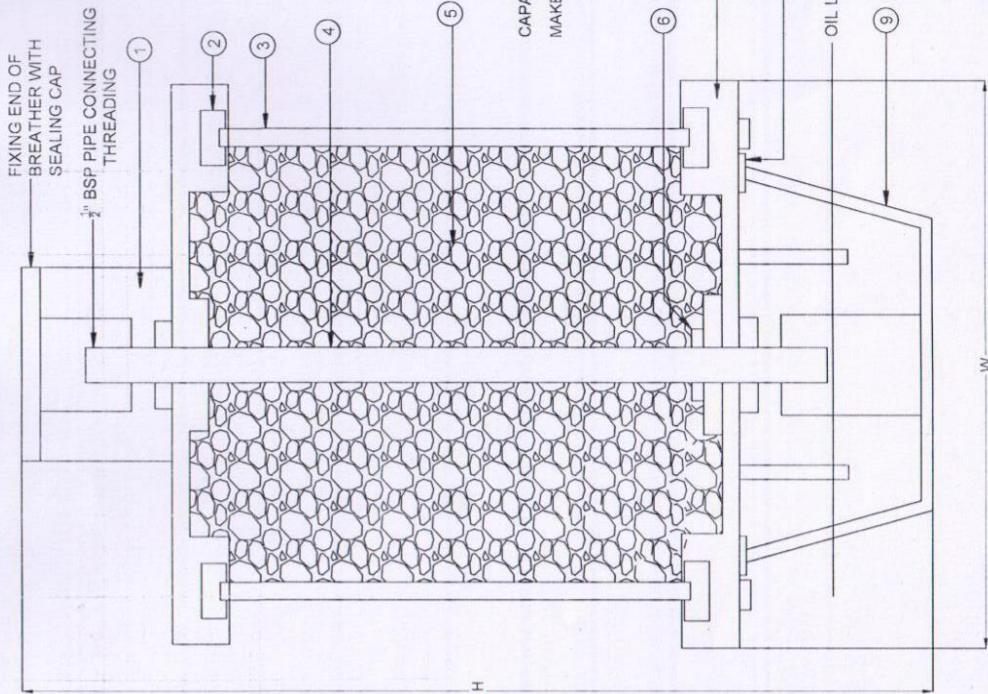

| S.R.NO. | DESCRIPTION | MATERIAL | QUANTITY |
|---------|-------------------|----------------|----------|
| 1. | TOP COVER | ALUMINIUM | 1. |
| 2. | U-GASKET | NITRILE RUBBER | 1. |
| 3. | TRANSPARENT TUBE | SAN | 1. |
| 4. | STUD | M.S. | 1. |
| 5. | SILICA JEL (BLUE) | SILICA JEL | 250 GMS |
| 6. | LOCK NUT | M.S. | 1. |
| 7. | BOTTOM COVER | ALUMINIUM | 1. |
| 8. | PLAIN GASKET | NITRILE RUBBER | 1. |
| 9. | OIL CUP | | 1. |

REMARKS:

FOLLOWING INSTRUCTIONS TO BE FOLLOWED BEFORE FIXING BREATHER

1. REMOVE THE SEALING CAP PROVIDED AT THE FIXING END OF BREATHER AND ALSO PVC PROVIDED AT THE END OF BREATHER FIXING PIPE ON CONSERVATOR.
2. FILL THE OIL IN THE TANK CAP TO THE LEVEL IS SHOWN IN THE DRAWING.

CAPACITY OF SILICA GEL: 250 gm.

MAKE: ELECTRICAL ENGINEERING SHIVANTS, (AT FORGING) RENU TRANSCO

QUANTITY: NOS

SIGNATURE
OF AUTHORIZED
PERSON & STAMP
OF THE FIRM

| | |
|---------------------------------|--|
| CUSTOMER | MAHARASHTRA STATE ELECTRICITY DISTRIBUTION CO. LTD. |
| DRN BY | SILICA GEL BREATHER 250GMS |
| CHD BY | 25 KVA, 110/23KV, 3PHASE, ALU WOUND, CRGO CORE, DIST TRANSFORMER |
| SCALE | (ENERGY EFFICIENCY LEVEL-2, AS PER IS:1180 PART-1/2014) |
| DRAWING NO.: 25/11 3G/EE/L2/09. | |

POWER A GUIDE

Total Losses at * :

50% loading - 135 Watts

100% loading - 440 Watts

| | |
|--------------|-------------------------------|
| Equipment | : Distribution Transformer |
| Type | : Oil Filled naturally cooled |
| Make | : |
| Model / year | : |
| Capacity | : 16 KVA |
| Voltage | : upto 11kv |

ENERGY IS LIFE

CONSERVE IT
BEE/MEE/03/0751/17

*Under test conditions, when tested in accordance with IS 1180 : 1989

NOTE:

- 1) THE UNIQUE LABEL SERIES CODE PROVIDED IN THE LETTER HAS TO BE MENTIONED IN THE LABEL AFFIXED ON THE DISTRIBUTION TRANSFORMER
- 2) THE LABEL DESIGN SIZE, COLOR SCHEME, MATERIAL TO BE USED FOR THE LABEL CONTENT OF THE LABEL AND COLOR SCHEME OF THE BUREAU'S LOGO SHALL BE AS SCHEDULED TO THE BUREAU OF ENERGY EFFICIENCY (PARTICULARS AND MANNER OF THEIR DISPLAY ON LABEL OF DISTRIBUTION TRANSFORMER) REGULATION 2009

QUANTITY: NOS

SIGNATURE
OF AUTHORIZED
PERSON & STAMP
OF THE FIRM

| | |
|----------|---|
| CUSTOMER | MAHARASHTRA STATE ELECTRICITY DISTRIBUTION CO.LTD |
| DRN BY | BEE 1 STAR LABEL DRAWING |
| CHD BY | 16 KVA 11KV 233KV, 3PHASE ALU WOUND, CRGO CORE DIST |
| SCALE | TRANSFORMER ENERGY EFFICIENCY LEVEL - 2, AS PER IS 1180 /PART-1/2014 |
| | DRAWING NO.- MSEDCL/HVDS/16/11 3φ/EEL2/09 |

| SR. NO. | ACCESSORIES. | QTY | DETAIL |
|---------|---|-----|-------------------|
| 1. | SEALING BOLT | 2 | M.S. |
| 2. | LIFTING LUGS FOR TOP COVER: 8MM | 3 | M.S. |
| 3. | LIGHTNING ARRESTORS | 3 | 9KV/5KA PORCELAIN |
| 4. | HV BUSHING 12 KV, 250 AMP | 3 | BRASS |
| 5. | HV TERMINAL WITH STUDS - M12 | 2 | M.S. |
| 6. | LIFTING LUGS 8 MM FOR TANK | 2 | M.S. |
| 7. | REINFORCING ANGLE (25X25X5 MM) | 1 | ANODIZED AL |
| 8. | RATING & DIAGRAM PLATE: RIVETED/SCREWED | 1 | T- VALVE |
| 9. | DRAIN VALVE (Ø2 MM) | 1 | M.S. |
| 10. | PULLING LUGS | 4 | M.S. |
| 11. | LV BUSHINGS 1KV/250 AMP | 4 | PORCELAIN |
| 12. | LV TERMINAL STUDS - M12 | 4 | BRASS |
| 13. | EARTHING TERMINAL 10 MM | 2 | M.S. |
| 14. | BASE CHANNEL- 75MMX40MM WITH HOLES | 2 | M.S. |
| 15. | THERMOMETER POCKET WITH CAP | 1 | M.S. |
| 16. | AIR RELEASE PLUG- 1/2" DIA | 1 | M.S. |
| 17. | TOP COVER FIXING BOLTS- 1/2" DIA WITH PLAIN WASHER | 2 | GI |
| 18. | OIL FILLING HOLE WITH CAP (GAUGE FOR TEST) | 1 | M.S. |
| 19. | OIL LEVEL INDICATOR (Ø5, 30, 90) | 1 | M.S. |
| 20. | SWITCH OFF FOR CABLE CLAMP | 1 | M.S. |
| 21. | 2 YEARS WARRANTY PLATE | 1 | M.S. |
| 22. | SEE LABEL | 1 | STRIKER |
| 23. | ANTI THEFT STAINLESS STEEL FASTENERS WITH BREAK AWAY AT TOP COVER | 4 | S.S |
| 24. | OR CODE LABEL | 1 | STRIKER |
| 25. | BEATHER PIPE | 1 | M.S. |
| 26. | CONSERVATOR TANK (SIZE D-175 X L-500 MM) | 1 | M.S. |
| 27. | SILICA GEL BREATHER 250GRMS | 1 | POLYPROPYLENE |

| RADIATING SURFACE AREA | TANK TOTAL | 1.553 Sq. METRS |
|------------------------|------------|-----------------|
| | | 1.553 Sq. METRS |

| WEIGHT IN KGS | | |
|---------------|-----------------|-----|
| 1. | CORE | 84 |
| 2. | WINDINGS | 360 |
| 3. | ASSEMBLY WEIGHT | 588 |
| 4. | TANK & FITTINGS | 95 |
| 5. | OIL in Kgs | 95 |
| 6. | TOTAL WEIGHT | 380 |

| DIMENSIONS ARE IN mm | | |
|----------------------|----------------|----------|
| L | OVERALL L TANK | 60 |
| W | W | 250 |
| H | H | 1300 |
| | | 785(Avg) |

| THICKNESS ARE IN mm | | |
|---------------------|--------------------|------|
| L3 (H.V) | 255 PHASE TO PHASE | 3.15 |
| L4 (L.V) | 75 PHASE TO PHASE | 5 |
| L5 (H.V) | 140 PHASE TO EARTH | |
| L6 (H.V) | 40 PHASE TO EARTH | |

| DIMENSION OF CONSERVATOR | | |
|--------------------------|--------------------|--------|
| | INSIDE DIAMETER(D) | 175mm |
| | LENGTH (L2) | 500 mm |
| | CAPACITY (TOTAL) | 12 LTR |

SIGNATURE OF AUTHORIZED PERSON & STAMP OF THE FIRM

| | |
|----------|--|
| CUSTOMER | MAHARASHTRA STATE ELECTRICITY DISTRIBUTION CO. LTD |
| DRN BY | GENERAL ARRANGEMENT DRAWING |
| CHD BY | 25 KVIA, 110/433KV, 3PHASE, ALU WOUND, CRGO CORE, DIST TRANSFORMER |
| SCALE | (ENERGY EFFICIENCY LEVEL-2, AS PER IS:1180 (PART-1):2014) |
| | DRAWING NO.- 25/11 3ø/EEL/2/02. |

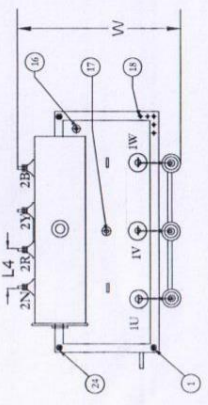
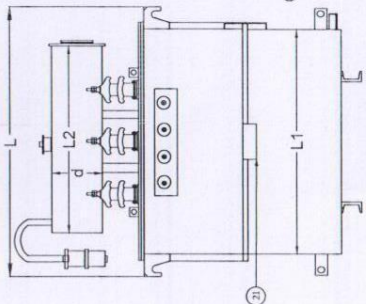
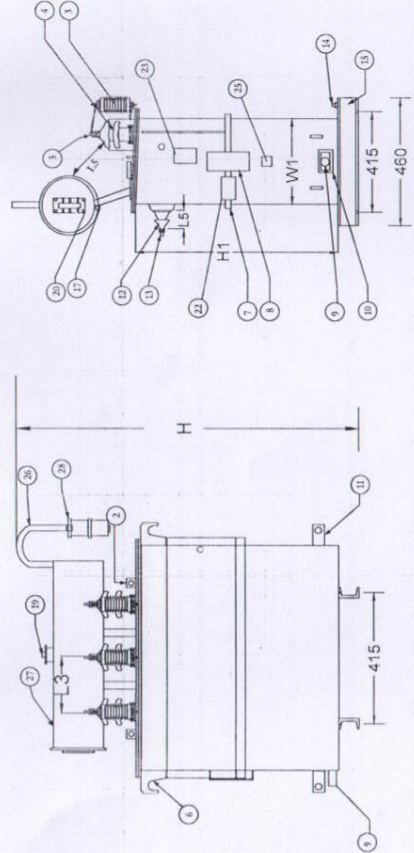

QUANTITY: NOS

NOTE:

1. WIDTH OF TOP COVER BEND PLATE - MIN. 25 mm.
2. COLOR OF TRANSFORMER:- AIRCRAFT BLUE SHED NO.108 OF IS. 5
- 3.GASKET BETWEEN TOP COVER & TANK SHALL BE AS PER IS. 4253
4. LIGHTNING ARRESTOR (AS PER IS: 3070/1974)
5. MAKE OF PRESS BOARD- RAMAN/JMANG/SENAPATHY/ITC / RAJ TECHNO / KUBERA INNOVATIVE.
6. ALL WELDING OPERATIONS SHALL BE CARRIED OUT BY MIG PROCESS.
7. TRANSFORMER TOP COVER SHALL BE SLOPING UPTO 5° TO 10° TOWARDS HV SIDE
- 8.WEIGHT ARE SUBJECT TO +.5% TOLERANCE.
9. MAKE OF BREATHER- ELECTRIC ENGINEERS/ RAJSHREE/ YASHWANT/ BHARAT FORGING/RENU TRANSOCO.

NOTE:-
 1) (*) MARKED VALUE WILL BE PUNCHED AT THE TIME OF DISPATCH.
 2) MATERIAL ALUMINIUM ANODIZED.
 3) THICKNESS -18 SWG-MIN.
 4) ALL DIMENSIONS ARE IN mm UNLESS OTHERWISE STATED.

Ø3.6mm
 165 175
 Ø3.6mm



For Detail Of the BIS Certification Marks Scheme Refer : www.bis.org.in
 3 PHASE WOUND DISTRIBUTION TRANSFORMER
 STANDARD IS:1180 (PART-1) 2014

| | | | |
|---------------------------------|---|--|------|
| KVA | 25 | ENERGY EFFICIENCY LEVEL | 2 |
| VOLTS AT HV | 11000 | MAX. TOTAL LOSSES AT 50% RATED LOAD AT 75°C | 190 |
| NO LOAD | 433 | MAX. TOTAL LOSSES AT 100% RATED LOAD AT 75°C | 635 |
| BIL (KVP) | 75 | TEMP. RISE OVER OIL AMBIENT 50°C. | 35° |
| AMPERES HV | 1.31 | WDG | 40° |
| LV | 33.33 | MASS OF OIL (Kgs) | 95 |
| FREQUENCY Hz | 50 | TOTAL WEIGHT (Kgs) | 360 |
| VECTOR GROUP | Dyn-11 | VOLUME OF OIL(Ltrs) | 115 |
| IMPEDANCE VOLT. % | * | TYPE OF COOLING | ONAN |
| MONTH & YEAR OF G.P. COMPLETION | | MONTH & YEAR OF MFG | * |
| SERIAL NO. | * | MONTH & YEAR OF G.P. COMPLETION | |
| CUSTOMER | MAHARASHTRA STATE ELECTRICITY DISTRIBUTION CO. LTD. | | |
| ORDER NO. | | | |

MADE IN INDIA

TERMINAL MARKING & DIAGRAM

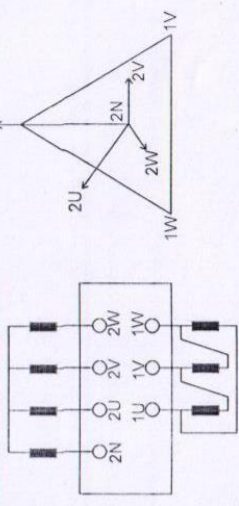

95
105

QUANTITY: NOS

SIGNATURE
 OF AUTHORIZED
 PERSON & STAMP
 OF THE FIRM

| | |
|----------|---|
| CUSTOMER | MAHARASHTRA STATE ELECTRICITY DISTRIBUTION CO. LTD |
| DRN BY | RATING & DIAGRAM DRAWING. |
| CHD BY | 25 KVA, 110/433KV, 3PHASE, ALU WOUND, CRGO CORE, DIST TRANSFORMER |
| SCALE | ENERGY EFFICIENCY LEVEL: 2, AS PER IS:1180 (PART-1) 2014 |
| | DRAWING NO:- 25/11 3φ/EEL2/01. |

| SR. NO. | DESCRIPTION | TECHNICAL DETAILS AS PER OFFER |
|---------|---|--------------------------------|
| 1. | PRIMARY VOLTAGE (KV) | 11 KV |
| 2. | SECONDARY VOLTAGE (KV) | 0.433 KV |
| 3. | RATING (KVA) | 25 KVA |
| 4. | VECTOR GROUP | Dry, 11 |
| 5. | CONFORMING TO I.S.S. | IS: 1180 & PART-1 2014 |
| 6. | PERMISSIBLE VOLTAGE FLUCTUATION % | 12.5% |
| 7. | TEMPERATURE RISE OF OIL OVER AMBIENT 60°C | 35 |
| 8. | TEMPERATURE RISE OF WINDING OVER AMBIENT 60°C | 40 |
| 9. | THICKNESS OF CORE LAMINATION | 0.27 mm |
| a) | CORE MATERIAL | CRGO ANNEALED STEEL |
| b) | PRINCIPLE SOURCE OF CORE MATERIAL | IMPORTED |
| c) | GRADE OF LAMINATION | M4 |
| d) | FLUX DENSITY W/m^2 | 1.69 Max. |
| e) | NO. OF STEPS OF CORE (NOS.) | 7 |
| 10. | % IMPEDANCE | 4.5% (±10%) |
| 11. | CORE DIMENSIONS (L x W x Cd) | 235X455X81 |

| STEP NO. | 1. | 2. | 3. | 4. | 5. | 6. | 7. |
|----------------------|--------|------|------|------|------|------|------|
| L mm. | 75 | 70 | 65 | 60 | 50 | 40 | 30 |
| W mm. | 30.2 | 19.7 | 7.6 | 6.5 | 9.7 | 6.5 | 4.3 |
| CROSS SECTION Cm^2 | 22.656 | 7.9 | 4.94 | 3.90 | 4.85 | 2.60 | 1.29 |

TOTAL CROSS SECTION AREA Cm^2 = 47.02

EFFECTIVE CORE AREA = 47.02X 0.97 = 45.609 Cm^2

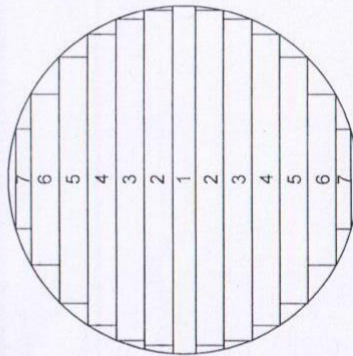

QUANTITY: NOS

| SR. NO. | DESCRIPTION | AS PER OFFERED |
|---------|-----------------------------------|----------------|
| 12. | WINDING | H.V. L.V. |
| a) | MATERIAL | ALU |
| b) | SPECIFIC CONDUCTIVITY | - |
| c) | CONDUCTOR SIZE IN mm | 1.18 |
| d) | CONDUCTOR CROSS SECTION mm^2 | 1.09 |
| e) | INSULATION MATERIAL | DPC |
| f) | CURRENT DENSITY A/mm^2 Max | 1.3 |
| g) | NO. OF TURNS | 7216 |
| h) | OUTER DIAMETER mm | 225 |
| i) | INSIDE DIAMETER mm | 139.5 |
| j) | AXIAL LENGTH mm | 97 PER COIL |
| k) | NO. OF COIL PER PHASE NO. | 4 |
| l) | RESISTANCE PER PHASE Ohms at 75°C | 111 |

| 13. | BUSHING | AS PER OFFERED |
|-----|---|--|
| | MINIMUM CREEPAGE DISTANCE IN MM | HV 305 mm LV 65 mm |
| 14. | LOSSES | |
| | NO LOAD LOSS | 85 WATTS |
| | TOTAL LOSSES AT 75°C AT 50% LOAD (Watts) | 190 (MAX) |
| | TOTAL LOSSES AT 75°C AT 100% LOAD (Watts) | 635 (MAX) |
| 15. | TANK | |
| | SIDE WALL THICKNESS mm.(MIN) | 3.15 |
| | TOP & BOTTOM PLATE THICKNESS mm.(MIN) | 5 |
| 16. | OIL USED | |
| | NAME OF MANUFACTURER | |
| | GRADE | MINERAL OIL CONFORMING TO IS 305 AMENDED UP TO DATED |
| | VOLUME (LITRE'S) | --- |
| | IN TANK | 110 |
| | CONSERVATOR | 5.5 |
| | TOTAL | 115 |

SIGNATURE OF AUTHORIZED PERSON & STAMP OF THE FIRM

| | |
|----------|--|
| CUSTOMER | MAHARASHTRA STATE ELECTRICITY DISTRIBUTION CO. LTD |
| DRN BY | TECHNICAL SPECIFICATION DRAWING |
| CHD BY | 25 KVA, 11/0.433KV, 3PHASE, ALU WOUND, CRGO CORE, DIST TRANSFORMER |
| SCALE | (ENERGY EFFICIENCY LEVEL-2, AS PER IS:1180 (PART-1):2014) |
| | DRAWING NO:- 25/11 3φ/EELZ/04. |

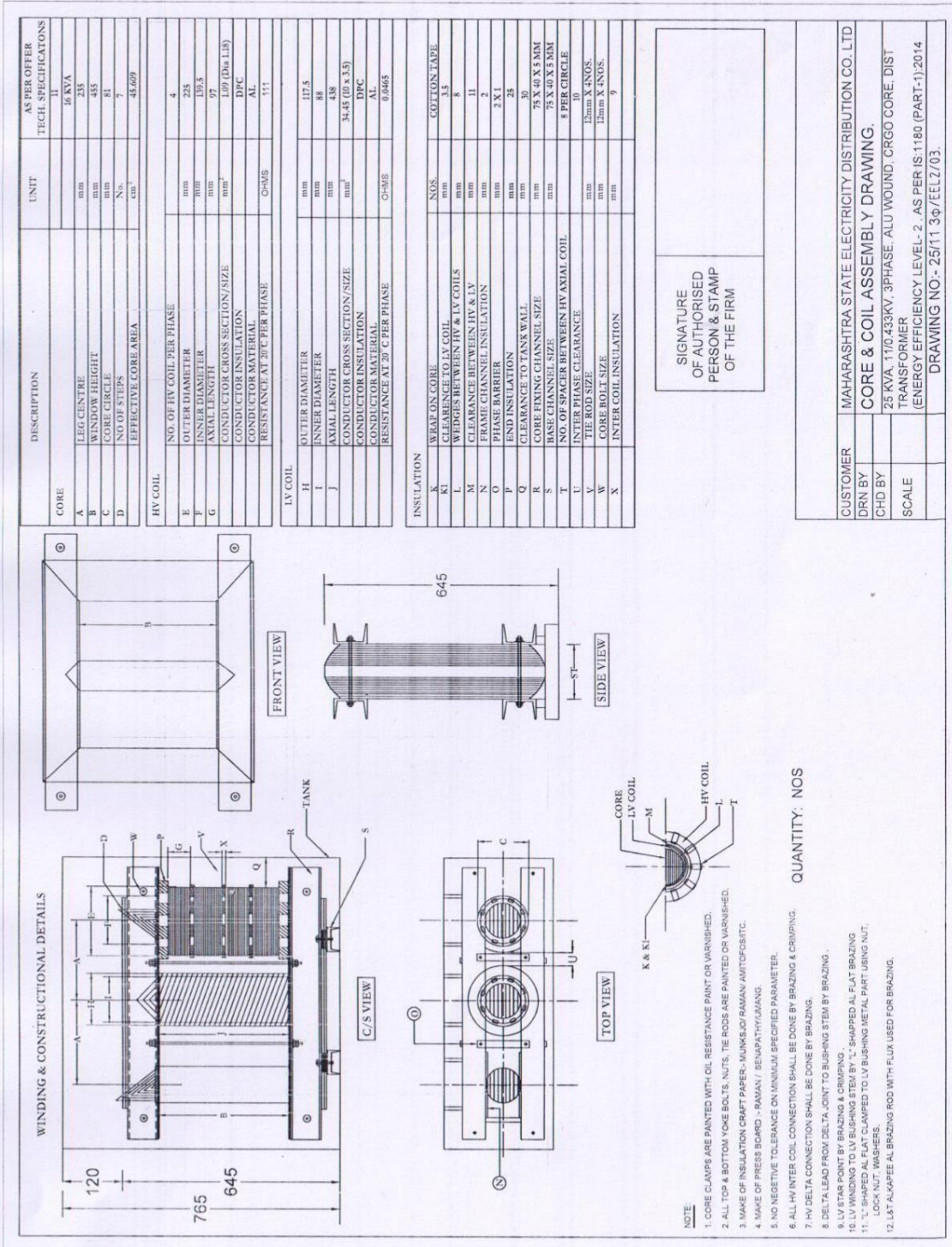

TRANSFORMER HV BUSHING ASSEMBLY DRAWING AS PER IS:3347

ELECTRICAL CHARACTERISTICS:

1. RATED VOLTAGE : 12KV
2. RATED CURRENT: 250 Amp
3. POWER FREQUENCY WITHSTAND VOLTAGE: 28KV
4. IMPULSE WITHSTAND VOLTAGE 75 KVP
5. CREEPAGE DISTANCE: 305 mm.

NOTE:
 PERFORMANCE REQUIREMENTS OF THE BUSHING SHALL CONFIRM TO IS: 2099-1986
 NRBC= NITRILE RUBBER BONDED CORK

MAKE: **SIEMENS** GROUP.

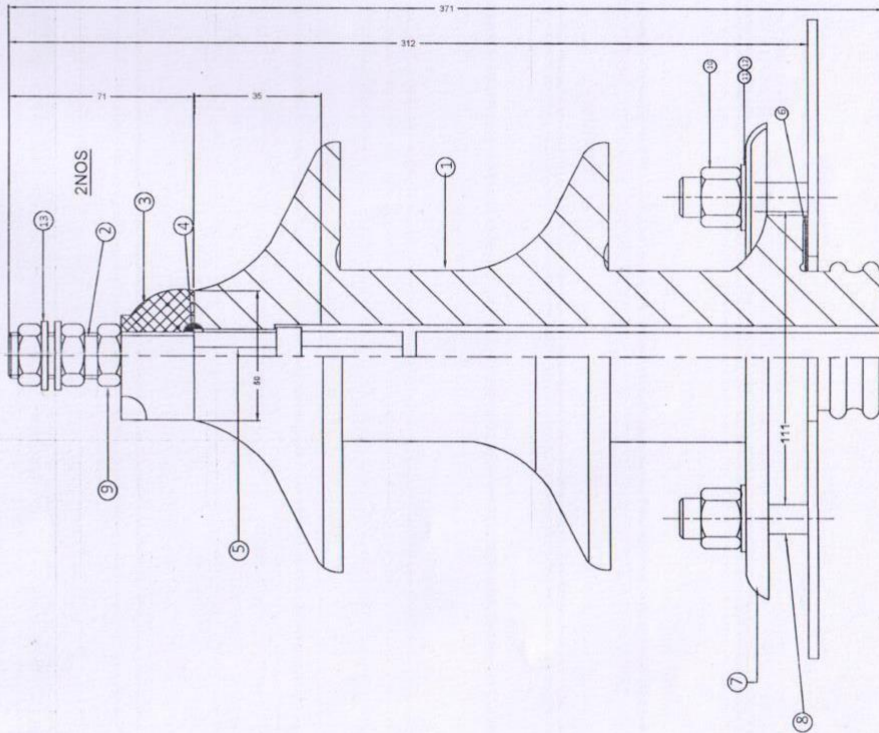

ALL DIMENSIONS ARE IN mm.

QUANTITY: NOS

| SR.NO. | DESCRIPTION | QUANTITY |
|--------|---------------------------------------|----------|
| 1. | INSULATOR 12KV, 250 AMP. | 1 |
| 2. | STEM- M12x1.75 (E.TINNING) | 1 |
| 3. | END CAP (E.TINNING) | 1 |
| 4. | SEALING WASHER (STEM) | 1 |
| 5. | SEPARATOR | 1 |
| 6. | SEALING WASHER FOR GEN. PURPOSE | 1 |
| 7. | CLAMPING RING | 1 |
| 8. | CLAMPING MEMBER | 4 |
| 9. | HEX. NUT FOR STEM-M12x1.75(E.TINNING) | 3 |
| 10. | HEX. NUT- M10 (HDG) | 4 |
| 11. | PLAIN WASHER- M10 (HDG) | 4 |
| 12. | SPRING WASHER- M10 (HDG) | 4 |
| 13. | PLAIN WASHER- M12 (E.TINNING) | 2 |

SIGNATURE
 OF AUTHORIZED
 PERSON & STAMP
 OF THE FIRM

| | |
|----------|---|
| CUSTOMER | MAHARASHTRA STATE ELECTRICITY DISTRIBUTION CO. LTD |
| DRN BY | HV BUSHING ASSEMBLY DRAWING 12 KV/250A |
| CHD BY | 25 KVA, 110, 433KV, 3PHASE, ALU WOUND, CRGO CORE, DIST |
| SCALE | TRANSFORMER (ENERGY EFFICIENCY LEVEL-2 ,AS PER IS:1180 (PART-1):2014 |
| | DRAWING NO.- 25/11 3p/EELZ/05. |

NOTE:
 1. DIMENSIONS ARE CONFORMING TO IS: 3347 (PART-III/SEC.1)- 1988.
 2. COLOUR: DARKEN BROWN
 3. CREEPAGE DISTANCE: 305mm. (MIN.)

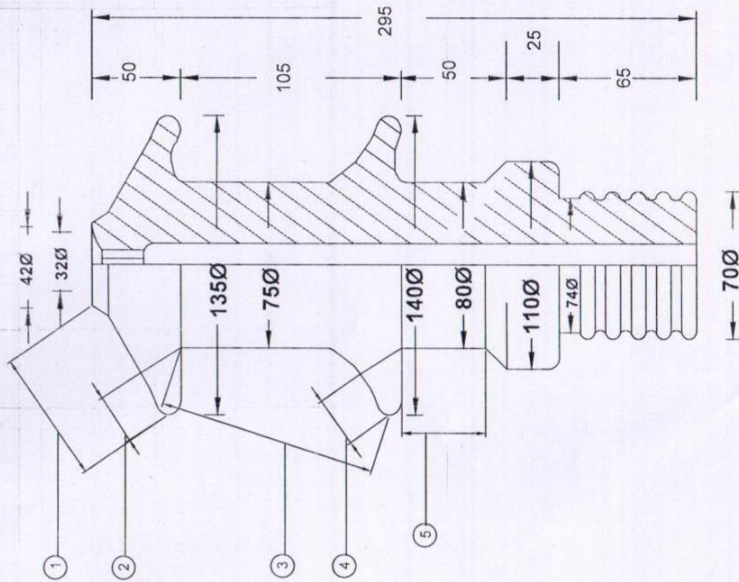

ALL DIMENSIONS ARE IN mm.

| | |
|--|--------------------------|
| RATED RATING | 12 KV/250A |
| STANDARD APPLICABLES IS | IS- 3347 (PART-III)/2009 |
| ONE MINUTE DRY P.F. VOLTAGE WITHSTAND | 28 KV (RMS) |
| ONE MINUTE WET P.F. VOLTAGE WITHSTAND | 28 KV (RMS) |
| 1.2/50 MICRO. SEC. IMPULSE VOLTAGE WITHSTAND | 75 KVP |
| WEIGHT OF ASSEMBLED BUSHING | 3.54 Kg |
| TOTAL CREEPAGE DISTANCE (AIR) 25mm/kv | 305 mm. |

| CREEPAGE DISTANCE POINT NO. | DIMENSIONS |
|-----------------------------|------------|
| 1 | 79 |
| 2 | 30 |
| 3 | 80 |
| 4 | 43 |
| 5 | 30 |
| 6 | 43 |
| TOTAL | 305 mm |

SIGNATURE
 OF AUTHORIZED
 PERSON & STAMP
 OF THE FIRM

QUANTITY: NOS

| | |
|----------|---|
| CUSTOMER | MAHARASHTRA STATE ELECTRICITY DISTRIBUTION CO.LTD |
| DRN BY | CREEPAGE DISTANCE DRAWING OF HV BUSHING 12KV/250 |
| CHD BY | Amps |
| SCALE | 25 KV/A: 110/433KV, 3PHASE, ALU WOUND, CRGO CORE, DIST TRANSFORMER (ENERGY EFFICIENCY LEVEL-2, AS PER IS:1180 (PART-1):2014 |
| | DRAWING NO.- 25/11_3ø/EEL/2/06. |

TRANSFORMER LV BUSHING ASSEMBLY DRAWING AS PER IS: 3347

ELECTRICAL CHARECTERISTICS:

1. RATED VOLTAGE : 1KV
2. RATED CURRENT: 250 Amp
3. POWER FREQUENCY WITHSTAND VOLTAGE: 3KV
4. CREEPAGE DISTANCE: 65 mm.

NOTE:

PERFORMANCE REQUIREMENTS OF THE BUSHING SHALL CONFIRM TO IS: 7421- 1988

MAKE: SHINJI

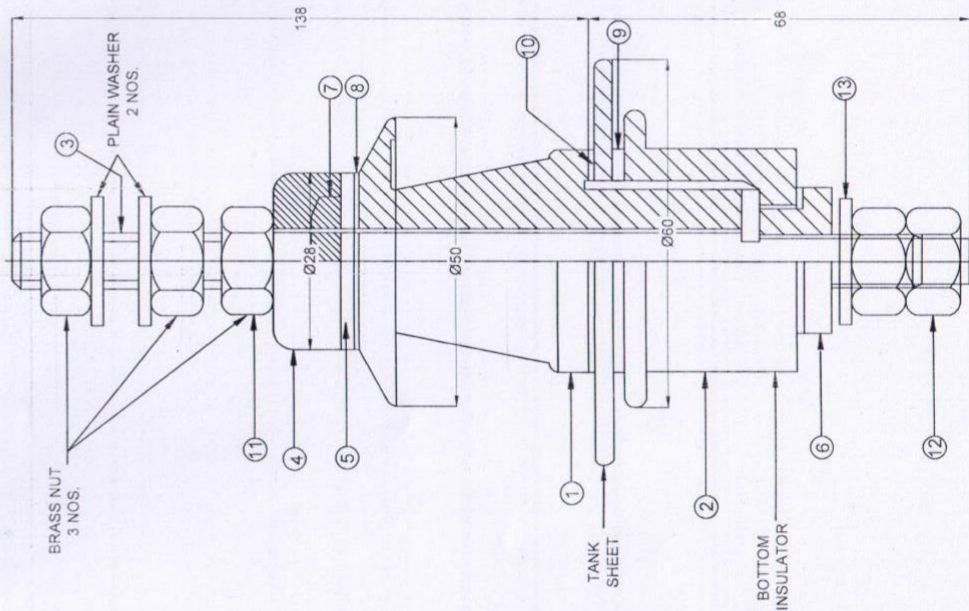

| SR.NO. | DESCRIPTION | MATERIAL | QUANTITY |
|--------|-------------------------------|------------------|----------|
| 1. | UPPER INSULATOR | PORCELAIN | 1 |
| 2. | LOWER INSULATOR | PORCELAIN | 1 |
| 3. | STEM- (M12x1.75) (E. TINNING) | BRASS | 1 |
| 4. | TOP END WASHER (E. TINNING) | BRASS | 1 |
| 5. | STEM WASHER (E. TINNING) | BRASS | 1 |
| 6. | BOTTOM NUT (E. TINNING) | BRASS | 1 |
| 7. | SEALING WASHER (STEM) | SYNTHETIC RUBBER | 1 |
| 8. | SEALING GASKET WASHER | NRBC | 1 |
| 9. | SEALING GASKET WASHER | NRBC | 1 |
| 10. | SEALING GASKET WASHER | NRBC | 1 |
| 11. | HEXAGONAL NUT M-12 | BRASS | 3 |
| 12. | HEXAGONAL LOCKING NUT M-12 | BRASS | 2 |
| 13. | PLAIN WASHER (TYPE-N) | BRASS | 3 |

QUANTITY: NOS

SIGNATURE
OF AUTHORIZED
PERSON & STAMP
OF THE FIRM

| | |
|----------|--|
| CUSTOMER | MAHARASHTRA STATE ELECTRICITY DISTRIBUTION CO.LTD |
| DRN BY | LV BUSHING ASSEMBLY DRAWING |
| CHD BY | 25 KVA, 11/0.433KV, 3PHASE, ALU WOUND, CRGO CORE, DIST TRANSFORMER |
| SCALE | (ENERGY EFFICIENCY LEVEL-2, AS PER IS:1186) (PART-1) 2014 |
| | DRAWING NO. - 25/11 3φ/EEL2/07. |

CREEPAGE DISTANCE DRAWING OF LV BUSHING 1.0KV/250 Amps.

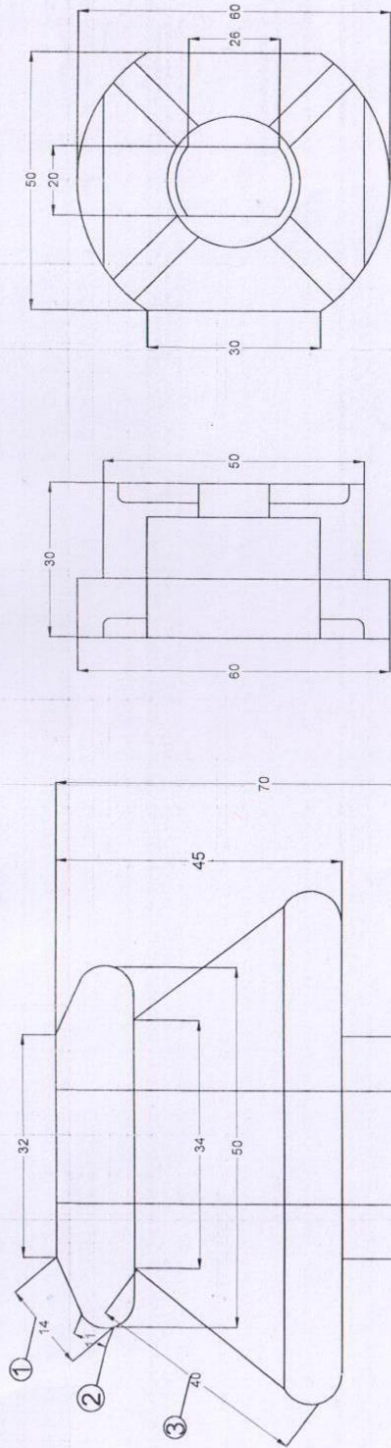

LOWER INSULATOR

| POINT NO. | DIMENSIONS |
|-----------|------------|
| 1 | 14 |
| 2 | 11 |
| 3 | 40 |
| TOTAL | 65 mm |

UPPER INSULATOR

QUANTITY: NOS

SIGNATURE
OF AUTHORIZED
PERSON & STAMP
OF THE FIRM

- NOTE:**
- COLOR- BROWN GLAZED
 - CREEPAGE DISTANCE -25mm/KV(Min.)
 - AS PER IS:3347 (PART-I/SECI)
 - ALL DIMENSIONS IN mm.
 - RATED VOLTAGE- 1.0 KV
 - RATED CURRENT- 250 AMP.
 - WEIGHT OF BUSHING ASSEMBLY- 0.7Kg. (APPROX.)
 - PERFORMANCE REQUIRMENTS OF THE BUSHING SHALL CONFORM TO IS: 2099-1996
 - TOTAL CREEEPAGE DISTANCE- 65mm.
 - ALL DIMENSIONS ARE IN mm.

| | |
|----------|--|
| CUSTOMER | MAHARASHTRA STATE ELECTRICITY DISTRIBUTION COLTD |
| DRN BY | CREEPAGE DISTANCE DRAWING OF |
| CHD BY | LV BUSHING 1.0KV/250 AMPS |
| SCALE | 25 KVA, 110.433KV, 3PHASE, ALU WOUND, CRGO CORE 'DST' (ENERGY EFFICIENCY LEVEL-2, AS PER IS: 1180 (PART-1):2014 |
| | DRAWING NO.- 25/11, 3/4/EEEL7/08 |

250 GM. SILICA GEL BREATHER (POLYPROPYLENE BODY)

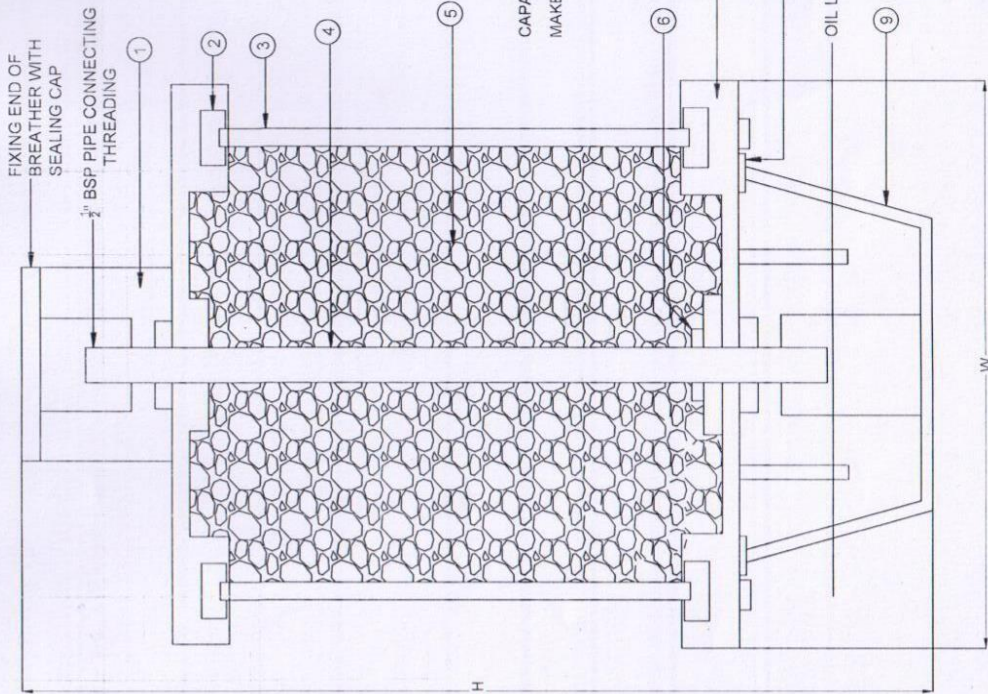

| S.R.NO. | DESCRIPTION | MATERIAL | QUANTITY |
|---------|-------------------|----------------|----------|
| 1. | TOP COVER | ALUMINIUM | 1. |
| 2. | U-GASKET | NITRILE RUBBER | 1. |
| 3. | TRANSPARENT TUBE | SAN | 1. |
| 4. | STUD | M.S. | 1. |
| 5. | SILICA JEL (BLUE) | SILICA JEL | 250 GMS |
| 6. | LOCK NUT | M.S. | 1. |
| 7. | BOTTOM COVER | ALUMINIUM | 1. |
| 8. | PLAIN GASKET | NITRILE RUBBER | 1. |
| 9. | OIL CUP | | 1. |

REMARKS:

FOLLOWING INSTRUCTIONS TO BE FOLLOWED BEFORE FIXING BREATHER

1. REMOVE THE SEALING CAP PROVIDED AT THE FIXING END OF BREATHER AND ALSO PVC PROVIDED AT THE END OF BREATHER FIXING PIPE ON CONSERVATOR.
2. FILL THE OIL IN THE TANK CAP TO THE LEVEL IS SHOWN IN THE DRAWING.

CAPACITY OF SILICA GEL: 250 gm.

MAKE: ELECTRICAL ENGINEERING SHIVANTER, (AT FORGING) RENU TRANSCO

QUANTITY: NOS

SIGNATURE
OF AUTHORIZED
PERSON & STAMP
OF THE FIRM

| | |
|----------|---|
| CUSTOMER | MAHARASHTRA STATE ELECTRICITY DISTRIBUTION CO. LTD. |
| DRN BY | SILICA GEL BREATHER 250GMS |
| CHD BY | 25 KVA, 110/233KV, 3PHASE, ALU WOUND, CRGO CORE, DIST TRANSFORMER |
| SCALE | (ENERGY EFFICIENCY LEVEL-2, AS PER IS:1180 PART-1/2014) |
| | DRAWING NO.: 25/11 3G/EE/L2/09 |



Total Losses at * :
50% loading - 190 Watts
100% loading - 635 Watts

Equipment : Distribution Transformer
 Type : Oil Filled naturally cooled
 Make :
 Model / year :
 Capacity : 25KVA
 Voltage : upto 11kv

ENERGY IS LIFE



*Under test conditions, when tested in accordance with IS 1180 : 1989

NOTE:

- 1) THE UNIQUE LABEL SERIES CODE PROVIDED IN THE LATTER HAS TO BE MENTIONED IN THE LABEL AFFIXED ON THE DISTRIBUTION TRANSFORMER
- 2) THE LABEL DESIGN SIZE, COLOR SCHEME , MATERIAL TO BE USED FOR THE LABEL CONTENT OF THE LABEL AND COLOR SCHEME OF THE BUREUS LOGO SHALL BE AS SCHEDULED TO THE BUREAU OF ENERGY EFFICIENCY (PARTICULARS AND MANNER OF THEIR DISPLAY ON LABEL OF DISTRIBUTION TRANSFORMER) REGULATION 2009

QUANTITY: NOS

SIGNATURE
 OF AUTHORIZED
 PERSON & STAMP
 OF THE FIRM

| | |
|----------|---|
| CUSTOMER | MAHARASHTRA STATE ELECTRICITY DISTRIBUTION CO.LTD |
| DRN BY | BEE 1 STAR LABEL DRAWING |
| CHD BY | 25-KVA, 1100-433KV, 3PHASE, ALU WOUND, CRGO CORE, DIST |
| SCALE | (ENERGY EFFICIENCY LEVEL-2, AS PER IS:1180 (PART-1)2014 |
| | DRAWING NO:- 25/11 3ø/EEEL 2/10. |

25KVA11/0.433KV3PHDISTTRANFSTAR1/EEL-1

| GTP Order Sequence | GTP Parameters | Date Type |
|--------------------|--|-----------|
| 1 | Name of Manufacturer | TEXT |
| 2 | Reference Standard | TEXT |
| 3 | Whether transformer is Oil Natural Air Natural cooled type (Yes/ No) | BOOLEAN |
| 4 | Whether transformer is suitable for Indoor /Outdoor installation | TEXT |
| 5 | Rating of transformer in KVA | TEXT |
| 6 | Primary Voltage in kV | TEXT |
| 7 | Secondary Voltage in kV | TEXT |
| 8 | Whether neutral earthed (Yes/ No) is solidly | TEXT |
| 9 | Colour of transformer | TEXT |
| 10 | Vector Group | TEXT |
| 11 | Approximate overall length of transformer in mm | TEXT |
| 12 | Approximate overall breadth of transformer in mm | TEXT |
| 13 | Approximate overall height of transformer in mm | TEXT |
| 14 | Approximate length of transformer tank in mm | TEXT |
| 15 | Approximate breadth of transformer tank in mm | TEXT |
| 16 | Approximate height of transformer tank in mm | TEXT |
| 17 | Thickness of the side of transformer Tank plate in mm | TEXT |
| 18 | Thickness of the bottom of transformer tank plate in mm | TEXT |
| 19 | Thickness of the top of transformer tank plate in mm | TEXT |
| 20 | Weight of Tank & fittings in kgs | TEXT |
| 21 | Total Weight of Transformer in kgs | TEXT |
| 22 | Type of Tank (corrugated/conventional) | TEXT |
| 23 | Degree of slope to the top plate of Transformer. | TEXT |
| 24 | In case of Corrugated tank, Thickness of corrugated sheet (in mm) | TEXT |
| 25 | Name plate details are as per the requirement specified in tender. (Yes/ No) | BOOLEAN |
| 26 | Total radiating surface of transformer tank in Sq. mtrs. | TEXT |
| 27 | Core material used & its grade | TEXT |
| 28 | Type of core | TEXT |
| 29 | Weight of Core in kgs | TEXT |
| 30 | No. of steps of core for CRGO core | TEXT |
| 31 | Diameter of core in mm | TEXT |

| | | |
|----|--|---------|
| 32 | Effective core area.(sq.cm) | TEXT |
| 33 | Flux density in Tesla | TEXT |
| 34 | Thickness of core lamination in mm | TEXT |
| 35 | The temperature shall in no case reach a value that will damage the core itself, other parts or adjacent materials (Yes/No) | BOOLEAN |
| 36 | Type of connection for H.V. Winding (Delta) (Yes/ No) | BOOLEAN |
| 37 | Type of connection for L.V. Winding (Star) (Yes/ No) | BOOLEAN |
| 38 | Material of H.V. winding | TEXT |
| 39 | Material of L.V.Winding | TEXT |
| 40 | Insulation winding. provided to H.V | TEXT |
| 41 | Insulation winding. provided to L.V. | TEXT |
| 42 | Current density of H.V. winding (in Ampere/ sq.mm) | TEXT |
| 43 | No of LV winding turns | TEXT |
| 44 | No of HV winding turns | TEXT |
| 45 | Resistance of LV winding per phase at 20 deg C in ohms | TEXT |
| 46 | Resistance of HV winding per phase at 20 deg C in ohms | TEXT |
| 47 | Current density of L.V. winding (in Ampere/sq. mm.) | TEXT |
| 48 | Clearance between Core & L.V. winding in mm | TEXT |
| 49 | Clearances between L.V. & H.V. winding in mm | TEXT |
| 50 | Clearances between HV Phase to Phase in mm | TEXT |
| 51 | Clearances between end insulation to Earth in mm end | TEXT |
| 52 | Clearances between winding to tank in mm (min 30 mm)Yes/No | BOOLEAN |
| 53 | Weight of Aluminum/Copper in kgs | TEXT |
| 54 | Inter layer insulation provided in H.V winding to design for Top & bottom layer | TEXT |
| 55 | Inter layer insulation provided in L.V winding to design for Top & bottom layer | TEXT |
| 56 | Inter layer insulation provided in between all layer in H.V winding | TEXT |
| 57 | Inter layer insulation provided in between all layer in L.V winding | TEXT |
| 58 | Details of end insulation | TEXT |
| 59 | Whether wedges are Provided at 50% turns of the Coil (Yes/ No) | BOOLEAN |
| 60 | Insulation materials provided for core | TEXT |
| 61 | Length of coil used winding in meter. for HV | TEXT |
| 62 | Cross section area of the coil used for HV winding (sq.mm) | TEXT |
| 63 | Length of coil used winding in meter. for LV | TEXT |
| 64 | Size of strip used for LV winding in mm | TEXT |
| 65 | No. of conductors in parallel for LV winding | TEXT |
| 66 | Total cross section area of LV conductor in sq. mm | TEXT |

| | | |
|-----|--|---------|
| 67 | No. of H.V coils /phase | TEXT |
| 68 | Thickness of locking spacers between H.V. coils (in mm) | TEXT |
| 69 | Weight of Oil in kgs | TEXT |
| 70 | Volume of Oil in Ltrs | TEXT |
| 71 | Quantity of total oil absorption (in liters) in first filling | TEXT |
| 72 | Total oil Volume including Total Oil absorption in liters | TEXT |
| 73 | Grade of Oil used | TEXT |
| 74 | Name of Oil manufacturers to be supplied. | TEXT |
| 75 | Breakdown Values of Oil at the time of first filling (kV/mm) considering 2.5 mm gap | TEXT |
| 76 | Conservator with Oil level indicator (showing three levels) (Yes/ No) | TEXT |
| 77 | Conservator tank to the Transformer with oil level indicator | TEXT |
| 78 | Drain Valve (32 mm) provided to the transformer tank (Yes/No) | TEXT |
| 79 | Earthing terminals with lugs is provided (Yes/No) | TEXT |
| 80 | Oil filling hole with cap (On conservator) | TEXT |
| 81 | Lifting lugs provided (Yes/No) | BOOLEAN |
| 82 | Thermometer pocket is provided (Yes/No) | BOOLEAN |
| 83 | Quantity of silica gel filled in breather | TEXT |
| 84 | Material of HV and LV Bushings and makes thereof | TEXT |
| 85 | Reference standard of Bushings | TEXT |
| 86 | Rating of L.V. Bushing | TEXT |
| 87 | Minimum Creepage Distance of HV Bushing in mm (min.25 mm per kV) | TEXT |
| 88 | Minimum Creepage Distance of LV Bushing in mm (min.25 mm per kV) | TEXT |
| 89 | Rating of H.V. Bushings (in kV) | TEXT |
| 90 | Rating of L.V. Bushing (in kV, kA) | TEXT |
| 91 | Min. External clearances of H.V. bushing terminals between ph. to ph (255 mm) | TEXT |
| 92 | Min. External clearances of H.V. bushing terminals between ph. to earth (140 mm) | TEXT |
| 93 | Min. External clearances of L.V. bushing terminals between ph. to ph (75 mm) | TEXT |
| 94 | Min. External clearances of L.V. bushing terminals between ph. to earth (40 mm) | TEXT |
| 95 | Rating of Lightning Arrestors and Make thereof | TEXT |
| 96 | Reference Standard of Lightning Arrestors. | TEXT |
| 97 | Maximum winding temperature rise in °C over an Ambient temp. of 50°C by Resistance Method | TEXT |
| 98 | Maximum temperature rise of Oil in °C over an Ambient temp. of 50°C by thermometer. | TEXT |
| 99 | Magnetizing current (No load) in Amps and its % of full load current at rated voltage referred to L.V. side. | TEXT |
| 100 | Magnetizing current (No load) in Amps and its % of full load current at maximum voltage (112.5% of rated voltage) referred to L.V. side. | TEXT |

| | | |
|-----|---|---------|
| 101 | Max. core (No load) losses at rated voltage and rated frequency (Watts) . | TEXT |
| 102 | Max. Total losses (No Load + Load Losses at 75 °C) at 50% loading in Watts | TEXT |
| 103 | Max. Total losses (No Load + Load Losses at 75 °C) at 100% loading in Watts | TEXT |
| 104 | Efficiency at 75 °C at unity P.F. at 125% load | TEXT |
| 105 | Efficiency at 75 °C at unity P.F. at 100% load | TEXT |
| 106 | Efficiency at 75 °C at unity P.F. at 75 % load | TEXT |
| 107 | Efficiency at 75 °C at unity P.F. at 50% load | TEXT |
| 108 | Efficiency at 75 °C at unity P.F. at 25% load | TEXT |
| 109 | Efficiency at 75 °C at 0.8 P.F. lag at 125% load | TEXT |
| 110 | Efficiency at 75 °C at 0.8 P.F. lag at 100 % load | TEXT |
| 111 | Efficiency at 75 °C at 0.8 P.F. lag at 75 % load | TEXT |
| 112 | Efficiency at 75 °C at 0.8 P.F. lag at 50 % load | TEXT |
| 113 | Efficiency at 75 °C at 0.8 P.F. lag at 25% load | TEXT |
| 114 | Efficiency at 75 °C at 0.8 P.F. leading at 125% load | TEXT |
| 115 | Efficiency at 75 °C at 0.8 P.F. leading at 100% load | TEXT |
| 116 | Efficiency at 75 °C at 0.8 P.F. leading at 75% load | TEXT |
| 117 | Efficiency at 75 °C at 0.8 P.F. leading at 50%load | TEXT |
| 118 | Efficiency at 75°C at 0.8 P.F. leading at 25 % load | TEXT |
| 119 | Regulation at Unity P.F (in %) | TEXT |
| 120 | Regulation at 0.8 P.F. lag. (in %) | TEXT |
| 121 | Regulation at 0.8 P.F. leading. (in %) | TEXT |
| 122 | % Impedance value at 75°C | TEXT |
| 123 | Separate source power frequency withstand test for HV for 1 minute in kv(min) | TEXT |
| 124 | Separate source power frequency withstand test for LV for 1 minute in kv(min) | TEXT |
| 125 | Induced over voltage withstand test for 1 min. specify voltage frequency, time for test. | TEXT |
| 126 | Impulse test value (in kVp) . | TEXT |
| 127 | The test certificates of Aluminium/copper conductor, core , insulating paper, porcelain bushings, steel plate used for enclosure of offer transformer is enclosed along with the offer in soft copy.(Yes/ No) | BOOLEAN |
| 128 | All type test report of type tests carried out on transformer at NABL laboratory shall be submitted along with the offer as per cl. XXII (c) of Section (I) i.e. Instructions to tenderers.(Yes/ No) | BOOLEAN |
| 129 | Air pressure test and temperature rise test shall be conducted as per format enclosed with the technical specification along with the offer (Yes/ No) | BOOLEAN |
| 130 | All drawings shall be furnished for each offered item separately along with this offer (Yes/No) | BOOLEAN |
| 131 | Oil absorption calculation sheet shall be furnished for each offered item separately along with this offer (Yes/ No) | BOOLEAN |
| 132 | Heat dissipation calculation shall be furnished for each offered item separately along with this offer (Yes/ No) | BOOLEAN |

| | | |
|-----|--|---------|
| 133 | Flux density calculation sheet with no. of Primary & Secondary turns shall be furnished for each offered item separately along with this offer (Yes/ No) | BOOLEAN |
| 134 | Calculation sheet for 112.5% of Rated V/f ratio (over fluxing calculation sheet) shall be furnished for each offered item separately along with this offer (Yes/ No) | BOOLEAN |
| 135 | Required documents, plant and machinery, list of order executed/under execution shall be furnished for each offered item separately along with this offer (Yes/ No) | BOOLEAN |
| 136 | The information required under Quality Assurance shall be submitted with the offer in physical format & soft copy(Yes/ No) | BOOLEAN |
| 137 | The cost data in the prescribed format shall be submitted with offer in physical format & soft copy (Yes/ No) | BOOLEAN |
| 138 | The performance Guarantee of the transformers in years | TEXT |
| 139 | Power frequency withstand voltage dry & wet in kV(rms) for H.V Bushing | TEXT |
| 140 | Dry lightning Impulse withstand voltage test in kV (peak) Stating the wave form adopted for H.V. bushing | TEXT |
| 141 | No.of radiators providers and location with arrangement | TEXT |
| 142 | Thickness of the radiator of transformer in mm | TEXT |
| 143 | No of radiator fins | TEXT |

Required Documents (To be uploaded online)

| Sr. No. | NAME | SECTION | ITEM | DESCRIPTION |
|---------|---|--------------------|-------------------------|--|
| 1 | Type test reports | Technical Section | 25KVA11/0.433 KV3PHDIST | Submit Type test certificates from NABL accredited lab such as CPRI/ERDA of offered Item valid for a period of five years. |
| 2 | BIS License & BEE Certificate | Technical Section | 25KVA11/0.433 KV3PHDIST | Submit Valid B.I.S. license and valid BEE certificate for offered items. |
| 3 | Annexure-O | Commercial Section | | Submit Annexure-O regarding declaration of participation as New Supplier in the tender |
| 4 | Experience / Copies of orders executed and Completion Certificate | Commercial Section | | Copies of orders executed by the bidder and order Completion certificate with regards to successful execution of the order / supply of quantity for preceding three financial years as per Qualifying Re |
| 5 | List of orders in hand. | Commercial Section | | List of orders in hand certified by Chartered Engineer/accountant |
| 6 | Manufacturing & testing facilities and Quality Assurance Plan | Commercial Section | | Submit List of in house manufacturing and testing facilities as well as quality control set up available with the tenderer duly seal and signed. |
| 7 | ISO certification | Commercial Section | | Submit ISO for quantity management system and ISO for environmental management system. |
| 8 | Turnover certificate | Commercial Section | | Submit documentary evidence showing annual turnover of last 3 years, certified by Chartered Accountant for preceding three financial years. |
| 9 | Profit & Loss and Balance sheet | Commercial Section | | Submit Profit & Loss and Balance sheet certified by Chartered Accountant for preceding three financial years. |
| 10 | Schedule-'C' | Commercial Section | | Submit the quantity offered in the prescribed format as per schedule 'C'. |
| 11 | Udyam registration. | Commercial Section | | Submit latest Udyam registration. |
| 12 | EMD receipt | Commercial Section | | Submit EMD receipt (Bank Guarantee or Demand Draft). |
| 13 | Manufacturing Capacity | Commercial Section | | Submit documentary evidence (for e.g. SSI/NSIC/Chartered Accountant Certificate) for manufacturing capacity to cover the quantity offered by the bidder and considering orders in hand. |
| 14 | Power of Attorney | Commercial Section | | Submit Notarized power of attorney in favor of appointed agent/representative. |
| 15 | Controlling Stake | Commercial Section | | Submit Certificate from Chartered Accountant for not having controlling stake in more than one entity. |
| 16 | Annexure-F for legal litigation | Commercial Section | | Submit Annexure-F regarding declaration of legal litigations. |

| Sr. No. | NAME | SECTION | ITEM | DESCRIPTION |
|---------|--|--------------------|------|--|
| 17 | Annexure-I for debar undertaking | Commercial Section | | Submit Annexure-I regarding debar undertaking. |
| 18 | Undue Influence | Commercial Section | | Submit Self-undertaking on bidders letter head for not approaching any one for undue influence. |
| 19 | Corrupt & Fraudulent Practice declaration | Commercial Section | | Submit declaration along with bid as per Clause no. XXXII of Section I regarding corrupt and fraudulent practice |
| 20 | No Deviation certificate in respect of Commercial & Technical terms & conditions of tender documents | Commercial Section | | Submit No Deviation certificate in respect of Commercial & Technical terms & conditions of tender documents. |
| 21 | BEE Certificate | Commercial Section | | Submit valid BEE certificate for offered item. |
| 22 | BIS License | Commercial Section | | Submit valid B.I.S. license for offered item. |
| 23 | GST | Commercial Section | | Submit GST registration certificate. |