

## Maharashtra State Electricity Distribution Co. Ltd.

Tender Details		02-08-2023 03:57:30
Tender Code	MMD/T-HTM1-05/0823 VERSION- 2	
Tender Type	Procurement Tender	
Type Of Bid	Two Bid	
Description	Procurement of 33 KV / 11 KV, 5 MVA and 10 MVA power transformers	
Estimated Cost (In Lakhs)	27435	
Basis of prices	Firm Price Basis	
Tender Validity	120	
Delivery Requirement (In Months)	9	
Tender on rate contract basis	NO	
Tender Fee (In INR)	25000	
GST In INR (@18% on Tender Fee: SAC No.	4500	
Total Tender Fee Amount including GST in INR.	29500	
Contact	Shri Kirankumar Shinde , 7045791361 ,cemmcmsedcl@gmail.com	
Pre-Qualifying Req	As per qualifying requirement clause of section III	
Budget Type	NA	
Scheme Code	null	
Scheme Name		
Department	Material Management Cell	
Office Type	HO	
Location Type	Corporate Office	
Designation	Executive Engineer(Distribution)	
Pre-Bid Meeting Address	THE CHIEF ENGINEER Maharashtra State Electricity Distribution Co. Ltd. Material Management Department, Plot No. G-9, "Prakashgad" First floor, Prof. A. K. Marg, Bandra(E), Mumbai-400051.	
Bid Opening Address	THE CHIEF ENGINEER Maharashtra State Electricity Distribution Co. Ltd. Material Management Department, Plot No. G-9, "Prakashgad" First floor, Prof. A. K. Marg, Bandra(E), Mumbai-400051.	
Version No	2	
Call for Deviation	YES	
Is Annexure C1 Applicable	YES	
Is Manufacturer Applicable	YES	
Is Trader Applicable	NO	
Minimum % of Offered Quantity	20	
Is Power Supplier Applicable	NO	
Tender Sale Start Date	01-08-2023 20:00	
Tender Sale End Date	22-08-2023 12:00	
Bid Start Date	01-08-2023 20:05	
Bid End Date	22-08-2023 15:00	
Pre-Bid Meeting Date	08-08-2023 17:00	

Techno-Commercial Bid opening on	22-08-2023 15:30
Price Bid opening on	Will be declared later
Annexure C1 Opening Date	Will be declared later
Winner Selection Date	Will be declared later
Can Bidder opt for EMD Exemption	YES
Is Annexure-E [Consent for MSEDCL Standard Technical Specifications and GTP] Applicable ?	NO



MATERIAL MANAGEMENT DEPARTMENT  
MAHARASHTRA STATE ELECTRICITY DISTRIBUTION CO. LTD.  
Tender No. MMD/T-HTM1-05/0823

## **TENDER BID NOTICE**

The Chief Engineer, Material Management Department (MMD), on behalf of Maharashtra State Electricity Distribution Company Limited (the Purchaser), hereby invites sealed bids from eligible bidders for procurement of 33 KV / 11 KV, 5 MVA and 10 MVA power transformers. Entire bidding document is available online on <https://etender.mahadiscom.in/eatApp/> as per date indicated below. Any changes in the Bid Schedule, corrigendum etc. shall also be notified via MSEDCL's website. Prospective bidders are therefore requested to regularly check the website for any updates.

**Tender No. MMD/T-HTM1-05/0823**

**Estimated Tender Cost: Rs. 274.35 Crore inclusive of 18% GST.**

**Tender Fee:** Rs. 25,000.00 + 18% GST

The bidder should submit non-refundable Bid Fee of Rs. 25,000.00 + 18% GST paid through online payment only, prior to the dead line for submission of bids as per the procedure laid by the MSEDCL.

**Earnest Money Deposit:** The bid must be accompanied with EMD @ 0.5% (Half Percent) value of the estimated cost of offered quantity of the tender in the form of BG as per the Annexure-M enclosed with tender documents having validity of 120 days from opening of tender. Interest shall not be allowed on EMD.

The scanned copy of the online payment receipt / Demand Drafts / BG should be uploaded (in e-tendering) and the Demand Drafts/BGs should be submitted to this office on or before submission date and time.

Calendar of Events Event	Date and Time
Begin Sale of Bid Document	01.08.2023
Date and time of submission of Bids	22.08.2023 at 15:00 hrs.
Date and time of Bid Opening	22.08.2023 at 15:30 hrs.
Date and time of Pre bid meeting	08.08.2023 at 17:00 hrs. Online Google Meet joining info : <a href="https://meet.google.com/esh-ewsp-wpw">https://meet.google.com/esh-ewsp-wpw</a>

**THE CHIEF ENGINEER**  
**Maharashtra State Electricity Distribution Co. Ltd.**  
**Material Management Department,**  
**Plot No. G-9, "Prakashgad" First floor, Prof. A. K. Marg,**  
**Bandra(E), Mumbai-400051.**  
**E-mail- [cemmcmsedcl@mahadiscom.in](mailto:cemmcmsedcl@mahadiscom.in), [cemmcmsedcl@gmail.com](mailto:cemmcmsedcl@gmail.com)**

**MAHARASHTRA STATE ELECTRICITY DISTRIBUTION CO. LTD.**

TENDER FOR

Procurement of 33 KV / 11 KV, 5 MVA and 10 MVA power transformers.

Tender No: MMD/T-HTM1-05/0823



**OFFICE OF THE CHIEF ENGINEER,  
Maharashtra State Electricity Distribution Co. Ltd.  
Material Management Department,  
Plot No. G-9, "Prakashgad" First floor, Prof. A. K. Marg,  
Bandra (E), Mumbai - 400 051.  
E-mail- [cemmcmsedcl@mahadiscom.in](mailto:cemmcmsedcl@mahadiscom.in)  
[cemmcmsedcl@gmail.com](mailto:cemmcmsedcl@gmail.com)**

## INDEX

SR. NO.	CLAUSE NO.	DESCRIPTION
1	-	BID NOTICE
2	-	SECTION I: INVITATION TO TENDER AND INSTRUCTION TO BIDDERS
3	I	SCOPE OF WORK
4	II	QUALIFYING REQUIREMENTS
5	III	PRICES
6	IV	TAXES
7	V	BASIS OF PRICES
8	VI	PRICE VARIATION
9	VII	DELIVERY
10	VIII	OFFERING THE MATERIAL
11	IX	CONFLICT OF INTEREST
12	X	QUOTATION
13	XI	AMBIGUITY IN QUOTATION
14	XII	FILLING IN OF ANNEXURE
15	XIII	ADDITIONS/ALTERATIONS PROHIBITED
16	XIV	BIS LICENSE AND BEE CERTIFICATE
17	XV	MANDATORY REQUIREMENT OF SUBMISSION OF OFFER
18	XVI	SUBMISSION OF DRAWING & BILL OF MATERIAL
19	XVII	NAME OF AUTHORIZE REPRESENTATIVE
20	XVIII (A)	OFFER OF MICRO & SMALL ENTERPRISES
21	XVIII (B)	PREFERENCE TO INDUSTRIAL UNITS LOCATED IN MAHARASHTRA AND OFFERS BY MATCHING RATES WITH LOWEST ACCEPTABLE BIDDER
22	XVIII (C)	MATCHING OF RATES
23	XIX	QUANTITY ALLOCATION
24	XX	EARNEST MONEY DEPOSIT (EMD)
25	XXI	SIGNING OF THE TENDER DOCUMENTS
26	XXII	SUBMISSION / SUPERSCRIBING OF THE TENDER DOCUMENTS
27	XXIII	TIMELY SUBMISSION OF OFFER
28	XXIV	PURCHASER'S RIGHT
29	XXV	DISREGARD OF TENDER CONDITIONS
30	XXVI	PROHIBITION FOR POST TENDER CORRESPONDENCE
31	XXVII	RIGHT TO ORDER OUT QUANTITY IN VARIANCE TO OFFERED QUANTITY
32	XXVIII	ACCEPTANCE OF TENDER
33	XXIX	NOTIFICATION OF AWARD
34	XXX	EARNEST MONEY OF UNSUCCESSFUL BIDDER
35	XXXI	VALIDITY OF OFFERS
36	XXXII	DECLARATION FROM BIDDER
37	XXXIII	CORRUPT OR FRAUDULENT PRACTICES
38	XXXIV	INFLUENCE
39	XXXV	TENDER FEES EXEMPTION
40	XXXVI	PRE-BID MEETING
41	XXXVII	CLARIFICATION ON DEVIATIONS
42	-	CERTIFICATE
43	-	<b>Section II: CONDITIONS OF SUPPLY</b>
44	1	EFFECT OF CONTRACT
45	2	QUALITY OF SUPPLIES

SR. NO.	CLAUSE NO.	DESCRIPTION
46	3	MATERIAL AND COMPONENTS
47	4	ACCEPTANCE OF SUPPLIES/INSPECTION
48	5	RIGHT TO CARRY OUT INSPECTION DURING MANUFACTURING
49	6	RIGHT TO REVISE DESPATCH INSTRUCTIONS, DELIVERY SCHEDULE AND TO DEFER SUPPLIES
50	7	WAGAN LOADS/TRUCK LOADS
51	8	ROAD TRANSPORT
52	9	DESPATCH INTIMATION
53	10	BILL OF MATERIALS
54	11	PACKING LIST
55	12	REPLACEMENT OF GOODS LOST, BROKEN OR DAMAGED
56	13	REPLACEMENT OF REJECTED MATERIALS
57	14	MATERIAL DESPATCHED AND PROGRAMME
58	15	MATERIAL RECEIPT & SUBMISSION OF BILLS AT CONSIGNEE
59	16	PAYMENT OF BILLS
60	17	TAXES
61	18	DEDUCTION
62	19	GUARANTEE
63	20	(I)LIFTING OF REJECTED/DAMAGED MATERIALS FROM STORES AND (II)LIFTING OF FAILED TRANSFORMERS FROM DIVISION FILTER UNIT
64	21	LIQUIDATED DAMAGES FOR LATE DELIVERY
65	22	ORDER PLACED ON TIME PREFERENCE BASIS (WHEREVER APPLICABLE)
66	23	FORCE MAJEURE CLAUSE
67	24	ACCEPTANCE OF LOWER FORD RATE OFFERED IN SUBSEQUENT TENDER
68	25	PERFORMANCE OF CONTRACT:
69	26	CONTRACT PERFORMANCE DEPOSIT
70	27	POWER OF ATTORNEY:
71	28	SETTLEMENT OF DISPUTE
72	29	JURISDICTION:
73	30	TERMINATION OF CONTRACT
74	31	DEBAR / BLACKLISTING OF MANUFACTURER
75	32	TAX DEDUCTED AT SOURCE
76		<b>Section III:</b>
77	I	QUANTITY PROCUREMENT
78	II	QUALIFYING REQUIREMENT
79		<b>Formats:</b>
80	-	ANNEXURE B- QUANTITY, PRICE AND DELIVERY PERIOD
81	-	<u>ANNEXURE C-1 : MATCHING RATE</u>
82	-	<u>ANNEXURE - D : TECHNICAL SPECIFICATION</u>
83		ANNEXURE - E : CONSENT FOR MSEDCL STANDARD TECHNICAL SPECIFICATIONS & GTP
84		ANNEXURE - F : LEGAL LITIGATION UNDERTAKING BY BIDDER
85	-	ANNEXURE - G :PRICE VARIATION
86	-	ANNEXURE - H :GUARANTEED TECHNICAL PARTICULAR
87		ANNEXURE - I: DECLARATION FORMAT.
88	-	ANNEXURE - J : DISPATCH INSTRUCTIONS
89	-	ANNEXURE - K : LIST OF STORES
90		ANNEXURE - L : INSPECTION CALL FORMAT
91	-	ANNEXURE - M : BANK GUARANTEE FORMAT FOR EMD

<b>SR. NO.</b>	<b>CLAUSE NO.</b>	<b>DESCRIPTION</b>
92	-	ANNEXURE – N : BANK GUARANTEE FORMAT FOR CONTRACT PERFORMANCE DEPOSIT
93	-	FORMAT-1 : ANNEXURE – U-I - INDEMNITY BOND
94		FORMAT-2 : UNDERTAKING FOR NOT APPROACHED ANY ONE FOR UNDUE INFLUENCE
95		FORMAT-3 : CERTIFICATE FROM CHARTERED ACCOUNTEANT FOR NOT HAVE CONTROLLING STACK IN MORE THAN ONE ENTITY APPLIED FOR THE TENDER / BID
96		FORMAT-4 : CERTIFICATE FROM CHARTERED ACCOUNTANT FOR AVERAGE ANNUAL TURNOVER
97		FORMAT-5 : CERTIFICATE FOR NO DEVIATION

## **SECTION-I**

**INVITATION TO TENDER AND INSTRUCTION TO BIDDERS**

**TENDER FORM (NOT TRANSFERABLE)**

**(TO BE SUBMITTED ONLINE DULY FILLED IN AND DIGITALLY SIGNED)**

To be submitted online not later than the date mentioned in the tender details. For participating in tender opening, the bidder can login at the specified time and date of opening of the tender, if he desires so.

The bidder is requested to quote his lowest rates F.O.R. destination for the supply of materials. The material is required at various places in the State of Maharashtra. The tender documents duly filled-in and digitally signed, are to be submitted online before due time & date of the submission of tender in prescribed form.

The modifications made to the terms & conditions shall applicable to this tender only.

**FOR CHIEF ENGINEER (M.M.DEPARTMENT)**



**INSTRUCTIONS TO THE BIDDERS****I SCOPE OF WORK:**

The scope of work under this tender is for design, engineering (wherever applicable), manufacture, inspection & testing before dispatch, packing and supply of material / equipment as specified in Annexure-D (Technical Specifications) at various destination sites / stores centers of the purchaser in Maharashtra.

The actual quantity that will be procured may vary depending upon the site requirement. The quantity advertised against various capacities can undergo change.

The list of various destination sites / stores centers of the purchaser is enclosed as Annexure K.

**II Qualifying Requirements:**

Qualifying requirement will be as per Section-III.

**III PRICES:**

(i) Prices are acceptable only on F.O.R. destination basis inclusive of Goods and Service Tax (GST for brevity) i.e. Integrated GST (IGST) for outside State / Central GST+ State GST (CGST+SGST) for within State, risk in transit, freight showing the break-up as desired in the Annexure 'B'. It shall be noted that quotations not conforming to F.O.R. destination basis inclusive of IGST/(CGST+SGST) etc. and to the unit as specified in Annexure 'B', shall be rejected even though the bidder's offer may be lowest. The bidder shall quote Ex-Works Price and element of freight and insurance along with applicable rate of IGST/(CGST+SGST). The F.O.R. destination price i.e. up to site or the Store Centre of the purchaser as the case may be inclusive of IGST/(CGST+SGST), risk in transit and freight will be programmatically calculated. While raising the invoices, however, IGST/(CGST+SGST) should be shown separately in the invoice raised.

(ii) For each of the items quoted, bidder shall specify offered quantity. However, the offered quantity shall not be less than 20% of the advertised quantity (Advertised quantity means the quantity required as indicated in Annexure 'B' / Price Bid) so as to deliver the said quantity within the delivery requirement of the Purchaser as indicated in the tender documents.

**IV TAXES:**

(i) The Purchaser shall be registered under Goods and Service Tax Act and should comply with all the statutory compliance requirements of GST Law diligently.

(ii) It is imperative for the bidder to indicate the amount of IGST/(CGST+SGST) included in their price while giving the break-up of F.O.R. destination price in Annexure 'B', failing which, the offer will be treated as ambiguous and will be rejected as per the provisions of clause X of tender form.

(iii) After awarding the contract, the supplier shall not charge any additional amount towards GST; during the currency of contract except statutory variation by Central / State Government in normal (full) rate of integrated GST. In case the GST is decreased than the rate indicated in the price bid, the benefits of the

reduction in the GST shall be passed on to the purchaser. The increase in the GST rate due to increase in turnover during the contractual delivery period shall not be charged to the purchaser.

- (iv) Necessary documentary evidence for the GST claimed shall be submitted along with the bills.

**V BASIS OF PRICES:**

The bidder shall quote the prices on firm price basis, as has been specifically brought out in the Tender Details. For any deviation in this regard, the offer shall be summarily rejected.

**VI PRICE VARIATION:**

Not applicable.

**VII DELIVERY:**

- (i) Bidder is requested to quote delivery F.O.R. DESTINATION only & only in the unit of the item specified in Annexure 'B' i.e. if the quantity is in sets or in tones or in numbers or in kilometers or in coils, the rate of delivery shall only be in the same unit.
- (ii) It is mandatory on the part of the tenderer to quote the delivery on monthly basis. If the offered delivery is indicated on quarterly basis, then the delivery would be counted proportionately in three equal installments per month for liabilities of the contract including levy of liquidated damages.
- (iii) Size mix for the purpose of delivery, when delivery is quoted in assorted items, shall be determined by the Purchaser while issuing the A/T or dispatch instructions and will be binding on the bidder. The Purchaser will also have the liberty of modifying the size mix for the purpose of delivery, even after the A/T is issued.
- (iv) Offer shall be rejected if the commencement period and rate of delivery per month is not indicated.
- (v) The scheduled delivery period is 9 months from the letter of award will be as below;
- Commencement Period (CM): Min. 10% of offered quantity within 2 months.
- Completion Period (CP): Balance offered quantity in 7 or less months in equated lots.
- (vi) MSEDCL may issue dispatch instructions as per requirement. The quantity demanded per consignee may be less than or equal to monthly lot specified in contract. Wherever as per demand, if the quantity to be supplied to a consignee in a particular month is less than monthly lot quantity; the said quantity will be treated as lot quantity for the purpose of delivery and payment.
- (vii) MSEDCL may instruct the supplier to withhold entire or part of monthly supply of material for a specified period by giving two months advance instruction.
- (viii) Time being the essence of contract, the supplier shall strictly maintain monthly delivery schedule.

The bidder is advised to get their type tests & drawing approval immediately after placement of LoA from Chief Engineer (Testing & QC) so that the material is received by the purchaser well within the committed delivery period. If there is any delay in delivery of material as per schedule, the undelivered quantity as per schedule can be diverted to other good performing bidder.

**VIII OFFERING THE MATERIAL:**

- (A) The bidder shall offer the material as per MSEDCL technical specifications as per Annexure-D and shall have to fill the entire GTP.
- (B) The person / entity should not have controlling stake in more than one entity applied for the tender / bid. **Necessary certificate duly certified by Chartered Accountant to this effect shall be submitted along with the tender documents.**
- (C) Factory address, from which the bidder intends to supply the material against the tender, shall be as indicated in the latest approved online vendor registration form on e-tendering through which the vendor is submitting the offer.
- (D) The bidder shall offer the rates, taxes as applicable for the factory location indicated in his latest approved online vendor registration form on e-tendering through which he is submitting his offer.

**IX CONFLICT OF INTEREST**

A bidder may be considered to have a conflict of interest with one or more parties in a bidding process if they:

- (a) Have controlling shareholders in common; or
- (b) Receive or have received any director in direct subsidy from any of them; or
- (c) Have the same legal representative for purposes of a bid; or
- (d) Have a relationship with each other, directly or through common third parties, that puts the bidder in a position to have access to information about or influence on a bid of another bidder, or influence the decisions of the purchaser regarding the bidding process.

Bidders found to be in conflict of interest, shall be disqualified.

**X QUOTATION:**

- (i) Bidder shall quote his rate per unit specified in Annexure 'B' / Price Bid in figures.
- (ii) Bidder's printed terms and conditions will not be considered as forming part of the tender.

**XI AMBIGUITY IN QUOTATION:**

The bidder is requested to please make a note that in case of ambiguous terms in respect of offered quantity in Annexure- B and schedule 'C', F.O.R. condition, GST, basis of price (i.e. firm / variable) or if the blanks are left out in the offer, the item / tender shall be rejected.

**XII FILLING IN OF ANNEXURE:**

The bidder is requested to ensure that the comments against each and every item/clause of Annexure shall be clearly filled in and answered. Any item/clause shall not be left

blank or unanswered. If any item /clause is not applicable, the “Not Applicable (N.A.)” check box shall be selected.

**XIII ADDITIONS/ALTERATIONS PROHIBITED:**

The bidder shall not make any additions, alterations or changes in the Tender Form and the Conditions of Tender & Supply (Annexure ‘A’) including the description of material mentioned in Annexure ‘B’. They should quote rate for the material described or click the check box ‘Not quoted’ against each of the item in Annexure ‘B’/ Price Bid.

**XIV B.I.S. LICENCE AND BEE CERTIFICATE (If Applicable):**

A scanned copy of valid BIS License & BEE certifications for offered items ratings duly sealed & signed must be uploaded and submitted along with offer, failing which, the offer shall be rejected.

In case the validity of the BIS license / BEE certifications is expiring before date of submission of tender, necessary documentary proof of having applied for renewal of validity of the BIS license / BEE certifications must be uploaded while submitting the bid. The renewed copy of the BIS License / BEE certifications shall be submitted before commencement of supply.

However, valid BIS license / BEE certifications scan copy of offered material must be submitted by the qualifying bidders before commencement of supply, failing which their order will be cancelled with financial liability on supplier.

**XV MANDATORY REQUIREMENT OF SUBMISSION OF OFFER:**

The offer shall be submitted online duly filled in; attaching all the required documents, completed in all respects and should be digitally signed.

**XVI SUBMISSION OF DRAWING & BILL OF MATERIAL :**

The bidder shall submit the drawings and bill of material conforming to the tender specification wherever applicable. In such cases, the offer without the drawings and bill of material shall not be evaluated and considered. The drawings and bill of material submitted along with the bid shall not be considered for evaluation of the offer but the drawings and bill of material of the successful bidder shall be scrutinized when the Purchaser decides to accept such bid. It may, however, be noted that Purchaser’s action of evaluation of the tendered bid would not mean approval of the drawings and bill of material submitted along with the tender bid.

The bidder shall depute his authorized representative for discussion on the drawings, either immediately on hearing from the Purchaser or after receipt of Letter of Award. The formalities like submission of drawings, bill of material etc. and getting the same approved by the Purchaser shall be completed by the successful bidder within TEN DAYS from the date of Letter of Award of the contract. The approval to drawings complete in all respects mentioned in technical specifications (Annexure-D) will be accorded within SEVEN working days thereafter. Any delay in this regard shall lead to cancellation of the Letter of Award at the risk and cost of the bidder. The supplies against the contract shall conform to the approved detailed drawings / bill of material and the detailed technical specifications.

**XVII NAME OF AUTHORIZED REPRESENTATIVE:**

The digital certificate shall be in the name of person authorized by the firm. In case, the digital certificate is compromised or the person holding the digital certificate is no longer authorized to digitally sign the tender, it is the responsibility of the bidder to revoke this certificate and obtain the fresh certificate. While submitting the bids online only valid digital certificate shall be used. The vendors are requested to check the validity of digital signature and prior to the expiry date & they are requested to get their Digital signature key validated before expiry of the same. MSEDCL shall not be responsible for Non-submission of any of the Bids (Techno Commercial Bid, Deviation Bid, Price Bid, Annexure - C-1) by vendors due to expired/Invalid Digital signature.

The bidder is responsible for all the contractual liabilities and responsibilities thereof.

In case the bidder authorizes the representative to deal on behalf of the bidder, the name and address of such person should be informed to the purchaser. The bidder shall submit the power of Attorney in favour of representative duly executed before the Notary. In the absence of the Power of Attorney, the purchaser shall not deal with the representative.

**XVIII (A) Offer of Micro & Small Enterprises: (If matching is called)**

The bidder registered with Directorate of Industries of Government of Maharashtra for manufacturing the items tendered/offered and those who have attached valid certificate at the time of vendor registration shall be considered for concessions applicable and procurement of reserved items as per GoM G. R. dtd. 30-10-2015 amended up to date. These benefits shall be available only to those items approved during the registration process and subsequent updates in registration up to the submission of this tender.

Based on concession of Central Government's Micro & Small Enterprises office order dtd. 23-03-2012, 241 items are being kept reserved. As per above reservation of items 100% reserved items to be purchased from Micro & Small Enterprises out of which 20% reserved items to be purchased from S.C./S.T. enterprises. Reservation is applicable for a limited period unless & until re-examined. If Micro & Small Enterprises participated in the tender and the tendered item is not reserved, then 20% order with L-1 rate to be given to Micro & Small Enterprises and out of this 20%, 4% to be given to S.C./S.T. enterprises.

If there are any specific Government Directives such as reservation of items for units in Maharashtra, non-eligibility of preference to SSI units etc. for particular items, price and purchase preference etc. the same would be applicable irrespective of the fact that it has not been specifically incorporated in the tender notice and/or tender documents.

**(B) PREFERENCE TO INDUSTRIAL UNITS LOCATED IN MAHARASHTRA AND OFFERS BY MATCHING RATES WITH LOWEST ACCEPTABLE BIDDER**

**The lowest acceptable rate will be the unit rate worked out without considering IGST/(CGST+SGST) as applicable and the same rate will be considered as applicable to the respective bidder who has agreed to accept order at lowest acceptable rate.**

The lowest acceptable rate is known only on the date of decision by the Competent Authority, hence the lowest acceptable rates of the tender cannot be declared in advance, however lowest acceptable rate of the tender would be equal to or more than the lowest rate received in the tender.

**(C) Matching of rates:**

The confirmation for acceptance of the order at the lowest acceptable rate shall be given in the format as per Annexure 'C-I' of the tender documents by the bidder other than L-1. The same should be submitted online on or before the due time and date of submission of Annexure- 'C-1'. The confirmation shall be opened online on due time and date of opening of Annexure-'C-1'. Item wise and bidder wise schedule for submission and opening of Annexure 'C-1' shall be communicated separately by auto generated e-mail and on the website. MSEDCL reserves the right to call & open the Annexure 'C-1' of limited bidders as per their price ranking and preference to industrial units located in Maharashtra.

In the above confirmation, if the bidder indicates any rate, then the confirmation given by the bidder will not be considered as valid.

Above confirmation for the quantity less than as indicated in Clause III (ii) (offered quantity shall not be less than 20 %) of Instructions to the bidder shall not be acceptable.

The prices indicated in the original offer shall not be considered as valid once offer for acceptance of order by matching rates is given. In the event of withdrawal of offer by matching rates within the validity period, the entire offer against the tender shall become invalid and shall be summarily rejected and the earnest money paid by the bidder shall be forfeited.

The lowest acceptable tenderer would be considered for awarding order for quantity subject to his capacity and capability as under.

**XIX QUANTITY ALLOCATION:**

- 1) If L-1 bidder is within Maharashtra State and if total tender quantity for quoted item is offered by L-1 then 100 % quantity will be awarded to L-1 bidder for quoted item.
- 2) If L-1 bidder is within Maharashtra State and offered quantity is less than the tender quantity for quoted item then,
  - a) Quantity allotted to L-1 bidder will be equal to quantity offered by him.
  - b) Balance quantity after allotment as (a) above, will be distributed among Maharashtra State bidders as per their price ranking (if ready to match with L-1 rate) subject to maximum 50 % of total tender quantity for quoted item to Maharashtra State bidders including L-1 bidder.
  - c) Any balance quantity after allotment as (a) & (b) above, will be distributed as per their price ranking (if ready to match with L-1 rate) irrespective of bidder is Maharashtra or out of Maharashtra state bidder including partial allotment if any to Maharashtra bidder in (b) above.
- 3) If L-1 bidder is outside Maharashtra State then,

- a) If the L-1 bidder offered more than 50 % of tendered quantity for quoted item then maximum of 50 % of tender quantity for quoted item will be allotted to L-1 bidder.
- b) If the L-1 bidder offered less than 50 % of tendered quantity for quoted item then quantity equal to offered quantity for quoted item will be allotted to L-1 bidder.
- c) Balance quantity after allotment as (a) or (b) above, will be distributed among Maharashtra State bidders as per their price ranking for maximum 50 % of required quantity. (if ready to match with L-1 rate).
- d) Any balance quantity after allotment as (a) ,(b) & (c) above, will be distributed as per their price ranking (if ready to match with L-1 rate) irrespective of bidder is Maharashtra or out of Maharashtra state bidder including partial allotment if any.
- e) If all bidders including L-1 bidder are from outside Maharashtra state and if the offered quantity of L-1 bidder is 100 % then entire quantity will be allotted to L-1 bidder. If quantity offered by L-1 bidder is less than 100 %, then after allotting to L-1 bidder balance quantity will be allocated to remaining bidder who matched the L-1 rates as per price ranking & quantity quoted.
- f) In spite of above the quantity allocation will be at the sole discretion of MSEDCL.

**XX EARNEST MONEY DEPOSIT (EMD):**

The bidder should pay the Earnest Money @ 0.5% (Half Percent) value of the estimated cost of offered quantity of the tender in the form of Demand Draft or Bank Guarantee as per the Annexure-M enclosed with tender documents having validity of 120 days from opening of tender. Interest shall not be allowed on EMD. EMD shall be forfeited (i) in case the bidder withdraws the tender / offer during the validity period (ii) in case the bidder fails to pay the performance deposit if the contract is awarded.

However, bidders from the following categories are exempted from payment of earnest money deposit.

- 1) All Government and semi Government institutions under Govt. of Maharashtra and Zilla Parishad in Maharashtra and fully owned undertaking of any State Govt. and Govt. of India only for the items manufactured by such institutions.
- 2) Micro and Small Enterprises registered under Micro, Small and Medium Enterprises Development Act-2006 only for the items mentioned in their permanent registration certificate at the time of vendor registration.
- 3) The bidder registered with N.S.I.C. and those who have attached valid N.S.I.C. Registration Certificate for the items mentioned in their permanent registration certificate at the time of vendor registration.

The benefits mentioned in (1) to (3) above shall be available only to those items approved during the registration process and subsequent updates in registration up to the date of submission of this tender.

Exempted bidders should upload a latest valid certificate issued by any approved body of 'Ministry of Small & Medium Enterprises' (MSME) such as 'National Small Industries Corporation' (NSIC) or 'Udyam registration' for EMD exemption.

**XXI SIGNING OF THE TENDER DOCUMENTS:**

Offer shall be submitted along with the tender documents and duly filled in with all Sections / Annexures / Appendixes / Schedules etc. The offer shall be signed with valid digital signature.

**XXII SUBMISSION / SUPERSCRIBING OF THE TENDER DOCUMENTS:**

The offer is to be submitted as follows.

**(a) Online Submission:**

- (i) Techno-Commercial Bid (Part-I): This part shall contain all technical and commercial aspects of the bid and documents supporting the same except the Price Bid.

**The bidder is requested to please make a note that in case of the Price Bid (Part-II) is submitted instead of Techno-Commercial Bid in Part-I or submitted Price Bid (Part-II) along with Techno-Commercial Bid in Part-I, the offer shall be rejected.**

- (ii) Price Bid (Part-II)

This part shall contain only the Price Bid strictly in the prescribed format, i.e. Annexure 'B'.

**(b) Off line Submission:**

Physical submission of documents (Part-III) – Not mandatory.

Envelope for this part shall contain documents like Type Test Reports, Drawings, Bill of Material, Catalogues etc. wherever applicable as per technical specification and they shall be scanned and these scanned documents to be taken into PDF format on CD media (2 sets) and are to be submitted to Executive Engineer (HTM-1) in the office of Chief Engineer, Material Management Department in sealed envelope on or before due date & time of submission.

**METHOD OF SUBMISSION OF PART-III AND THEIR OPENING:**

This envelope shall be individually sealed and shall be superscribed with the name and address of bidders and the following information before posting or delivering the same:

- i. Tender No.
- ii. Due date and time of submission.
- iii. Due date and time of opening.

Envelope as above shall be submitted on or before the prescribed due date and time of submission and shall be opened on due date and time of opening as prescribed.



In case of bidders whose techno-commercial bid is acceptable, their Price Bids will be opened at a later date. This date shall be intimated to such bidders separately.

**XXIII TIMELY SUBMISSION OF OFFER:**

- (a) The bid is to be submitted online on or before due date and time of submission to the Purchaser at website.
- (b) It is advisable to submit the digitally signed offer sufficiently in advance of due date and time so as to avoid last minute congestion of network / server.
- (c) Offer received after the due date and time of submission shall not be accepted.
- (d) In case, the due date of opening of tender happens to be holiday, the offer shall be opened on the next working day at the same time.

**XXIV PURCHASERS RIGHT:**

The Purchaser reserves the right to reject any offer without assigning any reason whatsoever.

The Purchaser reserves the right to make any changes in terms & condition at any stage of the process without assigning any reason whatsoever.

If any type of legal litigation against MSEDCL is pending in any court/Forum against/by the bidder or its sister concern/Director/Partner/Proprietor, then purchaser reserves the right to reject partly or fully their bid without assigning any reasons thereof.

Bidder has to submit the declaration as per Annexure-F regarding no any type of legal litigation against MSEDCL is pending in any court/Forum against/by the bidder or its sister concern/Director/Partner/Proprietor.

**XXV DISREGARD OF TENDER CONDITIONS:**

Tender containing any deviations / additions / alterations / changes in the conditions of the tender and supply as stated in Annexure 'A', 'B', 'C-I', 'D', 'E' and schedule 'C' shall not be acceptable.

The bidder having digitally signed all the tender documents indicates any deviations / additions / alterations / changes in the covering letter, unrelated annexure and schedules of the offer or elsewhere, the same shall be ignored and the offer shall be treated as meeting with all specified tender conditions.

**XXVI PROHIBITION FOR POST TENDER CORRESPONDENCE:**

The Bidder should note that no correspondence shall be entertained or considered after the due date and time of submission of tender unless otherwise sought by the Purchaser.

The Bidder should also note that no correspondence shall be entertained or considered after the placement of LoA/AT unless otherwise sought by the Purchaser.

**XXVII RIGHT TO ORDER OUT QUANTITY IN VARIANCE TO OFFERED QUANTITY:**

The Purchaser reserves the right to order out / procure any quantity in excess of the offered quantity with change in delivery period with mutual consent. The quantity specified may be for dispatch to one destination or several places.

**XXVIII ACCEPTANCE OF TENDER:**

The Purchaser does not bind itself to accept the lowest or any tender; neither will any reasons be assigned for the rejection of any tender or part of tender. It is also not binding on the Purchaser to disclose any analysis report on tender/samples. The bidder on his part binds himself to supply any item or items selected from his offer in part or whole at the option of the Purchaser.

**XXIX NOTIFICATION OF AWARD:**

Notification of Award of contract will be made by a letter of Award, to be sent by registered post or given by hand or by E-mail to the successful bidder by the Purchaser. It could also be made by e-mail to be confirmed in writing by registered post to the successful bidder by the Purchaser.

**XXX EARNEST MONEY OF UNSUCCESSFUL BIDDER:**

Earnest money deposit will be returned to the unsuccessful bidder by RTGS within 7 (seven) working days after the tender has been decided and on submission of receipt of E.M.D. payment to the G.M. (F&A-SB), MSEDCL, Prakashgad, Prof. A.K. Marg, Bandra (East), Mumbai-400051. Earnest money deposit in the form of BG will be returned to the unsuccessful bidder within 7 (seven) working days by Chief Engineer, Material Management Department after the tender has been decided.

**XXXI VALIDITY OF OFFERS:**

The bidder shall keep the offer valid for acceptance up to and including last date of calendar month, covering the date of completion of 120 days (one hundred and Twenty days) from the date of opening of the tender and shall also agree to extend the period of validity required by the Purchaser. The bidder shall not be allowed to modify or change the conditions of the tender while extending the period of validity.

**XXXII DECLARATION FROM BIDDER:**

In order to ensure participation of reliable and honest bidders / contractors / vendors, etc. the bidder shall submit the declaration along with the bid in Annexure-I.

**XXXIII CORRUPT OR FRAUDULENT PRACTICES:**

The Maharashtra State Electricity Distribution Company Ltd. and the State require that bidders / suppliers / contractors observe the highest standard of ethics during the procurement and execution of such contracts. In pursuance of this policy, MSEDCL:

(a) defines for the purposes of this provision, the terms set forth below as follows:

- (i) "corrupt practice" means behavior on the part of officials in the public or private sectors by which they improperly and unlawfully enrich themselves and / or those close to them, or induce others to do so, by misusing the position in which they are placed, and it includes the offering, giving, receiving or soliciting of anything of value to influence the action of any such official in the procurement process or in contract execution; and
- (ii) "fraudulent practice" means a misrepresentation of facts in order to influence a procurement process or the execution of a contract to the detriment of the Employer, and includes collusive practice among bidders (prior to or after

bid submission) designed to establish bid prices at artificial non-competitive levels and to deprive the Employer of the benefits of free and open competition.

- (b) will reject a proposal for award if it determines that the bidder recommended for award has engaged in corrupt or fraudulent practices in competing for the contract in question;
- (c) will declare a firm ineligible, either indefinitely or for a stated period of time, to be awarded an MSEDCL contract if at any time it determines that the firm has engaged in corrupt or fraudulent practices in competing for, or in executing, an MSEDCL contract.

**XXXIV INFLUENCE:**

Any efforts by the bidders to influence the owner during evaluation process before order placement will be rejected. Similarly deviation in the term of payments, penalty, performance deposit, delivery period will be treated as non-responsive quotation/offer and will not be considered for evaluation/order placement.

Bidder shall submit the undertaking certifying that they have not approached any one for undue influence.

**XXXV TENDER FEES EXEMPTION:**

Tender fee to be paid at the time of uploading / online submission of the tender. Bidders from the following categories are exempted from payment of Tender fees:

- 1) All Government and semi Government institutions under Govt. of Maharashtra and Zilla Parishad in Maharashtra and fully owned undertaking of any State Govt. and Govt. of India only for the items manufactured by such institutions.
- 2) Micro and Small Enterprises registered under Micro, Small and Medium Enterprises Development Act-2006 only for the items mentioned in their permanent registration certificate at the time of vendor registration.
- 3) The bidder registered with N.S.I.C. and those who have attached valid N.S.I.C. Registration Certificate at the time of vendor registration.

The benefits mentioned in (1) to (3) above shall be available only to those items approved during the registration process and subsequent updates in registration up to the date of submission of this tender.

The tender fee paid against the particular tender shall not be refunded / transferred /adjusted at all.

**XXXVI PRE-BID MEETING:**

- 1) The bidder or its official representative is invited to attend pre-bid meeting (s) which will take place at the place, date and time designated in the Bidding Data.
- 2) The purpose of the pre-bid meeting(s) will be to present the salient features of the bidding documents to the bidders, including the bid submittal requirements, the Conditions of Contract (including payment terms and conditions), the technical features of the project, and to clarify issues and to answer questions on any matter that may be raised by the bidders.
- 3) The bidder is advised to visit the Site and study the bid document thoroughly, and is requested to submit any questions in writing or by E-mail, to reach the Employer not later than one week before the pre-bid meeting.

- 4) Minutes of the meetings, including the text of the questions raised and the responses given will be transmitted without delay to all the prospective bidders through the website <https://etender.mahadiscom.in/eatApp/>. Any modification of the bidding documents listed which may become necessary as a result of the pre-bid meetings shall be made by the Purchaser exclusively through the issue of an Addendum pursuant to Clause and not through the minutes of the pre-bid meetings.
- 5) Non-attendance at the pre-bid meeting will not be a cause for disqualification of a bidder. Nevertheless, senior representatives of the bidders are strongly encouraged to participate in the pre-bid meeting to help ensure that they fully understand the key concerns of the Employer and the Employer's requirements.

**XXXVII CLARIFICATION ON DEVIATIONS:**

The purchaser, if necessary, shall obtain clarifications on deviations within 1 or 2 working days by requesting for such information from any or all the bidders in writing, as may be necessary.

The same should be submitted online on or before the due time and date of submission of Deviation Bid. The clarification shall be opened online on due time and date of opening of Deviation Bid.

The Schedule for submission and opening of Deviation Bid shall be communicated by auto generated e-mail of the e-tender website.

**CERTIFICATE:**

I / We agree to supply the materials at the rates herein tendered by me / us subject to the conditions of tender and supply in Annexure 'A' of this tender which I / We have carefully read and which I / we have thoroughly understood and to which I / we agree. I / we hereby agree to keep this offer open up to the date mentioned in tender details and shall be bound by communication of acceptance dispatched within the validity period.

Seal & Signature of bidder



## **SECTION-II**

### **CONDITIONS OF SUPPLY**

#### **1) EFFECT OF CONTRACT:**

The contract shall be considered as having come in to force and shall be in operation for a period of 9 months from the date of Notification of Award. The bidder whose offer is accepted is hereinafter called “the supplier”.

#### **2) QUALITY OF SUPPLIES:**

All materials supplied shall be strictly as per specification laid down by MSEDCL and in accordance with the approved standard Guaranteed Technical Particulars (GTP), drawings and type test reports.

#### **3) MATERIAL AND COMPONENTS:**

The material and components not specifically stated in this specification but which are necessary for satisfactory operation of the equipment / items specified, shall be deemed to be included unless specifically excluded and shall be supplied without any extra cost.

#### **4) ACCEPTANCE OF SUPPLIES / INSPECTION:**

- i) The supplier shall normally offer at a time, the entire quantity required to be delivered every month as per the delivery schedule indicated at Annexure ‘B’ of A/T for the purpose of inspection by the Purchaser.

Time being the essence of contract; the supplier shall strictly maintain the monthly delivery schedule.

- ii) Materials shall be inspected by the Purchaser’s Executive Engineer / or the representative authorized by the Purchaser before dispatch. An intimation in the prescribed Proforma about the date on which materials shall be ready for inspection, indicating quantity, shall have to be given to the Executive Engineer / or the representative authorized by the Purchaser before dispatch so as to reach him 10 working days in advance, failing which, the supplier shall be responsible for delay in delivery on account of inspection.

The intimation in the prescribed proforma (Inspection call) shall be forwarded on MSEDCL Material Inspection Portal i.e. <https://mip.mahadiscom.in/InspectionPortal/>. Inspection calls sent via any other media will not be entertained and the supplier will be responsible for delay in delivery on account of inspection.

The inspection call should reach to MSEDCL maximum 7 days prior to date of readiness. On receipt of such intimation, the materials shall be inspected within 10 working days from the date of receipt of inspection call. The materials shall be dispatched only after inspection and approval of same by the Inspector. The inspection approval letter shall be valid for a period of 30 days from the date of issue of letter to enable the supplier pack the material and arrange transportation thereof so that material should be reached at the respective consignee within scheduled delivery period.

After this period of 30 days, the validity of this inspection approval letter will lapse. If the material is not reached within scheduled delivery period to respective consignees, the approval of purchaser is to be sought by the supplier for revalidation of inspection approval letter at the sole discretion of MSEDCL.

For quantity supplied beyond contractual delivery period, statutory variations is applicable only when the delayed delivery is attributed to MSEDCL.

- iii) The supplier shall notify the names of the consignees as per DI, to whom the inspected lot would be dispatched. The supplier shall get the copies of inspection approval letter together with witness certificate duly signed by the concerned Inspecting Officer and also mention reference or inspection approval letter on the challan / invoice, failing which any delay occurred in getting the S.R. Notes from the consignees would be solely to supplier's account. The inspection report shall be filled in online on the same day by the Inspector from the site on MSEDCL web portal after the inspection.
- iv) Factory address, from which the bidder has to supply the material, shall be as indicated in the latest approved on line vendor registration form on e-tendering through which the bidder has submitted the offer.
- v) The supplier shall offer inspection call intimation of readiness of material as per the monthly schedule only. In the event, during the inspection by the Purchaser's Inspecting Officer, if it is observed that the quantity actually offered for inspection is less than the quantity indicated for inspection in the inspection call, the Purchaser shall be entitled to recover from the supplier, the actual expenses incurred for arranging the inspection, and the supplier shall not dispute the amount to be recovered.
- vi) The supplier shall submit the test certificates / reports from any NABL approved laboratory or the laboratory of his own for the respective quantity of material, before dispatch. The material shall not be dispatched unless and until the test certificates are approved by the Purchaser.
- vii) All the necessary help shall be extended by the supplier to the authorized representative of the Purchaser to carry out testing of equipment / materials. Testing equipment's shall be arranged by the supplier.
- viii) MSEDCL may issue the dispatch instructions (DI) to deliver the ordered quantity to the bidders in Maharashtra within same districts of factory location of the supplier. However, it will not be binding on the MSEDCL; supplier has to deliver the material in other districts as per MSEDCL requirement. Further outside Maharashtra bidders have to deliver the material as per MSEDCL requirement to the designated consignee.
- ix) MSEDCL on its sole discretion may get material / equipment inspected and tested by third party NABL lab.

#### **5) RIGHT TO CARRY OUT INSPECTION DURING MANUFACTURING:**

The Purchaser at its option, will inspect the material ordered during its process of manufacturing including the inspection of raw materials and will request the supplier to carry out such tests as may be necessary to ensure proper quality of the material. The samples of components of the material shall be subject to quality check by the inspecting officer during manufacturing.

**6) RIGHT TO REVISE DESPATCH INSTRUCTIONS, DELIVERY SCHEDULE AND TO DEFER SUPPLIES:**

- i) The Purchaser reserves its right to revise the dispatch instructions issued along with the order, at the time of giving final clearance for dispatch after inspection of the material. If such change in destination is not intimated at the time of inspection approval or waiver of inspection, the supplier shall dispatch the material as per the dispatch instruction in accordance with A/T. indicated by him in the inspection call letter.
- ii) The Purchaser reserves its right to change the delivery schedule of the contract either by reducing the monthly lot up to 60% of the agreed lot or by increasing the same up to 120% of the agreed lot with prior two months' notice and the Purchaser shall not be liable to pay any compensation/damages on account of such change in delivery schedule.
- iii) The Purchaser reserves its right to defer the balance supply to be received against the order by giving two months' notice for a maximum period of 6 months. In such an event, the delivery period for the deferred material shall be deemed to be extended proportionate to the period of deferment and the Purchaser shall not be liable to pay any compensation/damages on account of such deferment of deliveries.

**7) WAGON LOADS / TRUCK LOADS:**

Quantity to be dispatched to consignee should be minimum in two full truck loads and may be part load as per the Purchaser's requirements may not necessarily be in full wagon load / truck load and may be part load as per the Purchaser's requirement.

**8) ROAD TRANSPORT:**

In case the supplier prefers to dispatch the materials by road transport at his risk and cost and without any extra cost to the Purchaser, the materials shall be accepted only during office hours on working days. The supplier should ensure that the goods reach the stores in first half so as to arrange their unloading during office hours, failing which, the Purchaser shall not be liable for delay in unloading and for inconvenience caused to the transport contractor in the form of detention etc. Unloading at stores will be arranged by the consignee.

**9) DESPATCH INTIMATION:**

The supplier shall inform by e-mail to the consignee details of dispatch along with e-way bill receipt in hard & soft format giving RR / LR No., Wagon / Truck No., Type of wagon, craneable consignment or otherwise, total value of consignment, etc. to facilitate the consignee to arrange for clearance of goods on [cemmcmsedcl@mahadiscom.in](mailto:cemmcmsedcl@mahadiscom.in) or [cemmcmsedcl@gmail.com](mailto:cemmcmsedcl@gmail.com).

**10) BILL OF MATERIALS: (WHEREVER APPLICABLE)**

The supplier shall furnish bill of materials for each type of equipment / material offered which should be consistent with the drawing, specification and guaranteed technical particulars. The copies of the bill of materials should always be enclosed along with the bill submitted by the supplier for payment wherein he should specifically mention the materials / components dispatched out of the bill of materials, if the equipment is not sent in totality. Where the equipment / material to be supplied consist of more than one component, the supplier claiming payment for equipment / materials shall certify that all components of the equipment / material have been supplied in full for the quantity indicated in the invoice. Part payment shall not be allowed.

**11) PACKING LIST:**

Each package shall contain, in waterproof cover, the detailed list indicating the order reference, date, list of content and reference to the approved bill of materials. Each item contained in the package shall be described sufficiently to enable identification of the quantity, weight etc. There should not be any alteration in the packing list incorporated in the order, soft copy of the packing list should be sent to all the consignees and hard copy to G.M. (F&A-SB) should be enclosed with the bills along with other documents.

**12) REPLACEMENT OF GOODS LOST, BROKEN OR DAMAGED:**

Notwithstanding anything herein contained, the supplier undertakes to be responsible for the safe arrival of the materials in good condition and without any loss or damage at the final destination and until the same be actually delivered to and received by the Purchaser at its stores or other place of final destination and for this purpose, materials carried by railways or other carrier shall be deemed to be so carried at the risk of the supplier. In case of transit damage / shortages, the payment shall be made only for the quantity received in good and working condition and the consignee shall lodge claims with carriers and transfer the same to the supplier with all necessary documents for settlement of the same with carriers at the supplier's end. The transit damages / shortages / losses reported by the consignee shall be repaired / replaced by the supplier duly inspected, free of cost, within one month from the date of such intimation of breakages / shortages / losses without waiting for settlement of the claims from carrier or insurance co. etc.

However, rectification of minor defects at store locations are allowed for following minor defects only.

- i. Leakages.
- ii. Bushing replacement
- iii. LA replacement
- iv. Nut bolt tightening etc.

**13) REPLACEMENT OF REJECTED MATERIALS:**

If, on inspection at the final destination, the Purchaser discovers any loss in the materials supplied or that they are received in damaged condition or that in the opinion of the Purchaser, they are not of the contracted quality or specification, the Purchaser shall be entitled (notwithstanding that the property in the materials shall have passed on to the Purchaser) to refuse to accept or reject the materials altogether and claim damages or cancel the contract and buy its requirements from any of its suppliers stipulating earliest possible delivery and in accordance with its tender system against the supplier and recover the damages if any, from the supplier from any outstanding sums that may be due to the supplier from the Purchaser against this contract or against any of the contract entered into with the supplier, without prejudice to other rights and remedies available to it in law and reserving always to itself the right to forfeit the performance deposit placed by the supplier for the due fulfillment of the contract.

In case the stores / materials are found not in accordance with the prescribed specifications and / or the approved sample, the same will be rejected and the supplier shall replace the rejected stores / materials free of cost within one month from the date of intimation. The replacement of goods shall also have to be got inspected as per inspection clause. Further if the stores / equipment supplied becomes incomplete on account of either



rejection or short supply of its components, the complete cost of the stores / equipment shall be recovered from supplier's bills without notice.

#### 14) MATERIAL DESPATCHED AND PROGRAMME:

A statement as under indicating dispatches effected during every month shall be furnished to this office along with the programme of manufacturing / dispatches during the following two months. In the event of no dispatch, the statement shall contain nil information.

##### MONTHLY STATEMENT:

- I. Name of Supplier:
- II. Reporting Month:

Sr. No.	A/T No.	Material	Item No. as Per A/T	Consignee	RR / LR Delivery Challan No. With date	Date of Actual Receipt of Material	Qty. Dispatched Between 26 <sup>th</sup> of Preceding Month and 25 <sup>th</sup> of the Reporting month	Programme of supply during the next 2 months
1	2	3	4	5	6	7	8	9

Consolidated details of the above information shall be furnished to office of the Chief Engineer (M.M. Dept.) after completing the supplies of a particular order. The copy of this consolidated information shall invariably be forwarded to the respective consignees, failing which; security deposit paid against the contract shall not be released.

#### 15) MATERIAL RECEIPT & SUBMISSION OF BILLS AT CONSIGNEE:

On receipt of material at destination of consignee as per DI, Additional Executive Engineer (MM DEPT.) of respective store should ensure the receipt of material in good & healthy condition. While receiving the material, store in charge should ensure the receipt of material as per Dispatch Instructions issued by MM Dept. Further, the store in charge should ensure the receipt of original & scan copies of following documents:

- a) Tax invoice.
- b) Detailed packing list.
- c) Bill of Material.
- d) Delivery challan.
- e) E-way bill receipt.
- f) Dispatch document (RR/LR).

On confirmation & validity of above documents, store in charge will generate Provisional SR Note through ERP system immediately for receipt of material at stores thereof.

Where required by the Purchaser, the successful bidder must send the operation and maintenance manuals, test certificates, drawings etc. for the material ordered. These should be sent immediately after dispatch of material and a statement to that effect should be made in the invoice.

After successful RST of supplied each lot, store in charge will generate final SR note through ERP system immediately from receipt of RST report at stores.

**16) PAYMENT OF BILLS:****(a) Terms of payment:**

- a. The Bidder shall be paid 100% payment within 60 days from the date of receipt of material in good condition, against Stores Receipt Notes (S.R. Notes) issued by the concerned consignee.
- b. However, in respect of only those entities which qualify for 45 days payment period under the Micro, Small and Medium Enterprises Development Act, 2006, 100% payment of the Contract price will be paid within 45 days from the date of receipt of material at Consignee Store in good condition, against Stores Receipt Notes (S.R. Notes) issued by the concerned consignee.
- c. In respect of Micro, Small and Medium Enterprises, best efforts will be made for payment within 45 days from date of submission of invoice along with requisite documents after the delivery of entire lot. However, no claim for interest will be entertained in case of delay in payment beyond 45 days. The Micro, Small and Medium Enterprises who are ready to accept this payment term may only quote. No dispute in this regard will be entertained. After completion of order, the claims of whatsoever nature lodged after 30 days from the last date of payment will not be entertained.
- d. The payment shall be effected by A/C payee cheques / RTGS. Following documents as required in terms of order, will have to be forwarded to the G.M. (F&A-SB), Maharashtra State Electricity Distribution Co. Ltd., Prakashgad, Station Road, Bandra (East), Mumbai - 400 051 along with bills in triplicate to facilitate payment with a copy to the Chief Engineer of respective Zone.
  - (i) Invoice (on the basis of rates accepted as per A/T) issued in accordance with the provisions of GST Invoice Rules.
  - (ii) Inspection and Test Certificate approval.
  - (iii) E Way Bill
  - (iv) Copy of Acceptance letter of Permanent Bank Guarantee / Security Deposit Certificate.
  - (v) Packing list.
  - (vi) Approved Bill of Material.
  - (vii) Certificate of having dispatched Operation & Maintenance Manual, copies of Test Certificates and approved drawings / Bill of Material to consignees wherever applicable.

The supplier shall forward the original R.R. / L.R. direct to the consignee along with relevant documents. The original bill shall be forwarded to The G.M. (F&A-SB), MSEDCCL, Prakashgad, Bandra (E) and marked ORIGINAL. The bill should indicate the GST registration no. and date held by him under the GST Law. The Purchaser shall not be responsible for delay in payment of bills if the supplier fails to comply with any of the above requirements.

Supplier's copy of S.R. Note will be forwarded by the consignees through their respective Common Stores for supplier's record towards acknowledgement of receipt of material. Accounts copy of S.R. Note will be forwarded by the respective Common Stores to G.M. (F&A-SB) for payment.

Wherever the payment is to be effected against Material Receipt Intimation (MRI) and if the supplier fails to forward the documents such as inspection report, bill of materials, approved drawings, etc. wherever required along with the invoice to the respective consignees and no payment shall be made against the said MRI.

The whole of the first lot as well as monthly lot when delivered in installments, the date of delivery and due date of payment will be counted after the receipt of the entire lot.

Any amount more than Rs. One Lakh can be transferred to the bank Account of the supplier electronically. For this RTGS (Real Time Gross Settlement) provision, following information is to be furnished by the bidder in the required documents of the online offer.

1. Name of the Company
2. Name of the Bank & Branch with address where the amount is to be transferred.
3. Current Account Number (15 digits)
4. RTGS No. / (IFSC Code ) ( Indian Financial Security Code)
5. MICR Code of the Bank
6. Company's email ID
7. Contact Name & Telephone No.

**17) TAXES:**

(A) Notwithstanding the fact that contract price is inclusive of GST:

- (i) GST shall be paid at actual on the basis of due date of delivery or actual date of supply whichever is lower against documentary evidence.
- (ii) Variation in GST on bought out items shall not be entertained.

(B) Structural changes in and due to 'Input Tax Credit' Scheme: -

- (i) In the event of any structural change occurred in the Input Tax Credit Scheme after the date of submission of the tender till the currency of the contract, the benefit out of such change shall be passed on to the purchaser.
- (ii) In the event of 'Input Tax Credit' being extended by the GST Law which were otherwise ineligible for claiming Input tax credit thereof, the seller should advise the purchaser about the additional benefits accrued or any variation thereof, through a letter containing such details and computation within such time as may be agreed between both the parties i.e. Supplier & MSEDCL.

**18) DEDUCTION:**

Any amount or amounts which become payable by the supplier to the purchaser under a particular contract, shall be deducted by the purchaser from any amount/amounts due or becoming due to the supplier under the same or any other contract and shall be adjusted against dues to the Purchaser.

**19) GUARANTEE:**

Material offered shall be guaranteed for a period 66 months from the date of receipt at the consignee's Stores Center or 60 months from the date of commissioning, whichever is earlier. In case of failure of material within the above guarantee period, tenderer shall make available other new conditioned / repaired material / equipment, free of cost at Division / Stores / Site for replacement within 45 days from the date of intimation from Division filter unit / Stores and lift the failed material / equipment for repair rejected material after replacement. For this purpose, bidder shall maintain spare stock in adequate quantity of ordered ratings of material / equipment. If the defective material is not replaced / repaired within the specified period as above, the Maharashtra State Electricity Distribution Company Ltd. shall retain an equivalent end cost of material plus 15% supervision charges from any of the bills of the supplier or encashing available performance bank guarantee submitted against guarantee period or through any available sources, till the return of the equipment. No interest will be paid on the amount so retained / recovered. In case of material / item not returned duly repaired within 45 days, penalty shall be imposed @ 0.5% per week or part thereof maximum up to 10% of the cost of undelivered material / equipment beyond specified time limit. In case of material / item not returned duly repaired within 5 months, total cost of the material / item along with penalty will be adjusted / recovered from the pending bills of the supplier or encashing available performance bank guarantee submitted against guarantee period or through any available sources with MSEDCL.

The guarantee period failed material / equipment will be made available at MSEDCL filter unit / Site. Loading and unloading of guarantee period failed material / equipment should be arranged by the supplier.

The clause itself shall be the notice to the supplier about encashment of PBG to adhere to the timelines.

The outage period, i.e. the period from the date of failure till unit is repaired / replaced shall not be counted for arriving at the guarantee period. Thus supplier has to extend the guarantee period by outage period.

Further, in case of repeated failures of equipment / material, the Purchaser reserves the right to debar / disqualify the supplier for future tenders / orders.

**20) LIFTING OF MATERIALS:****A) LIFTING OF REJECTED/DAMAGED MATERIALS FROM STORES:**

- (a) On failure to replace or repair the transit damaged or rejected material within one month from the date of intimation as required under tender, it shall be deemed to have concluded that such material is finally rejected. The damaged / rejected material shall be lifted by the supplier within 30 days from the date of receipt of notice to that effect from the concerned consignee on reimbursement to the Purchaser of the cost of the material / equipment, if any, already paid in terms of payment clause in the contract and actual expenses incurred by the consignee towards handling, demurrage / wharfage / undercharges, freight, insurance premium etc. The Purchaser shall not be responsible in any case for the loss, destruction, damage, deterioration of the material after expiry of the said 30 days period.

- (b) If the supplier fails to lift the material within this period, the material will remain with the Purchaser at the cost and risk of the supplier. Supplier shall, therefore, be liable to pay ground rent @ 0.1% (Plus GST as may be applicable) per day of purchase cost of the material to be lifted from the date of intimation of rejection till the actual date of lifting.
- (c) The Purchaser will give 7 days' notice for lifting of rejected material and if not lifted, will be also free to Scrap / dispose of such material, after the period of said 37 days, by Public auction/Tender notice/Destruction as may be deemed fit and storage charges @ 0.1 % (Plus GST as may be applicable) per day of purchase cost will be recovered from the date of intimation of rejection of materials till the date of realization of the sale amount/physical removal of the material besides the actual expenses incurred as referred to at (a) above. The amount received from the sale of scrap/rejected material will be adjusted in the penalty.

Notwithstanding what is contended in the foregoing clauses, the supplier shall be liable to pay the Purchaser the cost and expenses incurred by the Purchaser, if any, including ground rent and the same shall be appropriated and recovered from the sale proceeds.

**B) LIFTING OF FAILED MATERIAL / EQUIPMENT FROM DIVISION FILTER UNIT / SITE (If Applicable) :**

- a) If the supplier fails to lift the failed material within specified period, the material will remain with the Purchaser at the cost and risk of the supplier (By recovering end cost of failed transformer). The Purchaser will be also free to dispose of such material, after the period of 5 months from the date of intimation of failure by Public auction / Tender notice / Destruction as may be deemed fit or repaired departmentally and recovered cost will not be refunded to supplier.
- b) Process for lifting of rejected / damaged / failed materials from Divisions / Stores / Site:
- i. The communication / correspondence shall only be made by specified e-mail id [cemmcmsedcl@gmail.com](mailto:cemmcmsedcl@gmail.com) by MSEDCL field offices / the supplier.
  - ii. As soon as the material/equipment is failed within guarantee period, the concerned Executive Engineer of O&M Division / Stores-in-charge shall inform the intimation of such failure immediately to Supplier as well as Material Management Department, Head Office on specified e-mail id in Format A (failure report).
  - iii. The Material Management Department will forward the format A to SB Section, Head office to withhold the payment equivalent to the cost of material/equipment with 15% supervision Charges from any of the bills of the supplier. If the supplier fails to return repaired transformer at concern O&M Division / Store within 45 days from the date of intimation, penalty to be imposed @ 0.5% per week or part thereof maximum up to 10%.
  - iv. On receipt of material/equipment against replacement or repairs, the Executive Engineer, O&M Division / Store-in-charge will issue Format C (Rectification report) to concern supplier with copy to Material Management Department Head Office through specified e-mail id.
  - v. The supplier shall note that the guarantee period for the delayed period taken for replacement / repairing of material/equipment will be automatically extended.

- vi. Material Management Department Head Office shall inform the SB Section, Head office to release the payment withheld against that material/equipment.
- vii. From the date of intimation, if supplier fails to return repaired material/equipment at O&M Division / concern store within 5 months, concerned Executive Engineer of O & M Division / Stores-in-charge shall inform the intimation of such failure immediately to Material Management Department, Head Office on specified e-mail id.
- viii. The Material Management Department Head Office shall forward the same to SB Section, Head office to recover the payment equivalent to the cost of material/equipment from any of the bills of the supplier with penalty to be imposed @ 0.5% per week or part thereof maximum up to 10% for final recovery as per clause 19.

**21) LIQUIDATED DAMAGES FOR LATE DELIVERY:**

In case the materials are not delivered within the period stipulated in the order, the supplier shall be liable to pay at the discretion of the competent authority of the Purchaser, the liquidated damages to the Purchaser @ 1% per week or part of week on the value of delayed material / unexecuted quantity plus taxes as applicable, if any on the price subject to a maximum of cumulative ceiling of 10% reckoned on the contract value of such complete portion or section of the plant, equipment or material delayed and also the portion supplied which could not be brought into commission due to any part thereof not having been delivered in time. In addition to above if bidder fails to supply the material within contractual delivery period continuously for 3 lots, then the order shall be liable for cancellation.

Due consideration may be given in the levy of liquidated damages for reasons absolutely beyond the control of the supplier, for which documentary evidence shall be produced to the satisfaction of the competent authority of the Purchaser.

The Purchaser shall be entitled to deduct/recover the amount of liquidated damages from the current bill payable to the supplier or any other amount due or payable to him against this or any other contract.

For computing the liquidated damages for delayed supplies, the date of railway receipt or the date of receipt of materials at stores in case of road transport, shall be the date of delivery.

In case the Purchaser does not arrange for inspection of material within 10 days from the date of receipt of inspection call to MSEDCL wherever applicable, the period of more than 10 days till inspection will not be considered for levy of liquidated damages. For computing the period taken for inspection in such cases, the relevant date mentioned in the inspection certificate issued by the inspecting officer would be considered.

**22) ORDER PLACED ON TIME PREFERENCE BASIS (WHEREVER APPLICABLE):**

In case of order on time preference basis (i.e. orders given at higher rate on delivery period considerations only) if order is given at higher rate of L-2 (or L-3 etc.), then the payment at higher rates will be made provided the firm makes supplies within the stipulated time period. In case of delay in supplies, the payment will be made at the rates offered by L-1. In addition, Clause No.21 above for Liquidated Damages for late delivery will also be applicable. However, the quantity allocation for order under this clause shall be at the sole discretion of MSEDCL & the specified quantity allocation for this tender will not be applicable in this case.

**23) FORCE MAJEURE CLAUSE:**

If, at any time, during the continuance of this contract the performance in whole or in part by either party of any obligation under this contract shall be prevented or delayed by reason of any war, hostility, acts of the public enemy, civil commotion, sabotage, fires, floods, explosions, epidemics, quarantine restriction, strikes, lock-outs or acts of God (herein after referred to as "events"), provided notice of happening of any such eventuality is given by either party to the other within 21 days from the date of occurrence thereof, neither party shall by reason of such event, be entitled to terminate this contract nor shall either party have any claim for damages against the other in respect of such non-performance or delay in performance; and deliveries under the contract shall be resumed as soon as practicable after such event has come to an end or ceased to exist, and the decision of the purchasing officer as to whether the deliveries have been so resumed or not, shall be final and conclusive, provided further that if the performance in whole or part of any obligation under this contract is prevented or delayed by reason of any such event for a period exceeding 60 days, either party may at its option terminate the contract PROVIDED ALSO that if the contract is terminated under this clause, the purchaser shall be at liberty take over from the contract at a price to be fixed by the purchasing Officer which shall be final all unused, undamaged and acceptable materials, bought out components and stores in course of manufacture in the possession of the contractor at the time of such termination or such portion thereof as the purchaser may deem fit accepting such material, bought out components and stores as the contractor may with the concurrence of the purchaser elect to retain.

**24) ACCEPTANCE OF LOWER FORD RATE OFFERED IN SUBSEQUENT TENDER :**

During contractual delivery period of supply, the quoted rates shall remain the same, however for same specification of material if the rates will receive lower in another subsequent tender in extended period of contract then it is binding on the supplier to supply the same material at lower rate for balance quantity of material i.e. in case if price bid of next subsequent tender of similar technical specification is opened and FORD rate found lower than the ongoing contracts this FORD rate shall be made applicable for the balance quantity beyond contractual delivery period. Further the purchaser reserves the right to allow the supplier to deliver the quantity or otherwise beyond the contractual delivery period.

However other stipulations of clause No. 23 of Section-II i.e. Annexure-A will remain unchanged.

**25) PERFORMANCE OF CONTRACT:**

The Purchaser will not be in any way liable for non-performance either in whole or in part of any contract or for any delay in performance thereof in consequence of strikes, shortage, non-availability of raw materials, combination of labour or workmen or lockout, breakdown or accident to machinery or accidents of whatever nature, failure on the part of the railways to supply sufficient wagons to carry essential raw materials etc. and finished products from the stores, subject to the provision and stipulation made in condition No. 21 as stated above i.e. Liquidated damages for late delivery.

**26) CONTRACT PERFORMANCE DEPOSIT:**

- a) The supplier will have to furnish contract performance deposit as per Annexure - N in the form of unconditional & irrevocable BG within 15 days from the date of issue of LoA.
- b) The contract performance deposit shall be an amount equal to 5% of the contract value and shall be valid for a period of 90 days beyond guarantee period of the last lot of the equipment supplied.

- c) The contract performance deposit shall be refunded within 90 days from the date of expiry of the guarantee period of the equipment supplied. The purchaser shall not be liable to pay any interest or compensation to the contractor for retaining the deposit after the end of the said period.
- d) The contract performance deposit is intended to secure the performance of the contract for guarantee period of the equipment supplied. However, it is not to be construed as limiting the damages stipulated in other clauses of the contract.

**27) POWER OF ATTORNEY:**

It will be obligatory on the supplier to communicate the revocation of Power of Attorney, if any, after submission of offer till the execution of contract failing which the act/s & action done by the agent / representative shall be deemed to be the valid act/s & action of the bidder / supplier.

**28) SETTLEMENT OF DISPUTE:**

Permanent Dispute Resolution Committee (PDRC) comprises of Chief Engineer (MM Dept.), one member of Accounts Department and representative of supplier will resolve the dispute arise if any.

**29) JURISDICTION:**

Any disputes or difference arising under, out of or in connection with this tender or contract if concluded, shall be subject to the exclusive jurisdiction of the "Courts" in Mumbai.

**30) TERMINATION OF CONTRACT**

- 1) The decision of the Purchaser shall be final as regards the acceptability of the stores supplied by the supplier and the Purchaser shall not be required to give any reason in writing or otherwise at any time for the rejection of the stores/materials.
- 2) In case the contractor/supplier fails to deliver the stores/material or any consignment thereof within the contracted period of delivery as per delivery schedule or in case the stores/materials are found not in accordance with the prescribed specification and the performance of the supplied material is not found satisfactory, the Purchaser shall exercise in discretionary power either,
  - a) To purchase from elsewhere, after giving 15 days due notice to the contractor, at the risk of contractor, such stores/material not so delivered or other of similar description, without cancelling the contract in respect of consignment not yet due for delivery,
  - OR
  - b) To cancel the contract reserving Purchaser's right to recover damages Plus GST as may be applicable.
  - c) notwithstanding that the powers under (a) and (b) referred above are in addition to the rights and remedy available to the Purchaser under the General Law of India relating to contract.
  - d) Purchaser reserves right to recover damages against risk purchase or 10% value of non-supplied material plus applicable taxes, if any whichever is higher.

In the event of risk purchase of stores of similar description, the option of the Purchaser shall be final. In the event of action taken under (a) or (b) above, the



supplier shall be liable for any loss which the Purchaser may sustain on that account but the supplier shall not be entitled to any saving on such purchases made against default.

3) Further contract can be terminated in case of sub-standard /poor quality material.

**31) DEBAR / BLACKLISTING OF MANUFACTURER:**

In the event of fraudulent practices / non-compliance / non fulfillment of any obligation as required by MSEDCL at any stage of tendering or execution, the bidder is liable to be debarred / blacklisted at the discretion of MSEDCL.

**32) TAX DEDUCTED AT SOURCE:**

The purchaser shall deduct tax at source in accordance with the provisions of the laws as and when the same is notified.

## SECTION-III

### I. Quantity procurement :

The quantity for procurement is as below.

Sr. No.	Item code	Item description	Unit	Tender quantity in nos.	Estimated cost of tender (Crores)
1	85000803713	33 KV/ 11 KV, 5 MVA Power Transformer	No	219	110.02
2	85000804273	33 KV/ 11 KV, 10 MVA Power Transformer (with NIFP system)	No	181	164.33
Total					274.35

### II. Qualifying Requirements:

1. The bidder shall be an Original Equipment Manufacturer (OEM).

Upload:

- a) UDYAM Aadhar / Company Incorporation Certificate, etc.

2. The bidder should have experience for supply of similar or higher rating of material / equipment to any Electricity Distribution Utility, Electricity Distribution Franchisee or Public Sector Undertaking and should have executed orders of 30% of tender quantity for offered item during last three financial years.

Bidders who supplied the material in MSEDCLs projects viz; INFRA - II, IPDS, DDUGJY, DPDC, DDF, Non DDF, HVDS or any other scheme shall also be considered & bidder shall produce the order completion / quantity supplied certificate from concern Superintending Engineer (Infra/O&M).

Upload:

- a) Copies of orders executed by the bidder and the Certificate from the purchaser with regards to successful execution of the order / supply of quantity for preceding three financial years.

- b) List of orders in hand.

3. For all tendered material, valid Type test certificates (If applicable) as per MSEDCLs technical specifications (Annexure-D) which are carried out within 5 years prior to the date of opening of tender from NABL accredited lab such as CPRI / ERDA shall be uploaded in the bid. Bids without the Type test certificates shall not be considered for further evaluation.

Upload:

- a) Type test certificates from NABL accredited lab such as CPRI/ERDA valid for a period of five years.

4. Average Annual Turnover – The Average annual turnover of last three financial years of the bidder shall be 30% of the tender estimated cost of offered quantity. The bidder has to submit the annual turnover certificate of the company of last three financial years duly certified by Chartered Accountant.

Upload:

- a) Documentary evidence showing annual turnover of last 3 years, certified by Chartered Accountant for preceding three financial years. (As per attached Format-4)
5. The bidder should have in-house testing facilities for conducting acceptance & routine tests in accordance with the procedures laid down in relevant IS /IEC amended up to date.

Upload:

- a) List of in house manufacturing and testing facilities as well as quality control set up.
6. The bidder shall have ISO certification for quantity management system & environmental management system.

Upload:

- a) ISO for quantity management system.
  - b) ISO for environmental management system.
7. Following Documents should be submitted by the bidder along with the bid.

Upload:

- a) Documentary evidence (for e.g. Udyam Registration/NSIC/Chartered Accountant/Engineer Certificate) for manufacturing capacity to cover the quantity offered by the bidder and considering orders in hand.
- b) Certificate from Chartered Accountant for not having controlling stake in more than one entity as per attached Format-3.
- c) Annexure-F regarding declaration of legal litigations.
- d) Annexure-I regarding debar undertaking.
- e) Self-undertaking on bidders letter head for not approaching any one for undue influence as per attached Format-2.
- f) GST registration certificate.
- g) EMD receipt (Bank Guarantee or Demand Draft)
- h) Power of attorney.
- i) Certificate for No Deviation as per attached Format-5.

**ANNEXURE - "B"**

**QUANTITY, PRICE AND DELIVERY PERIOD**

**ANNEXURE - "B" to be submitted online against commercial bid; attached separately**

**ANNEXURE 'C-1'**

**[To be submitted later on as per as per Clause XVIII (B) of Instructions]**  
CONFIRMATION FOR ACCEPTING ORDER BY MATCHING RATES WITH LOWEST  
ACCEPTABLE BIDDER

**APPLICABLE FOR INDUSTRIAL UNITS FROM MAHARASHTRA ONLY** Marketing Assistance and Purchase Preference to the units from Maharashtra (refer Clause XVIII of Instructions to Bidders):-

1. In case your unit is located in Maharashtra and the  
**(a)** lowest acceptable rate received against the tender is from the unit outside Maharashtra, please confirm whether you are agreeable to accept order at that lowest acceptable rate limited to 50% (fifty percent) of our requirement. ....

**APPLICABLE FOR ALL BIDDERS INCLUDING THOSE ELIGIBLE UNDER THE ABOVE CLAUSES:**

1. Please confirm whether you are agreeable to accept  
**(b)** order at the lowest acceptable rate received against the tender. ....

[Industrial units from Maharashtra can give option under 1(b) above for balance quantity]

Note:-

1. If the bidder gives the above confirmation for the quantity less than as indicated in Clause X (iii) of the Instructions to the Bidders, then the above confirmation shall not be acceptable.
2. Bidders may confirm matching for one or more items originally tendered.
3. Any withdrawal of confirmation for order by matching rate within validity of offer will render the entire offer invalid and shall be summarily rejected and Earnest Money Deposit shall stand forfeited.
4. A bidder will not be entitled to the benefit of offers by matching rates and will not be considered for orders if his original offer is rejected on the ground of ambiguity or because of not accepting /noncompliance of the terms & conditions of the tender.
5. In the above confirmation, if the bidder indicates any rate, then the above confirmation given by the bidder will not be considered as valid.

**ANNEXURE- 'D'**

TECHNICAL SPECIFICATION

As Indicated in E-Tendering

**ANNEXURE-E**

CONSENT FOR MSEDCL STANDARD TECHNICAL SPECIFICATIONS & GTP

**Not Applicable**

**ANNEXURE-F**

(On supplier's Letter Head)

I, ..... certify that,

The business dealings with our firm / agency M/s..... and its sister concern/Director/Partner/Proprietor have no any type of legal litigation against MSEDCL is pending in any court/Forum against/by the bidder or its sister concern/Director/Partner/Proprietor.

If it is found at any stage of tendering and order execution process then as per the tender conditions our offer will be rejected and I /We don't have any objection on the same.

I hereby certify that I am duly authorized representative of M/s.----- whose name appears above my signature.

Bidders Name:

Authorized representative's signature:

Authorized representative's Name:

Seal of the company

Name and address of the Bidder

Date:



**ANNEXURE -G**

**PRICE VARIATION CLAUSE**

**Not Applicable**

**ANNEXURE - H**

**GUARANTEED TECHNICAL PARTICULARS**

As indicated in E-Tendering GTP Parameter

**ANNEXURE - I**

(On supplier's Letter Head)

I, ..... certify that,

- a. The business dealings with our firm / agency M/s..... have not been debarred by any Ministry of GoI / GoM / state owned electricity distribution utility and still in force.
  
- b. The Directors, Proprietors, Partners, Employee(s) or owner of our firm / agency M/s..... have not been either jointly or severally guilty of malpractices in relation to its business dealings with the Government or MSEDCL during the last five years.

I hereby certify that I am duly authorized representative of M/s.-----  
whose name appears above my signature.

Bidders Name:

Authorized representative's signature:

Authorized representative's Name:

Seal of the company

Name and address of the Bidder

Date:

ANNEXURE - J

(On MSEDCL Letter Head)

Dispatch Instructions

BY R. P. A. D. / ORD. POST /E-MAIL

(SAP CONTRACT No: -----)

To,

M/s. -----

Email: -----

Sub: Supply of ----- against A/T No. ----- dt. -----

Ref: Final Inspection Call letter No. ----- dt. -----.

(I.W. Regn. No. ----- dt. -----)

Your readiness of material letter no. .... dtd.....

Dear Sir,

With reference to the above, you are requested to dispatch ..... transformers as given below:

Sr. No.	Consigned to	Meant for Circle	Meant for Zone	Qty. in Nos.

Further, you are requested to contact concerned S.E. (O&M) Circle / E.E. (O&M) Division / Addl. E.E. (MM Section) before dispatching / unloading the above material.

This is issued without prejudice to all other terms and conditions of the order.

Yours Sincerely,

Chief Engineer (M M Dept.)

Copy f.w.cs.to: The C.E., MSEDCL, -----.

Copy to:

The G.M. (F & A – SB), MSEDCL, Mumbai.

The E.E. (IW), MSEDCL, Mumbai.

The E.E. (O & M Division), MSEDCL, -----

The Addl.E.E. (MM Section), MSEDCL, -----

## ANNEXURE - K

## List of Stores

Sr. No.	Name of Stores	Address
1	Common Stores Ahmednagar	Nagar-Pune Road, Opp. Arti Hotel, Kedgaon, Ahmednagar.
2	Common Stores Airoli	Power House, Thane-Belapur Road, Airoli, Navi Mumbai.
3	Common Stores Akola	Major Store Babhulgaon NH No 6 Akola.
4	Common Stores Amravati	Major Store MSEDCL Power House, Mulshi Road, Amravati.
5	Common Stores Chhatrapati Sambhajinagar	MIDC Plot No. J-13, Opp. Garware Stadium, Naregaon Phata, Chikhalthana, Chhatrapati Sambhajinagar.
6	Common Stores Beed	Near 132 kV Sub-station, Idgah Nagar, Nalvandi Naka, Beed.
7	Common Stores Chandrapur	Near Vidyut Bhavan, Bagala Chaowk, Babu Peth, Chandrapur.
8	Common Stores Jalgaon	Old MIDC Area, Behind Ajanta Lawns, Ajanta Road, Aurangabad Highway, Jalgaon.
9	Common Stores Kalyan (Netivali)	MIDC Phase 1, Near Tata Power House, Kalyan - Dombivali Road.
10	Common Stores Kamptee	Maldhakka Godown, Behind Railway Station Kamatee, Nagpur.
11	Common Stores Khamgaon	Manav Dharm Bld. Near 132 kV Sub-Station, Shegaon Road, Khamgaon, Dist. Buldhana.
12	Common Stores Kolhapur	Kaneri Math Road, A/P Gokulshirgaon, Tal. Karveer, Dist. Kolhapur.
13	Common Stores Kudal	Malwan Road, MIDC Pinguli-Nerur, Kudal, Sidhudurg.
14	Common Stores Latur	MIDC Plot No. P-21/P, In Front of Kirti Gold Oil Mill, Latur.
15	Common Stores Mulshi	Phursungi-Saswad Road, Near Overhead Bridge, Mulshi/ Phursungi, Dist. Pune.
16	Common Stores Nanded	Taroda Naka Main Road, Nanded.
17	Common Stores Nashik	Aringale Plot, Hanuman Nagar, Jail Road, JunaSaykheda Road, Panchak, Nasik.
18	Common Stores Dharashiv	Near MSEDCL Rest House, Tuljapur Road, Dharashiv.
19	Common Stores Palghar	Near 33/11 kV Sub-Station, MSEB Coloney, Boisar Road, Palghar.
20	Common Stores Parabhani	Old Power House Jintur Road, Parbhani.
21	Common Stores Ratnagiri	MIDC Area Mirjole, Kuwarbav, Ratnagiri.
22	Common Stores Sangli	Near Walchand Engineering College, VishramBaug, Sangli.
23	Common Stores Satara	A/P Satara, Tal. Koregaon, Dist. Satara.
24	Common Stores Solapur	Plot No P-4, MIDC Chincholi, Behind Post Office, Solapur
25	Common Stores Tumsar	Near Power House, Nakaq Dongari Road, Old Bus Stop, Tumser, Bhandara.
26	Common Stores Yavatmal	MIDC Lohara, Yavatmal.

ANNEXURE – L

Format for Inspection Call Readiness of Material

Ref. No.

Date:

To,  
The CE (MMD),  
Prakashgad, Bandra (E),  
Mumbai - 400051.

**Sub:** Inspection Readiness of material against A/T No. ----- dated. ----- for  
Supply of -----.

-----

1. Brief description of the material Offered for inspection:
2. Reference of drawing Approval :
3. a) Reference of approval of type test:  
b) Reference of approval of balance type test (If applicable):
4. Whether it is a joint inspection with Testing SE (TQA) etc. (if applicable):
5. a) Whether Performance Deposit has been paid against the order:  
b) if paid, please give details:
6. Sr. No. of the items as per A/T:
7. Total Quantity of the items Ordered:
8. Total quantity of the items inspected so far:
9. a) Quantity monthly committed in delivery schedule:  
b) Lot No. for which the Quantity is offered for inspection now:  
c) Due date of delivery as per A/T for offered quantity:
10. Date of readiness of Material:
11. Complete address of the factory where materials is to be inspected:
12. Name of the person to be contacted in connection with inspection & his  
Office/Factory/Residence Tel. No.:
13. Staggering holiday of Factory/Office at the place of inspection:
14. a) Whether Dispatch Instructions are available (Say Yes or No):  
b) Quote Letter No.:  
c) Brief destination & Qty. per consignee of this present lot offered:
15. Last visit of our Inspecting Officer:
16. a) Whether the entire material is dispatched against last inspection. (Our EE[IW]  
will ensure before inspection of this lot that the earlier inspected lot is already  
dispatched)  
b) Quantity dispatched
17. Further programme of production Quantity likely to be offered & by what date:

Authorized Signature  
For (Name of the Firm).

ANNEXURE – M

BANK GUARANTEE FORMAT

**EARNEST MONEY DEPOSIT BANK GUARANTEE AGAINST TENDER**

B.G. No. & DATE:

The Bank of \_\_\_\_\_(full address of Branch) hereby agree unequivocally and unconditionally to pay, at Mumbai within 48 hours, on demand in writing from the MAHARASHTRA STATE ELECTRICITY DISTRIBUTUION CO. LTD. (name of the company formerly known as M.S.E.B.) on behalf of M/s \_\_\_\_\_(Address as per MSEDCL REGISTRATION) who have tendered and/or contracted or may tender or contract hereafter for supply of materials. Equipments or services to the MAHARASHTRA STATE ELECTRICITY DISTRIBUTUION CO. LTD. against Tender No. ----- dated ----- total value of Tender is Rs. -----

This agreement shall be valid and binding on this Bank up to and including validity (date) and shall not be terminable by notice or any change in the constitution of the Bank or the firm of contractors or any other reasons whatsoever and our liability hereunder shall not be impaired or discharged by any extension of time or variations or alternations made given conceded or agreed with or without our knowledge or consent by or between parties to the said within written contract. The validity of this Bank Guarantee will be extended by us for the further period of six months, one month prior to its present validity period at the request of MAHARASHTRA STATE ELECTRICITY DISTRIBUTUION CO. LTD.(name of the company-formerly known as M.S.E.B.).

In case of any dispute arising out or it connection with the extension or encashment of Bank Guarantee, the Courts in Mumbai will have jurisdiction.

Our liability under this Guarantee is restricted to Rs.-----/- (Rupees----- only). Our Guarantee shall remain in force until (date). Unless a suit or action to enforce a claim under the guarantee is filed against us within six months from the aforesaid date, all your rights under the said guarantee shall be forfeited and we shall be relieved and discharged from all liability there under.

Place:

Date:

Sign-----

For-----

(Banker’s Rubber Seal & Bank Code No. of signatory)

Please note that:

1. The value of non-judicial stamp paper for this Bank Guarantee is Rs.200/- should be purchased in the name of Guarantor Bank.
2. The Bank Guarantee should be furnished from any Scheduled Bank/Nationalized Bank.
3. Please state the full and complete postal address of the Bank undertaken the guarantee.
4. The Bank Guarantee may be valid as per terms and condition of A.T.
5. B.G. should be submitted along with covering letter of Bank.

ANNEXURE – N

**BANK GUARANTEE FORMAT**

**FORM OF BANK GUARANTEE FOR THE PERFORMANCE OF THE EQUIPMENT**

B.G. No.& Date:

This deed of Guarantee is made this .....day of.....  
By.....branch having at H.O. at..... (here in after called “the Surety” which expression shall where the context so admits include its permitted assign ) in favour of MAHARASHTRA STATE ELECTRICITY DISTRIBUTUION COMPANY LTD. (name of the company formerly known as M.S.E.B. ) being a government company formed as per the provisions of the Maharashtra Electricity Reforms Transfer Scheme. 2005 having its registration no. U40109 MH 2005 SGC 153645 (here in after called the “Creditor” which expression shall include its permitted assigns). WHERE AS M/s. (Name of Party)..... (Postal address as per A/T) have entered into a contract to supply (Name of Material) to the MAHARASHTRA STATE ELECTRICITY DISTRIBUTUION COMPANY LTD. (Name of the Company formerly known as M.S.E.B.). vide contract No. ....dtd.....on the terms and conditions in the said contract. (here in after for brevity sake called “the said contract”).

In accordance with terms of the said contract, the creditor has agreed to pay to M/s.....(Name of Party)..... the said sum representing the 5% of the total contract price for the Rs...../- and WHEREAS M/s. .... (Name of Party).....is required under the terms of contract to furnish a Bank Guarantee for Rs...../- (Rupees:.....Only) the said sum representing the 5 % .....price as given in the said contract.

The surety as he requests of M/s. ....(Name of Party).... has agreed to give this guarantee.

NOW THEREFORE THIS DEED WITNESS AS FOLLOWS:

1. In consideration of the creditor agreeing to make to the debtor at Mumbai the payment of Rs..... (Rupees.....only) being the value of 10% of the total contract .....price as given in the said contract on supplying the complete material as per the contract by the debtor failing which the surety does undertake to pay to the creditor on demand such amount of amounts as the surety may be called upon to pay not exceeding in the aggregate sum of Rs. ..../- (Rupees.....only).
2. The surety hereby guarantee to the creditor the due performance and observance by the debtor of the terms and conditions of the contract.
3. The surety also agrees that it shall not during the currency of the guarantee herein given or during the period of its execution revoke the same even by giving notice to the creditor.
4. On account of the non-fulfillment of the contractual obligation by the debtor or in case the surety or contractor do not renew this guarantee bond as herein provided, the surety will on simple demand from the creditor, pay at Mumbai the creditor, the sum of Rs.....(Rupees ..... only) as indicated under clause -1 above, without demure and without the creditor to invoke any legal remedy that may be available to them to compel the surety to pay the same even if the debtor consider such demand of the creditor unjustified.
5. The surety agrees and declares that notwithstanding anything contained in Section 133 to 135 of the Indian Contract Act 1872 (IX of 1972) or any other rule of law or equity in the view of any variance in the terms of the said contract shall not operate as a discharge of



his obligations hereunder or shall any composition made by the creditor with debtor in respect of any breach of the terms and conditions of the said contract operate as a discharge of the surety's obligation and surety further expressly agrees and declares that though as between the creditor and surety, the surety shall be liable for sum payable or falling due hereunder equally with the debtor and the surety save as otherwise herein provided hereby waives all his rights which he might as guarantor be entitled to claim and enforce.

6. The decision of the creditor that any sum has become payable shall be final and binding on the surety.
7. The guarantee shall come into force on supply of material shall remain in force till the end of .....(date) ....The surety, at the request of the creditor shall extend the validity of the Bank Guarantee for a further period of 12 months, one month prior to its present validity period.
8. In case of any dispute arising out of or in connection with the extension or encashment of the Bank Guarantee, the courts in Mumbai will have the jurisdiction.
9. The guarantee herein contained shall not be effected, by the change in the constitution of the surety or the debtor.
10. Our liability under this guarantee is restricted to Rs. ....(Rupees.....only) and our guarantee shall remain in force until (Date....) unless a claim under this guarantee is lodged with us within six months from the date of expiry of guarantee i.e. on or before ..(date)...all your rights under this guarantee shall be forfeited and we shall be relieved and discharged from all our liabilities there under.

IN WITNESS WHERE OF THE surety has executed this deed in presence of

Place: Signature.....

Date: for.....

(Banker's Rubber Seal & Code No. of signatory)

Witnessed (2 witness is required from bank only)

1) Name & Address

Signature

2) Name & Address

Signature

Please Note:

1. The value of non-judicial stamp paper for this bank guarantee is Rs. 200/- should be purchased in the name of Guaranteed Bank.
2. The bank guarantee should be furnished from any Scheduled bank
3. Please state the full and complete postal address of the bank undertaking the guarantee.
4. B.G. may be valid as per terms of A/T including guarantee period of material.
5. B.G. should be submitted along with covering letter of Bank.

**FORMAT 1**

**ANNEXURE – U-I**

**“INDEMNITY BOND”**

UNDERTAKING TO BE SUBMITTED BY THE PARENT COMPANY SITUATED ABROAD IN CASE OF THE PARTICIPANT BIDDER WHO IS AN INDIAN BASED SUBSIDIARY ON GENERAL STAMP OF `200.00.

The Chief Engineer,  
Maharashtra State Electricity Distribution Co. Ltd.,  
Material Management Department,  
1<sup>st</sup> Floor, Prakashgad, Bandra (E),  
Mumbai – 400 056.

Dear Sir:

**Sub:** Undertaking against Tender No. \_\_\_\_ for procurement of \_\_\_\_\_

We, M/s. \_\_\_\_\_ having registered office at \_\_\_\_ are the Parent Company of M/s. \_\_\_\_\_ who have participated against your tender no. \_\_\_\_ for procurement of \_\_\_\_.

We have carefully read and have thoroughly understood and agree to the terms and conditions of the subject tender.

We hereby undertake that in case of placement of order against the subject tender on our subsidiary company, M/s. \_\_\_\_\_, in the event of we accept all the responsibilities and liabilities for supply of quality equipments as per specification of the tender and execution of the contract. We further hereby undertake that we shall be responsible for any liability arising out of the contract placed on M/s. \_\_\_\_\_ and to pay MSEDCL on demand the sum of rupees as per agreement in the event of any breach of condition of the purchase order, loss and damage of the material till expiry of guarantee period as stipulated in the order.

Our liability here under shall not be impaired or discharged by extension of time or variation or alteration made with or without our knowledge or consent by or between the parties to the said contract. This undertaking shall be valid and binding on us upto and including the execution and guarantee period of the order and shall not be terminable by notice or change in the constitution of any of the companies. In case of any dispute arising out of or in connection with this tender or contract, if concluded, the same shall be subject to the exclusive jurisdiction of the **“Court in Mumbai (India).”**

Yours faithfully,

(Authorised Signatory)

For \_\_\_\_\_

**FORMAT-2**

**Undertaking for not approached any one for undue influence.**

(To be submitted on letter head of the bidder)

Tender No. MMD/T-..... for supply of .....

**TO WHOM SO EVER IT MAY CONCEREN**

I / We \_\_\_\_\_ hereby submit the undertaking that our firm or our partners or directors have not approached any one for undue influence against the Tender/Bid.

If it is found that we have given wrong or misleading information then our offer shall be summarily rejected.

**Date:**

**Place:**

(Signature, Name of Authorized Representative  
& Company Seal)

**FORMAT-3**

**Format of Certificate from Chartered Accountant for not have controlling stake in more than one entity applied for the Tender/Bid.**

(To be submitted on Letter Head of the Chartered Accountant)

Tender No. MMD/T-..... for supply of .....

**TO WHOM SO EVER IT MAY CONCEREN**

I \_\_\_\_\_ hereby certify that the firm M/s \_\_\_\_\_ or its partners or directors does not have controlling stake in more than one entity applied for the Tender/Bid.

If it is found that they have given wrong or misleading information then their offer shall be summarily rejected.

**Date:**

**Place:**

(Seal, Signature & Name of C.A.with Regn. No. & UDIN No.)

**FORMAT-4**

Format of Certificate from Chartered Accountant for Average Annual Turnover  
(To be submitted on Letter Head of the Chartered Accountant)

Tender No. MMD/T-..... for supply of .....

TO WHOM SO EVER IT MAY CONCEREN

We have examined the audited financials of M/s \_\_\_\_\_, having its registered office at \_\_\_\_\_, for the financial years. Based on our examination, we hereby certify that Annual Turnover for respective financial year mentioned below is in accordance with the audited financial statements:

Financial Year	Assessment Year	Annual Turnover Amount In Rupees Lakhs.
	Total. Rs.	
	(Rs. ... ..Figure in words)	
	Average Annual Turnover Of Last Three Financial Years	

This certificate is given on the basis of copy of audited financial reports for profit/loss account and balance sheet.

Date:

Place:

(Seal, Signature & Name of C.A. with Regn. No. & UDIN No.)

**FORMAT-5**

Format for No Deviation Form

(To be submitted on letter head of the bidder)

Tender No. MMD/T-..... for supply of .....

**CERTIFICATE FOR NO DEVIATION**

We, (Bidder's Name), hereby certify that there is no technical or commercial deviation from the Conditions mentioned in Tender Document and I am agreeing to all the terms and conditions mentioned in the Tender Specification.

Bidders Name:

Authorized representative's signature:

Authorized representative's Name:

Seal of the company

Name and address of the Bidder

Date:

### Annexure 'B'(Price Schedule)

Sr.No	Item Code	Material Description	Unit	Quantity Required	HSN	Quantity Offered	Unit ExWorks including packaging charges but excluding duties & taxes etc (In Rupees )	Freight Charges Per Unit (In Rupees )	Transit Insurance Charge s Per Unit (In Rupees )	Integrated GST for outside State Transaction on (Ex-Works Price+Freight Charges + Transit Insurance Charges )(In Rupees)	Central GST for within State Transaction on (Ex-Works Price + Freight Charges + Transit Insurance Charges )(In Rupees)	State GST for within State Transaction on (Ex-Works Price + Freight Charges + Transit Insurance Charges)(In Rupees)	Free Door Delivery Price Per Unit by Road upto Destination/Stores/Sub Station (In Rupees)
1	2	3	4	5	6	7	8	9	10	11	12	13	14=(8+9+10+11+12+13)
1	85000804273	33 11KV, 10MVA POWER TRANSFORMER	NO	181	85042200								
2	85000803713	33 11 KV, 5 MVA POWER TRANSFORMER	NO	219	85042200								

## Delivery Details

[Delivery must in the units specified for the items as per Price Schedule]

First lot of \_\_\_\_ in assorted sizes will be delivered within 2 Months from the date of LOA Award. After this period supply will be completed at the rate of \_\_\_\_ in assorted sized per month

## Confirmation Details

We Confirm The Following :

I) Goods and Services Tax(GST) i.e Integrated GST / (Central GST+ State GST):

The GST is included in our prices quoted in price bid (Central GST+ State GST) for within Maharashtra State/Integrated GST for outside State and we shall not charge any additional amount towards Integrated GST / (Central GST+ State GST), during currency of contract except statutory variation by Central / State Government in normal (full) rate of Integrated GST / (Central GST+ State GST), in case of Integrated GST / (Central GST+ State GST) Rate is increased. In case the Integrated GST / (Central GST+ State GST) is decreased than the rate indicated in the price bid, the benefits of the reduction in the Integrated GST / (Central GST+ State GST) shall be passed on to the Purchaser. The increase in the Integrated GST / (Central GST+ State GST) rate due to increase in turnover during the contractual delivery period shall not be charged to the Purchaser. If the Integrated GST / (Central GST+ State GST) is not payable at present, we shall not charge the same, if it becomes applicable during the currency of contract due to expiry / withdrawal of tax concessions and incentives during the currency of contract except for statutory variation by Central / State Government.

(i) Necessary documentary evidence for the GST claimed by us shall be submitted along with the bills.

(ii) We here by declare that while quoting the price in the Price Bid, we have taken into account the entire credit on inputs available under the GST Act.



Technical Specification Item: 33 11 KV, 5 MVA POWER TRANSFORMER



Maharashtra State Electricity Distribution Company Limited

---

SPECIFICATION NO.MMC: MSC/DB/01 /2018

TECHNICAL SPECIFICATION

For

33 11 KV, 5 MVA POWER TRANSFORMER

For

DISTRIBUTION SYSTEM

IN

MSEDCL



**Technical Specification of 5 MVA and 10 MVA Power Transformer**



Maharashtra State Electricity Distribution Company Limited

---

**SPECIFICATION NO.**

**T & Q C : MSC-I / 5 & 10 MVA Power Transformer //2019 /08**

TECHNICAL SPECIFICATION

FOR

5 MVA & 10 MVA, 33/11 kV, 33/22 kV & 22/11 kV

POWER TRANSFORMERS

FOR

DISTRIBUTION SYSTEM

IN

MSEDCL



**Technical Specification of 5 MVA and 10 MVA Power Transformer**

**TECHNICAL SPECIFICATION NO.**

**T & Q C : MSC-I / 5MVA &10 MVA Power Transformer //2019 /03**

**I N D E X**

<b>Cl. No.</b>	<b>Contents</b>
1	Scope
2	System Particulars
3	Service Condition
4	Applicable Standards
5	Specific Technical Requirements for Mineral Oil Filled Power Transformer
6	General Technical Details
7	Minimum Protective devices on Power Transformer
8	Oil
9	Oil Preservation Equipment: Oil Sealing
10	Bushing Insulators and Terminals
11	Cable Box :
12	Marshalling Box Cubicle
13	Valves
14	Cable routing on Power Transformer
15	Radio Interference And Noise Level
16	Painting of transformer, Conservator, OLTC, Radiator, Marshalling box
17	Minimum Protective devices on Power Transformer
18	Nitrogen injection Fire Protection System (NIFPS)
19	Fittings and Accessories on Power Transformer
20	Tests
21	Rejection
22	Quality Assurance
23	Detail Progress Report
24	Drawing Approval
25	Stage Inspection
26	Final Inspection

**Technical Specification of 5 MVA and 10 MVA Power Transformer**

27	Challenge Testing
28	Guaranteed & Technical Particulars
29	Performance Guarantee
30	Cost Data Sheet
31	Schedules
32	Anx-I: Technical specification of Transformer oil
33	Anx-II: Technical specification of Nitrogen Injection Fire Protection System



**Technical Specification of 5 MVA and 10 MVA Power Transformer**

**MAHARASHTRA STATE ELECTRICITY DISTRIBUTION CO. LTD.**

**TECHNICAL SPECIFICATION FOR**

**5MVA & 10 MVA 33/11 kV, 33/22 kV & 22/11 kV**

**POWER TRANSFORMERS**

**SPEC. NO.T & Q C : MSC-I /5 MVA & 10 MVA Power Transformer //2019 /08**

**1 Scope:-**

- 1.1 This specification covers design, manufacturing, testing and delivery of Oil immersed, Oil Natural Air Natural (**ONAN**) Outdoor Type, Three Phase, 50 Hz, 5 MVA and 10 MVA 33/11 kV, 33/22 kV & 22/11 kV Step Down Power Transformers with On Load Tap Changer (**OLTC**) and Remote Tap Change Control (**R.T.C.C.**) panel, to be used in Sub Transmission/ Distribution system.
- 1.2 The equipment offered shall be complete with all parts necessary for their effective and trouble-free operation. Such parts will be deemed to be within the scope of the supply irrespective of whether they are specifically indicated in the commercial order or not.
- 1.3 It is not the intent to specify herein complete details of design and construction. The equipment offered shall conform to the relevant standards and be of high quality, sturdy, robust and of good design and workmanship complete in all respects and capable to perform continuous and satisfactory operations in the actual service conditions at site and shall have sufficiently long life in service as per statutory requirements. The dimensional drawings attached with this specification and the notes thereto are generally of illustrative nature. In actual practice, notwithstanding any anomalies, discrepancies, omissions, incompleteness, etc. in these specifications and attached drawings, the design and constructional aspects, including materials and dimensions, will be subject to good engineering practice in conformity with the required quality of the product, and to such tolerances, allowances and requirements for clearances etc. as are necessary by virtue of various stipulations in that respect in the relevant Indian Standards, IEC standards, I.E. Rules, I.E. Act and other statutory provisions.
- 1.4 The Tenderer/supplier shall bind himself to abide by these considerations to the entire satisfaction of the purchaser and will be required to adjust such details at no extra cost to the purchaser over and above the tendered rates and prices.
- 1.5 Tolerances:  
Tolerances on all the dimensions shall be in accordance with provisions made in the relevant Indian/IEC standards and in these specifications. Otherwise the same will be governed by good engineering practice in conformity with required quality of the product.



### Technical Specification of 5 MVA and 10 MVA Power Transformer

#### 2 System Particulars:-

- |      |   |   |  |       |      |
|------|---|---|--|-------|------|
| 2.1  | Nominal System Voltage  | : | 33 kV  | 22 kV | 11kV |
| 2.2  | Voltage variation on supply side  | : | ± 10 %   |       |      |
| 2.3  | Corresponding Highest System Voltage  | : | 36 kV  | 24 kV | 12kV |
| 2.4  | Frequency   | : | 50 Hz with ± 3 % tolerance   |       |      |
| 2.5  | Transient condition   | : | -20 % or + 10 % combined variation of voltage and frequency.   |       |      |
| 2.6  | Number of Phase   | : | 3  |       |      |
| 2.7  | Neutral earthing  | : | Solidly earthed.   |       |      |
| 2.8  | Short circuit withstand level   | : | 31.1 KA for 2 Sec for 22 kV and 33 kV<br>13.1 KV for 2 sec for 11 KV and 22kV  |       |      |
| 2.9  | Over voltage operating capability and duration                                  | : | 112.5 % of rated voltage(continuous)   |       |      |
| 2.10 | Noise level(As per IEC:551 and NEMA)  | : | 65db for 5 MVA and 69db for 10 MVA<br>(Noise level shall not exceed limits as per NEMA TR – 1.)                                    |       |      |
| 2.11 | Rated Lightning Impulse withstand Voltage kV Peak for 33/ 22 kV system.         | : | 170 kV   |       |      |
| 2.12 | Rated Lightning Impulse withstand Voltage, kV Peak for 11 kV system.            | : | 75 kV  |       |      |
| 2.13 | Rated short duration Power frequency Withstand voltage, kV rms 33/ 22 kV system | : | 70 kV  |       |      |
| 2.14 | Power frequency withstand voltage kV rms 11 kV system                           | : | 28 kV  |       |      |
| 2.15 | System fault level for 33 / 22 kV   | : | 1500 MVA   |       |      |
| 2.16 | System fault level for 11 kV  | : | 500 MVA  |       |      |
| 2.17 | Harmonic current  | : | Designed for suppression of 3 <sup>rd</sup> , 5 <sup>th</sup> , 7 <sup>th</sup> Harmonic voltages and high frequency disturbances. |       |      |



### Technical Specification of 5 MVA and 10 MVA Power Transformer

#### 3. Service Conditions:

A) The 5 MVA and 10 MVA Power Transformers to be supplied against this specification shall be suitable for satisfactory continuous operation under the following tropical conditions.

3.1	Maximum ambient temperature (Degree C)	50
3.2	Maximum temperature in shade	45
3.3	Minimum Temperature (Degree C)	3.5
3.4	Relative Humidity (percent)	100 %
3.5	Maximum Annual rain fall (mm)	1450
3.6	Maximum wind pressure (kg/sq.m)	150
3.7	Maximum altitude above mean sea level ( Meter)	1000
3.8	Isoceranic level (days per year)	70
3.9	Seismic level (Horizontal Acceleration)	0.3 g
3.10	Climatic Condition	Moderately hot and humid tropical climate conducive to rust and fungus growth.

B) The climatic conditions are prone to wide variations in ambient conditions and hence the equipment shall be of suitable design to work satisfactorily under these conditions.

#### 4. Applicable Standards:

- 4.1 Unless otherwise modified in this specification the transformers shall comply with the Indian Standard Specification IS: 2026 latest or relevant International Standard such as ANSI, OSA, DIN, IEC etc., acceptable to the purchaser. The specified equipments are of standard industrial type and can be supplied by manufacturers active in the international market.
- 4.2 Equipment meeting with the requirements of other authentic standards, which ensure equal or better quality than the standards mentioned above, shall also be considered. Two copies of such standards, in authentic English translation shall be furnished along with the offer.
- 4.3 Equipment offered shall comply with all currently applicable statutory requirements, regulations and safety codes applicable for design, quality of material and construction manufacture, inspection and performance.
- 4.4 In case of conflict arising out due to variations between the applicable standard and The standards specified herein the provisions of this specification shall prevail.



### Technical Specification of 5 MVA and 10 MVA Power Transformer

Sr. No.	Applicable Standards	Details
1.	IS : 2026	Power Transformer
2.	IEC : 60076	
3.	IEC : 60354	Loading guide for oil immersed Power Transformer. IS: 2026-7
4.	IS : 2026-7, IS : 6600	
5.	IEC : 60551	Determination of sound levels of Transformer and reactors.
6.	IEC : 60214	On load tap changer.
7.	IS : 8468	
8.	IEC : 60156	Method for determination of the electric strength for insulating oils.
9.	IEC : 60296	Specification for unused Mineral insulating oils for Transformer and switchgear.
10	IS : 335:2018 (vth Revision )	New Insulating oil.
15.	IEC : 60606	Application guide for Power Transformer.
16	IS : 3639	Fitting and accessories for Power Transformer
17	IS : 10028	Code of practice for selection, installation and maintenance of transformer.
18.	IEC : 60616	Terminal and tapping marking for Power Transformer.
19.	IEC : 60445	Basic and safety principle for man-machine interface, marking and identification of equipment terminal and conductor termination.
20,	IS :5561	Electrical power connectors.
21.	IS :1271	Thermal evaluation and classification of electrical insulation
22.	IEC : 60071	Co-ordination of insulation.
23.	IEC : 60034	Rotating electrical machines.
24.	IEC : 60947	Low voltage switchgear and control gear.
25.	IS : 13947	LV switchgear and control gear- Part : 1.
26.	IS :325	Three phase induction motors.
27.	IS :6272	Industrial cooling fans.
28.	BS : 2562	Cable boxes for transformers and reactors. As per CBIP-317-2013)
29.	IEC : 60137	Bushing for alternating voltages above 1000V.
30.	BS : 223	
31.	IS :2099	
32.	IS :3347	Dimensions for Porcelain Transformer bushing.





### Technical Specification of 5 MVA and 10 MVA Power Transformer

33.	IEC : 60529	Degrees of protection for enclosures.( IP).
34.	IS :3347	Gas operated relays.
35.	IS : 5	Colors for ready mix.
36.	IS : 3034	High velocity water spray system.
37.	IS : 1239	Heavy seamless Carbon steel pipe.
38.	IS : 14846	Sluice / Gate valve.
39.	National Fire Protection Association (National Fire code 1993) NFPA, USA.	
40.	Loss Prevention Association.(LPA)	
41.	Indian Electricity Rules.	
42.	Indian Electricity Act.	
49.	CBIP Manual.-295	

If the standard is not quoted for any item, it shall be presumed that the latest version of Indian Standard shall be applicable to that item.

Equipment meeting with the requirements of other International standards which ensure equal or better performance than the standards mentioned above shall also be considered. When the equipment offered by the supplier conforms to other standards, salient points of difference between standards adopted and the standards specified in this specification shall be clearly brought out in the offer. Two copies of such standards with authentic translation in English shall be furnished along with the offer.

#### 5.0 Specific Technical Requirements for Mineral Oil filled Power Transformer:

5.1 **Standard MVA Ratings:-** 5 MVA and 10 MVA (Continuous capacity).

5.2 **Rated Voltage :**

i. Primary Voltage - 33 kV or 22 kV

ii. Secondary voltage - 22 kV or 11 kV

5.3 **Temperature Rise:**

i. The temperature rise for top oil over an ambient temperature of 50 °C should be 50 °C maximum (measured by thermometer in accordance with IS 2026 or relevant International Standard).

ii. Temperature rise for winding over an ambient temperature of 50 °C should be 55 °C maximum (measured by resistance in accordance with IS 2026 or relevant International Standard).

5.4 **System Earthing:**

Neutral of LV side to be solidly earthed

5.5 **No Load voltage ratio:-**

The No Load Voltage ratio corresponding to the principal tapping shall be 33,000/11,000 Volts, 33000/22000 Volts or 22,000/11,000 Volts.



### Technical Specification of 5 MVA and 10 MVA Power Transformer

#### 5.6 Flux density:-

Flux density should not be more than **1.69** Tesla Transformer core should be designed in such a way that it will not get saturated for any value of V/f (Voltage/frequency) ratio to the extent of 112.5% of rated value of V/f ratio (i.e. 11000/50, 22000/50, 33000/50). Actual core design along with calculations in support of it should be enclosed with the offer.

#### 5.7 Current Density:

The current density for HV & LV windings should not exceed 2.8 A / mm<sup>2</sup> for electrolytic copper conductor at any working tap including extreme tap 17 (-15% voltage).

#### 5.8 Magnetizing Current:-

- The magnetizing current at normal voltage & frequency shall be limited to 1% of full load current.
- The magnetizing current at maximum voltage & frequency shall be limited to 3% of full load current.

#### 5.9 Impedance Values :

Percentage impedance voltage on normal taps & rated MVA at 75° C.

Base MVA	% impedance	IS Tolerance
5	7.15 %	± 10%
10	8.35 %	± 10%

#### 5.10 Minimum clearances:

Following minimum clearances in air and oil shall be maintained:

Voltage	Phase to phase (in mm)	Phase to Earth out of Oil (in mm)	Phase to Earth in Oil (in mm)
11 KV	280	140	25
22 KV	400	320	40
33 KV	400	320	40

#### 5.11 Losses:

The losses shall not exceed the value given below

Voltage Ratio	No load Losses(fixed) (KW)	Load Losses (kW at 75 ° C)	No load Losses (fixed) (KW)	Load Losses (kW at 75 ° C)
	<b>5 MVA</b>		<b>10MVA</b>	
33/11	4	23	7	50
33/22	4	23	7	50
22/11	4	23	7	50



### Technical Specification of 5 MVA and 10 MVA Power Transformer

**5.12 Vector Group :** Dyn 11

**5.13 Anticipated unbalanced loading :**  $\pm 10\%$

**5.14 Anticipated continuous loading of winding (HV/LV) :** 110 % of rated current

## **6.0 General Technical Details:**

### **6.1 Core :-**

- a) Material to be used for the transformer core shall be made of premium grade Imported Cold Rolled Grain Oriented (CRGO) M4 or better with high grade, non-ageing, low loss and high permeability cold rolled grain oriented silicon steel laminations. Only those bidders who directly imported CRGO either from the manufacturer or through their accredited marketing organization of reputed (and not through any agent) shall be considered. In support of this requirement the bidder shall submit an undertaking in specified format (schedule C) in the form.
- b) The CRGO shall be cut at Mill's authorized Processing unit only.
- c) Lamination thickness should be maximum 0.27 mm with insulation coating on both sides.
- d) Flux density should not exceed **1.69** Tesla at rated voltage and frequency. Flux density should not exceed **1.9** Tesla at 112.5 % of rated voltage and frequency
- e) The design of the magnetic circuit shall be such as to avoid static discharges, development of short circuit paths within itself or to the earthed clamping structure and production of flux component at right angles to the plane of laminations which may cause local heating.
- f) The Core design shall be compact with least possible air gap and rigid clamping for minimum core loss and noise generation.
- g) Core shall be adequately braced to withstand bolted faults on secondary terminals without mechanical damage and displacement during transportation and positioning.
- h) All steel sections used for supporting the core shall be thoroughly sand blasted after cutting, drilling and welding
- i) Each core lamination shall be insulated with a material that will not deteriorate due to pressure and hot oil
- j) The supporting frame work of core shall be so designed as to avoid presence of pockets which would prevent complete emptying of the tank through drain valve or cause trapping of air during oil filling.
- k) The bidder shall provide saturation curve of the core material proposed to be used and calculations.
- l) Adequate lifting lugs shall be provided to lifting the core coil assembly.
- m) The framework and clamping arrangements shall be earthed.
- n) Insulation of Core to bolt and core to clamps shall be able to withstand a voltage.
- o) The core shall be bolted to the bottom plate of the tank secularly.
- p) Suitable magnetic shunts may be provided at the tank wall.



### Technical Specification of 5 MVA and 10 MVA Power Transformer

The successful bidder, shall be required to submit the manufacturer's test report showing the Watt Loss per kg and the thickness of the core lamination, to ascertain the quality of Core materials.

The purchaser reserves the right to get sample of the core material tested at any Government recognized laboratory.

#### 6.2 Windings:

- a) The supplier shall ensure that windings of the transformers are made in dust proof environment. The conductors shall be of Electrolytic Grade copper as per relevant standard.
- b) The Class „A“ insulation of transformer windings and connections shall be free from compounds which are liable to ooze out, shrink or collapse and shall be non catalytic in transformer oil during service. The winding insulation shall be uniform.
- c) Coil assembly and insulating spacers shall be so arranged as to ensure free circulation of oil and to reduce the hot spot of the winding.
- d) The conductors shall be transposed at suitable intervals in order to minimize eddy current and to equalize the distribution of current and temperature along the windings.
- e) The windings shall be so designed that all coil assembly of identical voltage rating shall be interchangeable
- f) Insulation of HV and LV winding shall be adequate to withstand surge voltages appearing across them as a result of transfer due to an impulse striking on HV and LV terminals.
- g) Adequate shrinkage to stack of coil should be carried out before final assembly.
- h) Connection shall be braced to withstand shock during transport, switching, short circuit or other transients.
- i) At all voltage ratios there shall be minimum out of forces in the transformer winding.
- j) Threaded connection with locking facility and transported at sufficient intervals.
- k) Provision of taps as per requirement.
- l) Core coil assembly shall be mounted on bottom of tank. Earthing of core clamping Structure and Earthing of magnetic circuit shall be in line with CBIP manual.

#### 6.3 Tank:

- a) The transformer tank and cover shall be fabricated from good, commercial grade, low carbon robust mild steel plate of tested quality, **The thickness should be min 6 mm for side wall and 8mm for top and bottom cover for 5 MVA transformer and 8 mm for side wall and 10mm for top and bottom cover for 10 MVA Power Transformer ,suitable for welding.** The thickness should be adequate for meeting the requirement of pressure and vacuum type tests as per CBIP. Test will be conducted on each transformer tank for design validation.
- b) The tank shall be of welded construction. All seams and those joints not required to be opened at site shall be double welded. All welding shall be stress relieved for sheet greater than 35mm. All pipes, stiffeners etc, shall be welded



### Technical Specification of 5 MVA and 10 MVA Power Transformer

externally. The tank stiffeners shall be adequately sloped to prevent accumulation of water. The tank shall have sufficient strength to withstand without permanent distortion under following conditions:

- i. Oil filling under vacuum.
  - ii. Continuous internal gas pressure of **35 kN/m<sup>2</sup>** with oil at operating level and
  - iii. Normal Mechanical shock during transportation, jacking, loading and unloading operations.
- c) There shall be adequate space for collection of sediments at the bottom of tank. Tank bottom with welded skid base.
  - d) There shall not be any internal pockets in which gas / air can accumulate and external pocket in which water can lodge.
  - e) The tank cover shall be bolted to the tank and minimum disconnection of pipe work and accessories for cover lifting.
  - f) The tank of the transformer shall be complete with all accessories and shall be designed so as to allow the complete transformer filled with oil to be lifted by crane or jack transported by road, rail or water way without over straining any joints and without causing subsequent leakage of oil.
  - g) The main tank body excluding tap changing compartments and radiators shall be capable of withstanding a vacuum of **68 kN/m<sup>2</sup>** (500 mm of Hg.).
  - h) The base of each tank shall be so designed that it shall be possible to move the complete transformer unit by skidding on plates or rails in any direction without injury.
  - i) Suitable guides shall be provided in the tank for positioning the core and coil assembly.
  - j) All Control cabinets and marshaling kiosks being supplied as transformer accessories, except OLTC. Remote control panel shall be preferably mounted on the transformer body. No cabinet or marshaling kiosk shall be mounted on radiators.
  - k) Top of the tank cover shall be sloped towards HV side by approximately upto 10° to prevent retention of rainwater.
  - l) The thermometer pockets shall be fitted with captive screwed top to prevent the ingress of water.
  - m) The thermometer pockets shall be located in the position of maximum oil temperature at continuous and it shall be possible to remove the instrument bulbs without lowering the oil in the tank.
  - n) Inspection covers (Manhole) shall be rectangular in shape and flanged adequately. The tank cover and the inspection covers (Manhole) shall be provided with suitable lifting arrangements. Inspection covers (Manhole) shall not weigh more than 25 Kg each. Sufficient size of Inspection covers (Manhole) shall be provided for inspection of core and winding. Overall design shall be in such a way that there shall not be any hindrance / overlapping of some other component in front of the Inspection covers ( Manhole).
  - o) Tank to be design for oil filling under vacuum.
  - p) Core, frame and tank earthing links shall be provided on tank top with the help of epoxy housing and shorted with links in normal operating condition.



### Technical Specification of 5 MVA and 10 MVA Power Transformer

#### 6.4 Main Conservator tank:-

- a) Conservator should be volumetric capacity of at least 10 % of total volume of oil in the tank. Moreover the oil in conservator up to the minimum level mark on the oil level gauge should be at least 3 % of the total volume of oil in the transformer excluding oil in the OLTC. Conservator having a capacity between the highest and the lowest visible levels to meet the requirement of expansion of the total cold oil volume in the transformer and cooling equipment from the minimum ambient temperature i.e.  $-5^{\circ}\text{C}$  to  $98^{\circ}\text{C}$ .
- b) Flexible rubber bag (Air cell) should be provided inside of conservator tank for oil preservation system. Air cell material shall be special type of fabric coated with special grade nitrile rubber whose outer surface is oil resistant and inner surface is ozone resistant. It shall be possible to remove or replace the Air cell if required.
- c) Conservator shall be bolted into position so that it can be removed for easy cleaning and other maintenance work. Main pipe from tank shall be projected about 20 mm above conservator bottom for creating a sump for collection of impurities. Minimum oil level in conservator corresponding to minimum temperature shall be well above the sump level.
- d) Conservator shall be supported at minimum two points to Main tank.
- e) Conservator shall be mounted in such a way that the top cover of the transformer can be lifted without disturbing the conservator.
- f) Following fittings and accessories shall be provided on Main tank conservator:
  - i) Prismatic oil gauge with three position Normal, Minimum and Maximum marking.
  - ii) End cover.
  - iii) Oil feeling hole with cap.
  - iv) Magnetic Oil gauge with LOW LEVEL alarm.
  - v) Silica Gel Dehydrating Breather with oil seal and filter . Container and oil cup should be polycarbonate single piece clearly transparent cover and resistant to UV rays.
  - vi) Drain cum filling valve (Gate valve with locking rod and position indicator, made of Brass 25 mm with cover plate.
  - vii) Shut off valve (Gate valve) with position indicator made of Brass 80 mm located before and after Buccholz relay.
  - viii) Flange for Breather connection.
  - ix) Air release valve on conservator made of Brass 25 mm with cover plate.
- g) Breather body should be Aluminum pressure die cast, shot blasted and powder coated. Container and oil cup should be 143R grade UV resistant polycarbonate. All gaskets should be of nitrile cork (RC 70C) rubber. Breather should be flanged type . Breather piping shall not any valve placed in between conservator and breather. Breather shall be removable type mounted at suitable height from ground level. Breather shall be tested for 0.35 kg / cm for all joints. Silica Gel used in breather should be 2.5 mm diameter ROUND BALL type and should be bio-degradable, non- carcinogenic.



## Technical Specification of 5 MVA and 10 MVA Power Transformer

### 6.5 Radiator Arrangement:

- A) Radiators shall be so designed as to avoid pockets in which moisture may collect and shall withstand the pressure tests B. Unless the pipe work is shielded by adequate earthed metal the clearance between all pipe work and live parts shall be more than the clearance for live parts to earth. Material for radiators shall be pressed steel or Stainless steel and thickness of material shall be 1.25 mm minimum.
- i. Each radiator block shall have shut off valves, lifting lugs, top and bottom oil filling valves, air release plug, a drain valve (25 mm) and fitted with captive screw cap on the inlet and outlet.
  - ii. Each radiator shall be provided with:
    - a) One shut off valve at the top (80 mm size)
    - b) One shut-off valve at the bottom (80 mm size)
    - c) Air release device at the top
    - d) Drain plug at bottom
    - e) Lifting lugs.
    - f) Expansion bellows to be provided in pipes between main tank and radiator headers. Top plate of tank cover shall be easily removable at site hence radiator header pipe shall not originate from top cover of transformer.
    - g) Radiator support from ground if required.

#### B) Radiator accessories:

2 No's of radiators with top and bottom shut-off-valves, air release plug and drain plug, Air release device. The no. of radiators/fins and heat dissipation calculation to justify the no. of radiators shall be submitted along with the offer.

### 6.6 On Load Tap Changer:

#### 6.6.1) General Requirement:

External to tank. Each transformer shall be provided with voltage control equipment of the tap changing type for varying its effective transformation ratio whilst the transformers are on load.

- a) **Type:** External to tank type OLTC, Mineral oil
- b) **OLTC Location:** External to tank type OLTC- Side mounted on conservator side not in front of HV bushing and OLTC gear shall be covered with protective gear shaft around it.
- c) **Operation of OLTC gear :** The tapping shall be controlled by a high speed resistor transition type gear in which tap change is carried out virtually under „No volt“ “ No ampere” condition. The selector switches do not make and break any current, main current is never interrupted and a resistor is provided to limit the arcing at diverted contacts to minimum suitable for outdoor mounting and continuously rated for operating at all positions including position in the middle of tap change. Selection of Local / Remote operation of OLTC gear is by selector switch on OLTC drive mechanism.





### Technical Specification of 5 MVA and 10 MVA Power Transformer

Local operation from OLTC drives mechanism through pistol grip rotary switch as well as emergency mechanical hand operation.

Remote operation from Digital RTCC provided by MSEDCL or SCADA depending on the selection of control on Digital RTCC panel.

**Safety interlocks:** Following minimum safety interlocks to be provided in OLTC:

- 1) Positive completion of tap changing step once initiated.
  - 2) Blocking of reverse tap change command during a forward tap change already in progress until the mechanism resets and vice-versa.
  - 3) Cutting of electrical circuits during mechanical operation.
  - 4) Mechanical stop to prevent overrunning of the mechanism at the end taps.
  - 5) Raise / Lower command in OLTC and Digital RTCC shall be positively interlocked.
- d)** OLTC gear shall be motor operated suitable for local as well as remote operation. An external hand wheel/ handle shall be provided for local manual operation. This hand wheel/ handle shall be easily operable by a man standing at ground level.
- e)** Arrangement shall be made for securing and padlocking the tap changer wheel in any of the working positions and it shall not be possible for setting or padlocking the wheel in any intermediate position. The arrangement shall be such that no padlock key can be inserted unless all contacts are correctly engaged and switch set in a position where no open or short circuit is possible. An indicating device shall be provided to show the tap in use.
- f)** The details of the method of diversion of the load current during tap changing, the mechanical construction of the gear and the control features for OLTC gear along with detailed drawings on the inner view and the arrangement of connections, shall be submitted with the bid. Information regarding the service experience on the gear and a list of important users shall be furnished. The tap changer shall change the effective transformation ratio without producing phase displacement.
- g)** The current diverting contacts shall be housed in a separate oil chamber not communicating with the oil in main tank of the transformer.
- h) Tapings :** The transformers with on load taps shall have taps ranging from +5% to -15% in 16 equal steps of 1.25% each on HV winding (17 position) for HV variation for constant voltage on LV side. The transformer shall be capable of being operated without danger on any tapping at the rated 5 or 10 MVA with voltage variation of  $\pm 10\%$  corresponding to the voltage of that tapping. 9<sup>th</sup> tap, + 3.6 to -7.2 @ 1.2+5.4 to -10.8 @1.8.
- i) OLTC features :**  
 OLTC mechanism and associated controls shall be housed in an outdoor with IP 55, weatherproof, vermin proof and dust proof cabinet.  
 It shall be ensured that oil in compartments containing contacts making and breaking current and Main transformer tank should not mix.  
 The hand cranking arrangement shall be such that it can be operated at standing height from ground level.





**Technical Specification of 5 MVA and 10 MVA Power Transformer**

- j) Bill of Material for OLTC mechanism :** Drive Mechanism shall be of MA 9 with stainless steel enclosure.
- 1) Control circuit transformer 433/55,0-55 V, adequate capacity.
  - 2) Local / Remote selector switch 1 phase, 2 way, 6 Amp, Pistol grip.
  - 3) Retaining switch Raise / Lower.
  - 4) Handle interlock switch.
  - 5) Raise / Lower switch 1 phase, 2 way, 6 Amp, Pistol grip.
  - 6) Lower limit switch.
  - 7) Raise limit switch.
  - 8) Tap Changer Motor 433 V AC, 3 phase, adequate rating.
  - 9) Motor protection relay with single phasing preventer.
  - 10) Motor control contactors Raise / Lower.
  - 11) Stepping relay.
  - 12) Out of step switch.
  - 13) Tap position indicator.
  - 14) Operation counter.
  - 15) Emergency stop Push Button.
  - 16) Pressure relief valve and Oil surge relay should be provided to OLTC.
  - 17) Drive Mechanism box shall be either Stainless steel 314 or better or Aluminum pressure diecasted only.
  - 18) OLTC timer scheme to trip MPCB for continuous tap operation.
  - 19) Potential free contacts for OLTC supply Healthy, OLTC control supply Healthy, Tap change in progress and OLTC timer trip.
  - 20) All disconnecting type terminals shall be of POLYAMIDE stud type and screwdriver operated minimum 8 mm width.
  - 21) Drive Mechanism accessories :
    - a) Cubicle lamp with door switch and separate fuse / MCB with external ON / OFF switch on front of cover of OLTC drive mechanism.
    - b) Approved space heaters controlled by thermostat and separate fuse / MCB.
    - c) Incoming Fuse / MCB for incoming supply.
    - d) Panel wiring diagram fixed on back of panel door Aluminum engraved plate fixed with rivet.
    - e) Nylon 66 Terminal block minimum 4 sq. mm screw type with 10 % spare terminals.
    - f) Stainless steel door handle with lock and additional facility for padlock.
    - g) Earthing boss.
  - k)** Separate conservator should be there for OLTC. Main tank conservator should not be used for OLTC.
  - l)** The contacts shall be accessible for inspection without lowering oil level in the main tank and the contact tips shall be replaceable.
  - m)** The Contractor shall indicate the safeguards in order to avoid harmful arcing at the current diverting contacts in the event of operation of the OLTC gear under over-load



### Technical Specification of 5 MVA and 10 MVA Power Transformer

conditions of the transformer. Necessary tools and tackles shall be provided along with main supply for maintenance of OLTC gear.

- n) The OLTC oil chamber shall have oil filling and drain plug, oil sampling valve, relief vent and level glass. It shall also be fitted with an oil surge relay the outlet to which shall be connected to separate conservator tank.
- o) The diverter switch or arcing switch shall be so designed as to ensure that its operation once commenced shall be completed independently of the control relays or switches, failure of auxiliary supplies etc. To meet any contingency which may result in incomplete operation of the diverter switch, adequate means shall be provided to safeguard the transformer and its ancillary equipment.
- p) Drive mechanism chamber shall be mounted on the tank in accessible position. It should be adequately ventilated and provided with anti condensation metal clad heaters. All contractors, relay coils and other parts shall be protected against corrosion, deterioration due to condensation, fungi etc.
- q) The control feature shall provide the following Equipment for local and remote electrical and local manual operation shall be provided and shall comply with the following conditions:
  - 1) Local-remote selector switch mounted in the local control cubicle (tap change driving unit) shall switch control of OLTC for lower/raise functions in local or remote mode as selected.
  - 2) The LOCAL-REMOTE selector switch shall have at least two spare contacts per position which are closed in that position but open in the other position.
  - 3) A RAISE-LOWER CONTROL SWITCH shall be provided in the Local Control Cubicle. The switch shall be spring loaded to return to the Centre „OFF“ position and shall require movement to the RIGHT to raise the voltage of the transformer. Movement to the left shall lower the voltage. Alternatively push button type arrangement of standard design may be provided. This switch shall be operative only when „local remote“, selector switch is in „local“ position.
  - 4) An OFF-ON tap changer control switch shall be provided in the OLTC local control cabinet for transformer. The tap changer shall be inoperative in the OFF position. Also the OFF-ON switch shall have at least one spare contact per position which is closed in that position but open in the other position.
  - 5) Operating mechanism for on load tap changer shall be designed to go through one step or tap change per command. Subsequent tap changes shall be initiated only by a new or repeat command.
  - 6) On load tap changer shall be equipped with a time delay in-complete STEP alarm consisting of a normally open contact which closes, if the tap changer fails to make a complete tap change. The alarm shall not operate for momentary loss of auxiliary power.
  - 7) The sensing units or approved equivalents shall be installed in the local OLTC control cabinet to provide tap position indication for the transformer. Complete mounting details shall be included with approved diagram.
  - 8) Transformer load tap changer shall be equipped with a fixed resistor network capable of providing discrete voltage steps for input to the supervisory system.



### Technical Specification of 5 MVA and 10 MVA Power Transformer

- 9) Limit switches shall be provided to prevent overrunning of the mechanism and in addition, a technical stop shall be provided to prevent over-running of the mechanism under any condition.
- 10) Limit switches may be connected in the control circuit of the operating motor provided that a mechanical-de-clutching mechanism is incorporated.
- 11) Thermal device or other means shall be provided to protect the motor and control circuit. All relays switches, fuses etc. shall be mounted in the drive mechanism chamber and shall be clearly marked for the purpose of identification. They shall withstand the vibrations associated with tap changer gear operation.
- 12) A permanently legible lubrication chart shall be fitted within the driving mechanism chamber.
- 13) Any „DROP DOWN“ tank associated with the tap changing apparatus shall be fitted with guide rod to control the movements during lifting or lowering.
- 14) The guide rods shall be so designed as to take support of the associated tank when in the fully lowered position with oil. Lifting gear fitted to „DROP DOWN“ tanks shall include suitable device to prevent run- away during lifting and lowering operations. They shall be provided with adequate breathing arrangement.
- 15) If specified the tap changer shall be mounted in such a way that the cover of the transformer can be lifted without removing connections between windings and tap changer.
- 16) A five digit counter shall be fitted to the tap changing equipment to indicate the number of operations completed. Suitable apparatus shall be provided for each transformer to give indications as follows. To give an indication at the remote control point that a tap change is in progress by means of an illuminated lamp.
- 17) All relays and operating devices shall operate correctly at any voltage between the limits specified.
- 18) It shall not be possible to operate the electric drive when the manual operating gear is in use. It shall not be possible for any two controls to be in operation at the same time.
- 19) The equipment shall be suitable for supervisory control and indication with make before break multi-way switch, having one potential free contact for each tap position. This switch shall be provided in addition to any other switch/switches which may be required for remote tap position
- 20) Operation from the local or remote control switch shall cause one tap movement only until the control switch is returned to the off position between successive operations.
- 21) All electrical control switches and the local operating gear shall be clearly labeled in a suitable manner to indicate the direction of tap changing.
- 22) Transfer of source failure of one AC supply shall not affect tap changing operation.
- 23) The equipment shall be so arranged as to ensure that when a tap change has been commenced it shall be completed independently of the operation of the



### **Technical Specification of 5 MVA and 10 MVA Power Transformer**

control relays or switches. If a failure of the auxiliary supply during a tap change or any other contingency such as tap changer getting stuck would result in that movement not being completed, adequate means shall be provided to safeguard the transformer and its auxiliary equipment. The tap changing switches and mechanism shall be mounted in oil tanks or compartments mounted in an accessible position on the transformer tank.

Any enclosed compartment not oil filled shall be adequately ventilated, metal clad thermostatically controlled heaters shall be provided in the driving mechanism chamber and in the marshalling box, all contactors, relay coils or other parts shall be suitably protected against corrosion or deterioration due to condensation, fungi, etc.

The tap changer contacts which are not used for making or breaking current like separate selector switch contacts can be located inside main transformer tank where tap changer construction permits such an arrangement. On load tap changers having separate compartment for selector contacts, the oil in such compartment shall be maintained under conservator had by means of pipe connection from the highest point of the chamber to the conservator. Such connection shall be controlled by suitable valve and shall be arranged so that any gas leaving the chamber will pass into the gas and oil actuated relay. A separate surge relay may be provided for this compartment.

It shall not be possible for the oil in these compartments of the tap change equipment, which contain contacts used for making or breaking current, to mix with the oil in the compartments containing contacts not used for making or braking current

#### **6.6.2 Manual Control :**

The cranking device for manual operation of the OLTC gear shall be removable and suitable for operation by a man standing on ground level.

**The mechanism shall be complete with the following:**

- 1) Mechanical tap position indicator which shall be clearly visible to the person operating tap changer manually at the transformer.
- 2) A mechanical operation counter.
- 3) Mechanical stops to prevent over-cranking of the mechanism beyond the extreme tap positions.
- 4) The manual control considered as back up to the motor operated load tap changer control shall be interlocked with the motor to block motor start-up during manual operation. The manual operating mechanism shall be labeled to show the direction of operation for raising the voltage and vice versa.

#### **6.6.3 Electrical Control :**

This includes the following:

- 1) Local Electrical control
- 2) Electrical remote control from remote control panel.

The control circuits shall have the following features:



### Technical Specification of 5 MVA and 10 MVA Power Transformer

- a) An interlock to cut off electrical control automatically upon recourse being taken to the manual control in emergency
- b) Reinforcement of the initiating impulse for a tap change, ensuring a positive completion once initiated to the next (higher or lower) tap.
- c) Step-by-step Operation ensuring only one tap change from each tap changing impulse and a lock-out of the mechanism if the control switch (or push button) remains in the "operate" position
- d) An interlock to cut-out electrical control when it tends to operate the gear beyond either of the extreme tap positions.
- e) An electrical interlock to cut-off a counter impulse for reverse step change being initiated during a progressing tap change and until the mechanism comes to rest and resets circuits for a fresh position.
- f) Tap change in progress by means of an indicating lamp at the remote panel. Necessary contacts for this and for remote tap position indicator at remote panel shall be provided by the Contractor.
- g) Protection apparatus, considered essential by the Contractor according to specialties.
- h) Remote Electrical Group Control.

The OLTC control scheme offered shall have provision of remote electrical group Control during parallel operation of transformers. This is in addition to independent control of OLTC.

- i) A four position selector switch having MASTER, Follower, Independent and OFF position shall be provided in the remote OLTC control panel for each transformer. This shall be wired to enable operator to select operation of OLTC in Master, Follower or Independent mode.
- ii) Out of step relays with timer contacts shall also be provided to give alarm and indication in case of tap positions in all the transformers under group control being not in same position. An out-of-step device shall be provided for each transformer which shall be arranged to prevent further tap changing when transformers in a group operating in „Parallel control“ are one tap out-of-step.
- iii) Master Position: -  
If the selector switch is in MASTER position, it shall be possible to control the OLTC units in the FOLLOWER mode by operating the controls of the MASTER unit Independent operation of the units under FOLLOWER mode shall have to be prevented. However, the units under independent mode will be controlled independently
- iv) Follower Position:  
If the selector switch is in FOLLOWER mode, control of OLTC shall be possible only from MASTER panel
- v) Independent Position: In this position of Selector Switch, Control of OLTC of individual unit only shall be possible.
- vi) An out of step device shall be provided for each transformer which shall be arranged prevent further tap changing when transformers in a group operating in parallel control are one tap out of step.



### Technical Specification of 5 MVA and 10 MVA Power Transformer

#### 6.6.4 Tapping method :

- a) The switch position no.1 shall correspond to the maximum plus tap.
- b) The primary winding shall be connected delta and secondary winding star as per vector group Dyn 11 (IS 2026 latest version.) so as to produce a positive displacement of 30 deg. From the primary to the secondary vector of the same phase (vector rotation assumed counter clockwise).
- c) The neutral point of the secondary winding shall be solidly earthed and should be brought out to separate insulated terminal through an earthing current transformer for an earth leakage relay to be connected whenever required.

#### 6.6.5 Local OLTC Control Cabinet :

The auxiliary devices for electrical control of the OLTC shall be housed in a weather proof cabinet. It shall be complete with the following:

- a) A circuit breaker / contactor with thermal overload devices for controlling the AC auxiliary supply to the OLTC motor.
- b) Cubicle light with door switch.
- c) Space heaters to prevent condensation of moisture
- d) Padlocking arrangement for hinged door of cabinet.
- e) Cable terminal glands for power and control cables to the OLTC gear.

#### 6.6.6 Remote Tap Changer Control (RTCC) Panel :

- A) The auxiliary devices for remote electrical control of the OLTC and Cooler shall be housed in a separate panel to be placed in the Control room. The panel shall be made of sheet steel of thickness not less than **14 SWG** and it shall be duly finished with Stoved Enamel paint. The size and color of the control cubicle to be supplied by the supplier shall be **750 mm** depth and **2312 mm** height and Olive Green (shade no.220, IS : 5 ) respectively. The width of the cubicle may be as per the suppliers practice. The cabinet sealing system shall have a degree of protection not less than IP-42.

The Control and signal devices required to be mounted in the RTCC Panel shall comprise of the following :

- a) Relays in the control circuit for the operation of the transformers in parallel.
- b) Remote Tap position indicator.
- c) (i) Tap changer in progress.  
(ii) Tap changer out of step.
- d) Lamps (white) showing healthy auxiliary supply from 240/110 Volts Center point earthing transformer.
- e) Time delay contactors 1-5 Seconds with 5 Amps. Contacts for tripping when a follower fails to go into steps with the master together with indication.
- f) Oil temperature alarm with suitable cancellation device.
- g) Winding Temperature alarm with suitable cancellation device for 5 MVA & 10 MVA Transformer.
- h) Signaling apparatus for out-of-step alarm.
- i) Time delay contactors 1-5 Seconds for tripping due to incorrect coupling in.





### Technical Specification of 5 MVA and 10 MVA Power Transformer

- j) Master position (out of step tripping). The desired time delay for tripping will be to 50 Seconds.
  - k) Remote Push Button for Lower & Raise Tap.
  - l) Alarm cancellation Push Button.
  - m) Tap Changer Supply Isolating Switch.
  - n) Sequence Selector Switch.
  - o) Out of Step Alarm with Cancellation Push Button.
  - p) Panel Strip Heater with Switch.
  - q) Panel Lamp with Door Switch.
  - r) Surge relay trip.
  - s) Upper limit & lower limit reached.
  - t) Two spare windows.
  - u) Buchholz relay alarm.
  - v) Buchholz relay trip.
  - w) Pressure relief device trip.
  - x) MOLG low oil level alarm.
- B) Terminal Block (for RTCC Panel and Cooler Control Cabinet) :**
- 1) **The terminal block shall be stud type.** The terminal blocks should be as per IEC 60947/7-1. **The insulating material should be polyamide and all the metal parts should be non ferrous.** The screws should be captive and terminal be shock protected. All terminals shall be clearly marked with identification numbers or letters to facilitate connection to external wiring.
  - 2) All internal wiring to be connected to the external equipment shall be terminated on terminal blocks, preferably **vertically mounted** on the side of each panel. The terminal blocks shall be **1100 V grade and have 10 amps continuous rating**, molded piece, complete with insulated barriers, **non-disconnecting stud type terminals**, washers, nuts and lock nuts. Terminal block design shall include a white fiber-marking strip with clear plastic, slip-on/clip-on terminal cover. Markings on the terminal strips shall correspond to wire number and terminal numbers on the wiring diagrams.
  - 3) Terminal blocks for current transformer secondary leads shall be provided with test links and isolating facilities. Also current transformer secondary leads shall be provided with short-circuiting and earthing facilities.
  - 4) At least 20% spare terminals shall be provided on each cubicle and these spare terminals shall be uniformly distributed on all terminal blocks.
  - 5) Unless otherwise specified, terminal blocks shall be suitable for connecting the following conductors on each side.
    - a) For all circuits except current transformer circuits: minimum of two nos. of 2.5 mm<sup>2</sup> copper.
    - b) For all CT circuits: minimum two nos. of 4 mm<sup>2</sup> copper.
  - 6) There shall be a minimum edge to edge clearance of 250 mm between the first row of terminal block and the associated cable gland plate. Also the clearance between two rows of terminal blocks shall be minimum 150 mm.



### Technical Specification of 5 MVA and 10 MVA Power Transformer

- 7) Arrangement of the terminal block assemblies and the wiring channel within the enclosure shall be such that a row of terminal blocks is run parallel and in close proximity along each side of the wiring duct to provide for convenient attachment of internal panel wiring. The side of the terminal block opposite the wiring duct shall be reserved for the owner's external cable connection. All adjacent terminal blocks shall also share this field wiring corridor. A steel strip shall be connected between adjacent terminal block rows at 450 mm intervals for support of incoming cables.

#### 6.7 OLTC and Diverter chamber Conservator tank :-

- a) Conservator should be volumetric capacity of at least 10 % of total volume of oil in the OLTC tank. Moreover the oil in conservator up to the minimum level mark on the oil level gauge should be at least 3 % of the total volume of oil in the OLTC. Conservator having a capacity between the highest and the lowest visible levels to meet the requirement of expansion of the total cold oil volume in the transformer and cooling equipment from the minimum ambient temperature i.e. -5 Deg. C to 98 Deg. C. Conservator for OLTC and Diverter chamber shall be single with partition inside and with clear visible indication for both OLTC and Diverter chamber.
- b) Flexible rubber bag (Air cell) should be provided inside of conservator tank for oil preservation system. Air cell material shall be special type of fabric coated with special grade nitrile rubber which outer surface is oil resistant and inner surface is ozone resistant. It shall be possible to remove or replace the Air cell if required.
- c) Conservator shall be bolted into position so that it can be removed for easy cleaning and other maintenance work. Main pipe from tank shall be projected about 20 mm above conservator bottom for creating a sump for collection of impurities. Conservator minimum oil level corresponding to minimum temperature shall be well above the sump level.
- d) Conservator shall be supported at minimum two points to OLTC tank.
- e) Conservator shall be mounted in such a way that the OLTC can be inspected / maintained without disturbing the conservator.
- f) Following fittings and accessories shall be provided on OLTC tank conservator:
  - i) Prismatic oil gauge with three position Normal, Minimum and Maximum marking.
  - ii) End cover.
  - iii) Oil feeling hole with cap.
  - iv) Magnetic Oil gauge with LOW LEVEL alarm
  - v) Silica Gel Dehydrating Breather with oil seal and filter . Container and oil cup should be polycarbonate single piece clearly transparent cover and resistant to UV rays
  - vi) Drain cum filling valve (Gate valve with locking rod and position indicator, made of Brass 25 mm with cover plate.
  - vii) Shut off valve (Gate valve) with position indicator made of Brass 80 mm located before and after OLTC Bucholz relay.





### Technical Specification of 5 MVA and 10 MVA Power Transformer

- viii) Flange for Breather connection.
- ix) Air release valve on conservator made of Brass 25 mm with cover plate.
- g) Breather body should be Aluminum pressure die cast, shot blasted and powder coated. Container and oil cup should be 143R grade UV resistant polycarbonate. All gaskets should be of nitrile cork (RC 70C) rubber. Breather should be flanged type . Breather piping shall not any valve placed in between conservator and breather. Breather shall be removable type mounted at suitable height from ground level. Breather shall be tested for 0.35 kg / cm for all joints. Silica Gel used in breather should be 2.5 mm diameter ROUND BALL type and should be bio-degradable, non-carcinogenic.

## 7.0 Protection & Measuring Devices

### i) Oil Conservator Tank

- a) The Conservator tank shall have adequate capacity between highest and lowest visible levels to meet the requirement of expansion of the total cold oil volume in the transformer and cooling equipment.
- b) The conservator tank shall be bolted into position so that it can be remove for cleaning purposes.
- c) The conservator shall be fitted with magnetic oil level gauge with low level electrically insulated alarm contact.
- d) Plain conservator fitted with silica gel breather.

### ii) Pressure Relief Device.

The pressure relief device provided shall be of sufficient size for rapid release of any pressure that may be generated in the tank and which may result in damage of the equipment. The device shall operate at a static pressure of less than the hydraulic test pressure of transformer tank. It shall be mounted direct on the tank. A pair of electrically insulated contract shall be provided for alarm and tripping

### iii) Buchholz Relay

A double float type Buchholz relay shall be provided. Any gas evolved in the transformer shall collect in this relay. The relay shall be provided with a test cock suitable for a flexible pipe connection for checking its operation. A copper tube shall be connected from the gas collector to a valve located about 1200 mm above ground level to facilitate sampling with the transformer in service. The device shall be provided with two electrically independent potential free contracts, one for alarm on gas accumulation and the other for tripping on sudden rise of pressure.

### iv) Temperature Indicator

#### a) Oil Temperature Indicator (OTI)

The transformers shall be provided with a micro switch contact type thermometer with 150 mm dial for top oil temperature indication. The thermometer shall have adjustable, electrically independent potential free alarm and trip contacts. Maximum reading pointer and resetting device shall be mounted in the local control panel. A temperature sensing element suitably located in a pocket on top oil shall be furnished. This shall be connected to the OTI by means



### Technical Specification of 5 MVA and 10 MVA Power Transformer

of capillary tubing. Accuracy class of OTI shall be  $\pm 1\%$  or better. One No electrical contact capable of operating at 5 A ac at 230 volt supply.

#### b) Winding Temperature indicator (WTI)

A device for measuring the hot spot temperature of the winding shall be provided. It shall comprise the following.

- i) Temperature sensing element.
- ii) Image Coil.
- iii) Micro switch contacts.
- iv) Auxiliary CTS, If required to match the image coil, shall be furnished and mounted in the local control panel.
- v) 150mm dial local indicating instrument with maximum reading pointer mounted in local panel and with adjustable electrically independent ungrounded contacts, besides that required for control of cooling equipment, one for high winding temperature alarm and one for trip.
- vi) Two number electrical contact each capable of operating at 5 A ac at 230 Volt supply.

#### 8.0 Oil :

##### A) Insulation Oil :

As per annexure – I attached.

The quantity of transformer oil excluding OLTC shall not be less than **3000** Ltrs for 5 MVA And **4500** Ltrs for 10 MVA Transformer. One sample of oil drawn from every lot of Power Transformer offered for inspection should be tested at NABL accredited lab for tests as listed under Table-1 of IS : 1866(2000). The cost of this testing should be included within the cost of the cost of Power Transformer.

#### 9 Oil Preservation Equipment: Oil Sealing

The oil preservation shall be diaphragm type oil sealing in conservator to prevent oxidation and contamination of oil due to contact with atmospheric moisture.

The conservator shall be fitted with a dehydrating filter breather. It shall be so designed that.

- i) Passage of air is through a dust filter & Silica gel.
- ii) Silica gel is isolate from atmosphere by an oil seal.
- iii) Moisture absorption indicated by a change in colour of the crystals of the silica gel can be easily
- iv) Breather is mounted not more than 1400 mm above rail top level.

#### 10.0 Bushing Insulators and Terminals:-

A) **Outdoor Type** : For outdoor type transformer vertically mounted porcelain bushing Insulators on top the transformer tank. The Main winding and Neutral leads shall be brought out through outdoor type of Bushings.

- i) Porcelain bushings shall be homogeneous, non-porous, uniformly glazed to brown colour and free from blisters, burns and other defects.
- ii) Stress due to expansion and contraction in any part of the bushing shall not lead to deterioration.
- iii) Bushing shall be designed and tested to comply with the applicable standards.



### Technical Specification of 5 MVA and 10 MVA Power Transformer

- iv) Bushing shall have non-ferrous flanges and hardware.
- v) Fittings made of steel or malleable iron shall be galvanized
- vi) Bushing shall be so located on the top of transformers that full flashover strength will be utilized.
- vii) Bushing shall be supplied with bi-metallic terminal connector/ clamp/ washers suitable for fixing to bushing terminal. and the Employers specified conductors.  
The connector/clamp shall be rated to carry the bushing rated current without exceeding a temperature rise of 55°C over an ambient of 50°C. The connector/clamp shall be designed to be corona free at the maximum rated line to ground voltage.
- viii) Bushing of identical voltage rating shall be interchangeable.
- ix) The insulation class of high voltage neutral bushing shall be properly coordinated with the insulation class of the neutral of the low voltage winding.
- x) Each bushing shall be so coordinated with the transformer insulation that all flashover will occur outside the tank.

#### B) Indoor Type

- i) The extended bushing bus bars shall be used for termination of HV & LV cables. HV & LV busing shall be housed in completely sealed metallic enclosure. The shape of the HV & LV cable box should be rectangular type. No radiator fins arrangement below the HV & LV cable boxes for smooth handling and connections of cables.
- ii) M.S sheet, weather, vermin and dust proof cable box ,with minimum 3 mm thickness fitted with required glands, of a suitable construction shall be provided with each transformer to accommodate HV and LV cables . The box shall have slopping roof. The interior white and exterior olive green paint shall be in accordance with the specification. . The degree of protection shall be IP-55 or better. All incoming cables shall enter the cable box from the bottom and the minimum 4mm thick, non-magnetic, gland plate shall not be less than 600mm from the base of the box. The gland plate and associated compartment shall be sealed in suitable manner to prevent the ingress of moisture from the cable trench – for those transformers which are used in partly indoor substation,
- iii) HV and LV cable boxes should be on opposite side. The clearances, dimensional, technical details for HV and LV cable boxes should be as per CBIP -317-2017.
- iv) LV side cable box suitable for 11 KV should be 1C or 3C x 300 sq. mm , 1 run for 5 MVA and 2 runs for 10 MVA )
- v) HV side cable size suitable for 33 kV should be 1C or 3 C x 240 sq. mm ,1 run for 5 MVA & 1 run for 10 MVA ) and for 22 KV side 1C or 3C X 240 sqmm. for 5 MVA and 1C or 3C X 300 sqmm for 10 MVA)
- vi ) LV Neutral shall be brought out at top cover & connect with 2 nos of 75 x 10 mm insulated sleeve up to bottom of the tank through proper insulation support.

#### C) Bushing Technical Parameters for Outdoor/Indoor Power Transformer :

- a) 36kV bushing: 630 Amp.
- b) 12kV bushing: 1000Amp.
- c) Dry and Wet power frequency withstand test for 1 minute



### Technical Specification of 5 MVA and 10 MVA Power Transformer

- i) For 33kV bushing : 50KV for 1 min.
- ii) For 11 kV busing : 28KV for 1 min.
- d) Angle of mounting: 90 deg.
- e) Cantilever withstand load : for 33kV & 11 KV bushing – as per standard
- f) Minimum creepage distance: 25 mm / kV.
- g) Protected creepage distance : At least 50% of total creepage distance.
  - i) Continuous current rating : Minimum 20% higher than the current corresponding to the minimum tap of the Power Transformer.
- h) Atmospheric protection for clamp and fitting of iron and steel : Hot dip galvanizing as per IS : 2633.
- i) Bushing terminal lugs in oil and air : Tinned copper.
- j) Sealing washer / Gasket ring : RC 70 C Nitrile cork / Nitrile Rubber.

#### 11.0 Marshalling Box Cubicle :

- i) Sheet steel, weather, vermin and dust proof marshaling box fitted with required glands, locks, glass door, terminal Board, heater with switch, illumination lamp with switch, water- tight hinged and padlocked door of a suitable construction shall be provided with each transformer to accommodate temperature indicators, terminal blocks etc. The box shall have slopping roof and the interior and exterior painting shall be in accordance with the specification. Padlock along with duplicate keys shall be supplied for marshaling box. The degree of protection shall be IP-55 or better.
- ii) The schematic diagram of the circuitry inside the marshaling box be prepared and fixed inside the door under a propone sheet.
- iii) The marshaling box shall accommodate the following equipment
  - a) Temperature indicators.
    - i) Winding Temperature Indicator
    - ii) Oil Temperature Indicator.
  - b) Terminal blocks and gland plates for incoming and outgoing cables.  
All the above equipment except c) shall be mounted on panels and back of panel wiring shall be used for inter-connection. The temperature indicators shall be so mounted that the dials are not more than 1600 mm from the ground level and the door (s) of the compartment(s) shall be provided with glazed window of adequate size. The transformer shall be erected on a plinth which shall be 2.5 feet above ground level.
  - iv) To prevent internal condensation, a metal clad heater with thermostat shall be provided. The heater shall be controlled by a MCB of suitable rating mounted in the box. The ventilation louvers, suitably padded with felt, shall also be provided. The louvers shall be provided with suitable felt pads to prevent ingress of dust.
  - iv) All incoming cables shall enter the kiosk from the bottom and the gland plate shall not be less than 450 mm from the base of the box. The gland plate and associated compartment shall be sealed in suitable manner to prevent the ingress of moisture from the cable trench.
    - 1) Material for construction of marshalling box : Construction of marshalling box should be stainless steel more than 316 grade with powder coating of 1.6mm with specified color shed.



### Technical Specification of 5 MVA and 10 MVA Power Transformer

- 2) Door hinges of marshalling box should be from inner side and should not be exposed to rain. Gland plate mounting should be from inside only.  
Digital temperature scanner. TB with LED for all TRIP & ALARM signals.
- 3) Major equipment required for marshalling box :
  - a) One digital scanner for ( OTI alarm, WTI alarm Fan ON + 4-20mA for OTI & WTI).
  - b) Dial type Gauge with alarm & TRIP contacts for LV WTI.
  - c) Other panel accessories as listed as listed in spec.
- 4) Gland plate Min.3mm thick detachable with knockout 6X1 inch.
- 5) Contact wired terminal block connect well TTB with LED shall be used for all TRIP & alarm terminals (TTB No. DDFL4ULR) TTB shall be of “Solid Link” type & TTB with “Glass fuse “ type will not be acceptable. POLYAMIDE Minimum 8 mm width 2nos DDFL4ULR with brass link & end plate for each alarm and tripping ( One spare for each).Disconnecting type for WTI CT stud type with screwdriver operated for others separated terminal blocks for protection and Fan control are essential.
  - a) WTI alarm and TRIP.
  - b) OTI alarm and Trip.
  - c) Buchholz relay alarm and trip.
  - d) OSR trip contacts
  - e) MOG low level alarm.
  - f) MOG on OLTC low level alarm.
  - g) PRV main tank trip.
  - h) PRV OLTC trip.
  - i) WTI and OTI relay contacts of the temperature scanner.
  - j) Contacts in addition to above as required by customer during drawing approvals. To be provided by supplier.
- 6) Signals to be wired to terminal block :
  - a) WTI CT.
  - b) NCT.
  - c) Sensor for temperature scanner.
  - d) Capillaries for WTI and OTI.
- 7) IP55 Ingress protection plus additional rain canopy to be provided. Continuous welding on joints, welding at regular intervals on joints and filling of gaps with use of M seal not accepted. Cable entry from bottom for all cables. Panel internal access from front only through front door double leaf with antitheft hinges. Panel back access not accepted. Separate mounting for marshalling box. Panel supply 240V AC, Single Phase, 50Hz.



### Technical Specification of 5 MVA and 10 MVA Power Transformer

- 8) Panel accessories :
  - a) Cubicle lamp with door switch and separate fuse/MCB.
  - b) Approved space heaters controlled by thermostat and separate fuse /MCB
  - c) Incoming fuse switch/MCB for the incoming supply.
  - d) Panel wiring diagram fixed on back of panel door on aluminum plate engraved fixed by rivet.
  - e) Stainless steel door handle with lock & additional facility for padlock.
  - f) Single phase power plug industrial type 15/5Amp. With MCB.
  - g) TTB for all trip commands.
- 9) Fan motor control if installed in marshalling box or separate fan control cubicle. Fan shall have wire guard on both the sides.
  - a) 2X50% fans.
  - b) Complete fan control with fuse switch, contactor, Bimetallic relay, in starter circuit with type 2 coordinated rating as per IS.
  - c) Automatic control from WTI contact.
  - d) Provision for manual controls both from local/remote.
  - e) Fan control cubicle should be separately mounted.
  - f) 2RC/2RS type bearings shall be used instead of ball bearings.
  - g) Fan enclosure shall have perforated sheet with holes at motor side.
  - h) Fan shall have wire guard on both sides.
  - i) Fan support enclosure shall be ground mounted & not take any support from transformer radiators.
- 10) Fan control shall be Scanner operated auto manual scheme required single contactor for common control. MPCB shall be suitable rating range for each fan with auxiliary contact. Fan identification numbers on both at MPCB and fan end. Standby fan logic in a day, standby fan shall run for 15minutes.
- 11) Wires & Cables (FRLSH) :
  - a) AC control wiring- 1.5sq.mm black.
  - b) Screened cable for PT100 sensor.
- 12) Illumination & Socket Shall be of LED type with 5/15A domestic socket with MCB for control & protection.
- 13) Hardware : M 16 size & below stainless steel and above M 16 Hot dip galvanized steel hardware shall be used for external purpose. Cadmium plated except special hardware frame parts and core assembly as per manufacturer's design hardware shall be used for internal purpose.
- 14) All oil Surge relays, Buchholz And Pressure release valve shall be fully Enclosed With Aluminum hoods / Canopy for protection against water ingress.
- 15) Gasket : RC 70 c Nitrile Cork / NBR 70 C shall be used for Transformer, OLTC chamber, PT chamber, surfaces interfacing with oil inspection cover etc. and also for Cable boxes, Marshaling box, OLTC drive mechanism etc.





### Technical Specification of 5 MVA and 10 MVA Power Transformer

#### 12) Valves :

- a) Material : Brass.
- b) Type : Both end flanged gate valve / butterfly valve depending on application.
- c) Size : As per manufacture standard.
- d) Position indicator, locking rod, padlocking facility, valve guard and cover late shall be provided to valves.

#### 13) Control Cable routing on Power Transformer:

Control cables for accessories on transformer tank to Marshalling box & WTI, OTI capillaries shall be routed through perforated Covered GI Trays.

Control cable shall be PVC insulated, extruded PVC inner sheathed, armoured, extruded PVC outer sheathed FRLS 1100 V grade control cable as per latest edition of IS 1554 part 1 minimum 2.5 sq mm for signals and 4 sq mm for CT with multistrand copper conductor.

The wires to be used inside marshalling box and OLTC drive mechanism Box shall be PVC insulated multistrand flexible copper wires of minimum 2.5 sqmm size, 1100 V grade FRLSH as per latest edition of relevant IS.

Cable routing from Transformer to Marshalling box should be done in such a way that adequate protection is available from mechanical and fire damage.

#### 14 RADIO INTERFERENCE AND NOISE LEVEL

Transformers shall be designed with particular care to suppress at least the third and fifth harmonic voltages so as to minimize interference with communication circuits. Transformer noise level when energized at normal voltage and frequency shall be as per NEMA stipulations.

#### 15 Painting of transformer, Conservator, OLTC, Radiator, Marshalling box:

- a) Surface preparation shall be done by 7 tank pretreatment process or shot blasting method.
- b) Finish on internal surfaces of the transformer interfacing with oil shall be painted with bright yellow heat resistant and oil resistant paint two coats. Paint shall neither react nor dissolve in hot transformer insulating oil.
- c) Frame parts shall be painted with bright Yellow heat resistant and oil resistant paint two coats. Paint shall neither react nor dissolve in hot transformer insulating oil.
- d) Finish on inner surface of the Marshalling box shall be done with white Polyurethane paint anti-condensation type two coats, minimum dry film thickness. 80 microns.



### Technical Specification of 5 MVA and 10 MVA Power Transformer

- e) Finish on outer surface of the transformer, conservator, radiator, cable boxes, marshalling box shall be **Olive Green (shade no.220, IS : 5 )** with one coat of primer & two coats of Polyurethane paint, minimum dry film thickness 120 microns paint.

#### 16.0 Minimum Protective devices on Power Transformer :

- 1) Spring loaded with detachable diaphragm type Pressure Relief Valve ( PRV) with two trip contacts for Main Tank of LSM model with limit switch design, IP : 65 with rain hood.
- 2) Spring loaded with detachable diaphragm type Pressure Relief Valve ( PRV) with two trip contacts for OLTC of LSM model with limit switch design, IP : 65 with rain hood.
- 3) Double Float Buchholz alarm Relay with alarm and trip contacts, service and test position with cock for the Main Tank. Terminal box shall be IP : 65 with drain plug for water draining. Additional rain hood shall be provided.
- 4) Oil Surge Relay with alarm and trip contacts, service and test position with cock for the OLTC. Terminal box shall be IP : 65 with drain plug for water draining. Additional rain hood shall be provided.

Oil temperature indicator metallic bulb type 150 mm diameter with maximum reading pointer, potential free independent adjustable alarm and trip contacts, resetting device with temperature sensing element.

- 5) Winding temperature indicator 150 mm diameter with maximum reading pointer, two sets of potential free independent adjustable alarm and trip contacts, resetting device with temperature sensing element, thermal image coil.
- 6) 2 Nos. Pt 100 sensors / RTDs for winding temperature indication wired up to TBs in marshalling box for external connection.

#### 17.0 Nitrogen injection Fire Protection System (NIFPS) ;

The Nitrogen injection Fire Protection System (NIFPS) is for 10 MVA Power Transformer Nitrogen injection Fire Protection System (NIFPS) shall use nitrogen as fire quenching medium. The protective system shall prevent Transformer/Reactor's oil tank explosion and possible fire in case of internal faults. In the event of fire by external causes such as bushing fire, OLTC fires, fire from surrounding equipments etc, it shall act as fast and effective fire fighter. It shall accomplish its role as fire preventer and extinguisher without employing water and/or carbon dioxide. Fire shall be extinguished within 3 minutes (Maximum) of system activation and within 3 seconds (Maximum) of commencement of nitrogen injection.

Detailed technical specification of NIFPS is as per Anx. II.





### Technical Specification of 5 MVA and 10 MVA Power Transformer

#### 18.0 Fittings and Accessories on Power Transformer:

The following fittings and accessories shall be provided on the transformers:

- i) Conservator with isolating valves, oil filling hole with cap and drain valve. The conservator vessel shall be filled with constant oil pressure diaphragm oil sealing system.
- ii) Magnetic type oil level gauge (150 mm diameter) with low oil level alarm contacts.
- iii) Prismatic/ toughened glass oil level gauge.
- iv) Silica gel breather with oil seal and connecting pipe complete with first fill of activated silica gel or Alumina mounted at a level of 1300 mm above ground level.
- v) A double float type Buchholz relay with isolating valve. Bleeding pipe and a testing cock, the test cock shall be suitable for a flexible (pipe connection for checking its operation). A 5mm dia. Copper pipe shall be connected from the relay test cock to a valve located at a suitable height above ground level to facilitate sampling of gas with the transformer in service. Interconnection between gas collection box and relay shall also be provided. The device shall be provided with two electrically independent ungrounded contacts, one for alarm on gas accumulation and the other for tripping on sudden oil surge. These contacts shall be wired upto transformer marshaling box. The relay shall be provided with shut off valve on the conservator side as well as on the tank side.

The oil connection from transformer tank to the Conservator Vessel shall be arranged at a rising angle of 3 to 9° to the horizontal up to the Buchholz Relay and shall consist of 50 mm. inside diameter pipe as per latest IS 3639 or equivalent International Standard.

- vi) Pressure relief devices (including pressure relief valve) and necessary air equalizer connection between this and the conservator with necessary alarm and trip contacts.
- vii) Air release plugs in the top cover.
- viii) Inspection cover, access holes with bolted covers for access to inner ends of bushing etc.
- iv) Winding temperature (hot spot) indicating device for local mounting complete in all respects. Winding temperature indicator shall have two set of contacts to operate at different settings:
  - a) To provide winding temperature high alarm
  - b) To provide temperature too high trip
- v) Dial thermometer with pocket for oil temperature indicator with one set of alarm and one set of trip contacts and maximum reading pointer.
- vi) Lifting eyes or lugs for the top cover, core and coils and for the complete transformer.
- vii) Jacking pads
- viii) Haulage lugs.
  - ix) Protected type mercury / alcohol in glass thermometer and a pocket to house the same.
  - x) Top and bottom filter valves on diagonally opposite ends with pad locking arrangement on both valves.
  - xi) Top and bottom sampling valves.
  - xii) Drain valve with pad locking arrangement
  - xiii) Rating and connection diagram plate.
  - xiv) Two numbers tank earthing terminals with associated nuts and bolts for connections to Employer's grounding strip.



### Technical Specification of 5 MVA and 10 MVA Power Transformer

- xv) Marshaling Box (MB)
  - xvi) Shut off valve on both sides of flexible pipe connections between radiator bank and transformer tank
  - xvii) Cooling Accessories:
    - a) Requisite number of radiators provided with :-
      - One shut off valve on top
      - One shut off valve at bottom
      - Air release device on top
      - Drain and sampling device at bottom
      - Lifting lugs.
    - b) Air release device and oil drain plug on oil pipe connectors.
  - xviii) Terminal marking plates for Current Transformer and Main Transformer
  - xix) On/Off Load Tap changer as specified in BOQ
  - xx) Oil Preservation Equipment
  - xvi) Oil Temperature indicator
- 19.0 Tests :**
- A) Type Tests:**
- 1) The transformer offered should have been successfully type tested at NABL laboratories, in line with standard and technical specifications, within the last 5 (five) years from the date of opening of Tender. The tenderer shall furnish the following type tests reports (alongwith General arrangement drawing, Rating and Diagram Plate and Internal Constructional drawing, Core & Core details with flux density calculations) alongwith the offer.
    - i) Impulse Voltage withstand Test chopped on the tail on all three LV & HV phases.
    - ii) Temperature Rise Test on Tap No. 17 ( i.e. –15% voltage Tap)
    - iii) Short circuit Test
    - iv) Noise level measurement.
  - 2) The type test reports should be submitted and got approved from the Chief Engineer (Testing & QC) before commencement of supply.
  - 3) In case of any of the following, the offer may be considered for placement of order.
    - i. If above tests are carried out beyond 5 years
    - ii. Impulse Voltage Withstand test, Short Circuit test, Temperature Rise Test carried and Noise level measurement out not from NABL approved Laboratory.
    - iii. If there is any change in the design/ type of old type tested transformers to be offered against this specification.
  - 4) In respect of the successful bidder, the purchaser reserves the right to demand repetition of some or all the type tests in presence of the purchaser's representative. In case the unit fails in the type tests, the complete supply shall be rejected. The



### Technical Specification of 5 MVA and 10 MVA Power Transformer

bidders are therefore requested to quote unit rates for carrying out each type test, which however, will not be considered for evaluation of the offer.

- 5) However, successful bidders have to carry out the type tests at the laboratories accredited by NABL before commencement of supply at their own expense on the sample drawn by the purchaser from the lot offered for first Stage Inspection.
- 6) If above tests are carried out beyond 5 years, then the offer may be considered for placement of order however, successful bidders have to carry out the said type tests before commencement of supply at their own expense.
- 7) If above tests are carried out on higher capacity of offered type transformer, then the offer is considered for placement of order. However, successful bidders have to carry out the said type tests on offered type transformers before commencement of supply at their own expense.
- 8) The bidder should not make any changes or alteration in the transformer design / type offered against the subject tender.
- 9) If there is any change in the design/ type of old type tested transformers offered against the subject tender, the purchaser reserves right to demand of repetition of the type tests on the transformer to be supplied against subject tender, without any extra cost. The type test reports of the same should got approved from Chief Engineer (Testing & QC).
- 10) After getting drawings approval of power transformer to be supplied against subject tender, successful bidders should got approved of type test reports from office of the Chief Engineer (Testing & QC), 5<sup>th</sup> Floor, Prakashgad, MSEDCL, Bandra. The original type test reports should be made available for verification.

#### **B. Routine Tests:**

All transformers shall be subjected to the following routine tests at the manufacturers works.

The tests are to be carried out in accordance with the details specified in IS 2026.

- 1) Measurement of winding resistance.
- 2) Ratio, polarity and phase relationship.
- 3) Impedance voltage.
- 4) Load losses.
- 5) No-load losses and No-load current.
- 6) Insulation resistance.
- 7) Measurement of Harmonic level on No Load current.
- 8) Induced over voltage withstand.
- 9) Separate source voltages withstand.
- 10) Duty cycle of On-load Tap Changer.



### Technical Specification of 5 MVA and 10 MVA Power Transformer

- 11) Oil leakage gas collection, oil surge and voltage tests on gas and oil actuated relays.

Following additional routine tests shall also be carried out on each transformer free of cost and the cost for these tests is deemed to have been included in the price quoted.

- a) Magnetic Circuit Test
- b) After assembly, each core shall be tested for 1 minute at 2000 Volts between all bolts, side plates, and structural steel work.
- c) Measurement of capacitance and tan delta to determine capacitance between winding & earth. This measurement shall be carried out before and after series of dielectric tests.
- d) Pressure Relief Device Test: The pressure relief device of each size shall be subjected to increasing oil pressure. It shall operate before reaching the test pressure specified in „Tank Tests'. The device shall be sealed off after the excess pressure has been relieved. High voltage withstand test shall be performed on auxiliary equipment and wiring after complete assembly.

#### A) Vacuum Test :

The tank of a Power Transformer (excluding tap changing compartment, radiators and coolers) shall be able to withstand a vacuum gauge pressure of 68.0 KN/sq.m. (500 mm. of Hg).

The permanent deflection of the flat plate after subjecting the transformer tank to the above vacuum for one hour shall not exceed the following values, without affecting the performance of the transformer.

Horizontal length of flat plate	Permanent deflection(mm)
Up to and including 750 mm	5.0
751 to 1250	6.5
1251 to 2000	8.5
2001 to 2250	11.0
2251 to 2500	12.5
2501 to 3000	16
Above 3000	19

#### B) Oil leakage Test :

The tank and oil filled compartments shall be tested for oil tightness completely filled with air or oil of viscosity not greater than that of insulating oil conforming to IS : 335 at the ambient temperature and applying a pressure equal to the normal pressure plus 35 KN/ m<sup>2</sup> measured at the base of the tank. The pressure shall be maintained for a period of not less than 12 hours of oil and one hour for air and during that time no leak shall occur.



### **Technical Specification of 5 MVA and 10 MVA Power Transformer**

#### **C) Pressure Test :**

Where required by the Employer, one transformer tank of each size together with its radiator, conservator vessel and other fittings shall be subjected to a pressure corresponding to twice the normal head of oil or to the normal pressure plus 35 KN / m<sup>2</sup> whichever is lower, measured at the base of the tank and maintained for one hour.

#### **D) Inspection of Insulation oil :**

To ascertain the quality of the transformer oil, the original manufacturer's test report should be submitted at the time of inspection. Also arrangements should be made for testing of transformer oil, after taking out the sample from the manufactured transformer and tested in the presence of MSEDCL representative or in an independent laboratory.

#### **20.0 Rejection :**

Apart from rejection due to failure of the transformer to meet the specified test requirements the transformer shall be liable for rejection on any one of the following reasons.

- i No load loss exceeds the values mentioned in Clause. No. 6.10 above.
- ii Load loss exceeds the specified values mentioned in Clause No. 6.10 above.
- iii Impedance voltage value exceeds the Guaranteed value plus tolerances as mentioned at clause No.6.8 above.
- iv Type test are not carried out as per clause no. 12, (A) of the specification.
- v Drawings are not submitted as per clause no. 16 of the specification.
- vi GTP not submitted as per clause no.20 of the specification.

#### **21.0 Quality Assurance:**

##### **1) Quality Assurance Program:**

Quality Assurance Program shall be submitted before contract award. Quality Assurance Program shall contain following :

- a) The structure of the organization.
- b) The duties and responsibilities assigned to staff ensuring quality of work.
- c) The system for purchasing, taking delivery and verification of material.
- d) The system for ensuring quality of workmanship.
- e) The system for control of documentation.
- f) The system for the retention of records.
- g) The arrangements for the Supplier are internal auditing.
- h) The tenderer shall submit the List of testing equipment available with them for testing the transformers for acceptance and routine tests as specified in the relevant standards and the present specification.



### Technical Specification of 5 MVA and 10 MVA Power Transformer

#### 2) Quality Plan :

Quality Plan shall be submitted by the successful bidder for approval of Chief Engineer (Testing & Q.C).

Quality Plan shall contain following as a minimum:

- a) An outline of the proposed work and program sequence.
- b) The structure of the Supplier's organization for the contract.
- c) The duties and responsibilities assigned to staff ensuring quality of work for contract.
- d) Hold and notification points.
- e) Submission of engineering documents required by specification.
- f) The inspection of material and components on receipt.
- g) Reference to the Supplier's work procedures appropriate to each activity.
- h) Inspection during fabrication and construction.
- i) Final inspection and test.
- j) Successful bidder shall submit Mills invoice, Bill of lading, Mill's test certificate for grade, physical tests, dimension and specific loss per kg for the core material to the Purchaser for verification in the quality plan suitably.
- k) Successful bidder shall submit outline of production, inspection, testing, packing, and dispatch documentation program.
- l) Successful bidder shall submit Copper / Aluminum conductor, Transformer oil, Core, Insulation, Porcelain bushing and Steel plate etc. materials test certificate.

#### 22.0 Detail Progress Report:

Detail Progress Report shall be submitted to Purchaser once in a month. Contains in Progress Report as below:

- a) Progress on Material procurement.
- b) Progress on fabrication.
- c) Progress on assembly.
- d) Progress on internal stage inspection.
- e) Reason for any delay in total program.
- f) Details of test failures if any in manufacturing stages.
- g) Progress on final box up.
- h) Constraints.
- i) Forward path.

#### 23.0 Drawing Approval:

The successful Bidders shall submit complete set of Drawings as as below in triplicate indicating dimensions to CE ( Testing & QC cell) for approval and get approved it before offering I st stage inspection. The drawings shall be of A-3 (420 x 297 mm) size only.

The bidder should not change design once offered as per A/T, Approved drawings and Type Test Reports.

- 1) Name plate drawing with terminal marking and connection diagram.
- 2) General Arrangement Drawing.



### Technical Specification of 5 MVA and 10 MVA Power Transformer

- 3) Internal Construction drawing.
- 4) Core & Core Details with flux density calculations.
- 5) Plug in HV Bushings assembly drawings and connector.
- 6) HV Bushings with creepage distance drawings.
- 7) LV Bushings assembly drawings.
- 8) LV Bushings with creepage distance drawings.
- 9) HV/LV cable box drawing.
- 10) Breather.
- 11) Foundation Plan.
- 12) Valve Schedule Drawing.
- 13) General Arrangement of Radiator.
- 14) General Arrangement of Marshalling Box with connection diagram with Fan Control Cubicle
- 15) Schematic diagram of Marshalling Box and Fan Control Cubicle.
- 16) Name plate drawing of OLTC.
- 17) Detail Arrangement of Tap Changer.
- 18) Breather of OLTC.
- 19) Tap Changer Phase Design.
- 20) Group Control of Tap Change Gear.
- 21) General Arrangement Drawing of Tap Changer Control.
- 22) General Arrangement Drawing of Nitrogen Injection Fire Protection System.
- 23) Schematic diagram of Nitrogen Injection Fire Protection System.
- 24) General Arrangement Drawing of RTCC Panel.
- 25) Bill of Material.
- 26) Packing List.
- 27) Quality Action Plan.

#### 24.0 Stage Inspection:

- 1) The inspection may be carried out by the purchaser at any stage of manufacture. The successful tenderer shall grant free access to the purchaser's representatives at a reasonable time when the work is in progress. Inspection and acceptance of any equipment under this specification by the purchaser shall not relieve the supplier of his obligation of furnishing equipment in accordance with the specifications and shall not prevent subsequent rejection if the equipment is found to be defective.
- 2) Supplier shall give 10 days advance intimation to the CE (Testing) and SE(MM) to organize stage inspection, Chief Engineer (Testing) will depute representatives from testing and inspection wing for the stage inspection.

#### Inspection and Testing during manufacture as below:

##### a) Tank and Conservator :

- i. Check correct dimensions.
- ii. Leakage Test of conservator as per CBIP manual .
- iii. Leakage Test on all tanks at normal head of oil plus 35 kN / sq. meter at the base of the tank for 24 hrs.
- iv. Vacuum and Pressure test on tank as per CBIP.
- v. Leakage test of radiators as per CBIP.





### Technical Specification of 5 MVA and 10 MVA Power Transformer

- b) Core :**
- i. Vendor shall submit the documentary evidence for procurement of CRGO laminations and prove that they have procured / used new core material.
  - ii. During in process inspection at lamination sub vendor, MSEDCL representative shall randomly select / seal lamination for Testing at ERDA / CPRI ( Accredited NABL labs ) for specific core loss, accelerated ageing test, surface insulation resistivity, AC permeability and magnetization, stacking factor, ductility etc. This testing shall be in the scope of Vendor.
  - iii. Check amount of burrs.
  - iv. Bow check on stamping.
    - v. Check for the overlapping of stampings. Corners of the sheet are to be apart.
  - vi. Visual and dimensional check during assembly stage.
  - vii. High voltage test ( 2kV for one minute) between core and clamps.
- c) Insulating Materials :**
- i. Sample check for physical properties of materials.
  - ii. Check of dielectric strength.
  - iii. Visual and dimensional checks.
  - iv. Check for the reaction of hot oil on insulating materials.
  - v. Certification of all test result
- d) Windings :**
- i. Sample check on winding conductor for mechanical properties and electrical conductivity.
  - ii. Visual and dimensional check on conductor for scratches, departmental mark etc.
  - iii. Sample check on insulating paper for PE value, Bursting strength, Electrical strength.
  - iv. Check for the reaction of hot oil on insulating paper.
  - v. Check for the bending of the insulating paper on conductor.
  - vi. Check and ensure that physical condition of all materials taken for winding is satisfactory and free of dust.
  - vii. Check for absence of short circuit between parallel strands.
  - viii. Check for Brazed joints wherever applicable.
  - ix. Measurement of voltage ratio to be carried out when core / yoke is completely restocked and all connections are ready.
  - x. Certification of all test results of winding / material.
- e) Check before drying process :**
- i. Check conditions of insulation on the conductor and insulation between windings.
  - ii. Check insulation distance between high voltage connection and earthed and other live parts.
  - iii. Check insulation distance between low voltage connection and earthed and other live parts.
  - iv. Insulation test of core earthing.
  - v. Check for proper cleanliness.





### Technical Specification of 5 MVA and 10 MVA Power Transformer

- vi. Check tightness of coil i.e. no free movement.
- vii. Certification of all test results.
- f) **Check during drying process :**
  - i. Measurement and recording of temperature and drying time during vacuum treatment.
  - ii. Check for completeness of drying.
  - iii. Certification of all test results.
- g) **Tests on fitting and accessories :**  
As per manufacture's standard.
- h) **Routine / Acceptance tests :**  
The sequence of routine testing shall be as follows:
  - i. Visual and dimension check for completely assembled power transformer.
  - ii. Measurement of voltage ratio.
  - iii. Measurement of winding resistance at principle tap and two extreme taps.
  - iv. Vector group and polarity tests.

#### 26.0 Final Inspection:

C.E. (MMD) will depute his representative ( IW representative) at the time of final inspection along with Testing Wing representative.

#### 27.0 Challenge Testing:

The manufacturer can also request challenge testing for any test based on specification and losses. The challenger would request for testing with depositing testing fees, transportation „To and Fro“ from MSEDCL site to laboratory. The challenger would have the opportunity to select the sample from the store and any such challenge should be made within the guarantee period. The party challenged, challenger and the utility could witness the challenge testing.

The challenge testing would cover following tests:

1. Measurement of magnetizing current.
2. No load losses test.
3. Load losses test (at 100 % loading).
4. Temperature rise test.

The challenge test could be conducted at NABL Laboratory, like ERDA and CPRI. If the values are within the limits the products gets confirmed else not confirmed.

Following scenarios will be considered.

- 1) If the product is confirmed, the challenger has to bear the testing and transportation cost. Deposit amount will be forfeited.
- 2) If the product is not confirmed-
  - a) The manufacturer must pay the testing and transportation charges to challenger within 30 days from the reporting date.
  - b) Entire quantity supplied to MSEDCL will be considered as non confirming. Penalty of 1.5 times the testing fees and transportation „To and Fro“ from MSEDCL site to laboratory charges for all Power Transformer will be levied on the manufacturer.



### Technical Specification of 5 MVA and 10 MVA Power Transformer

- c) The manufacturer will be prohibited from participating in tenders for next 5 years.
- d) Deposit will be returned to challenger by MSEDCL within 30 days.
- e) In case of heat run test (Temperature rise test), penalty will be INR 5 lacs per degree centigrade for the additional temperature rise in degree Celsius.

### 28.0 Guaranteed & Technical Particulars:

The bidder should fill up all the details in Schedule A and the statement such as “as per drawings enclosed”, “as per MSEDCL requirement” “as per IS” etc. shall be considered as details not furnished and such offers liable for rejection.

### 29.0 Performance Guarantee:

All Power transformers supplied against this specification shall be guaranteed for a period of 66 months from the date of receipt at the consignee’s Sites or 60 months from the date of commissioning, whichever is earlier. However, any engineering error, omission, wrong provisions, etc. which do not have any effect on the time period, shall be attended to as and when observed/ pointed out without any price implication.

### 30.0 Cost Data Sheet :

The bidders shall submit the cost data sheets indicating the break up prices and quantity of each raw material and components along with the unit rates required for manufacture the offered transformers along with the offer. The cost data sheet format is enclosed herewith. If the rates quoted are not justified with the cost data sheets, the offer shall not be considered for evaluation and placement of the order. The cost data sheets shall be scrutinized by MM cell section.

Format for Cost Data-Item ----- kVA ,----- kV Power Transformer					
Sr.No.	Particulars	Unit	Unit Rate (Rs)	Qty.	Amt (Rs.)
1	Core (M4 or better )	kg			
2	Copper for HV Winding	kg			
3	Copper for LV Winding	kg			
4	Insulation Paper	meters			
5	Oil	ltrs			
6	Tank	No.			
7	Channel	kg			
8	Radiator	kg			
9	Insulator / Bushing				
10	N2 Based Fire Protection System				
11	On Load Tap Changer with RTCC Panel				
12	Wastages@%	Lum Sum			

**Technical Specification of 5 MVA and 10 MVA Power Transformer****31.0 Schedules :**

a) The bidder shall fill in the following schedules which form part of the tender specification and offer. If the schedules are not submitted duly filled in with the offer, the offer shall be rejected.

Schedule `A' -Guaranteed Technical Particulars

Schedule `B' -Schedule of Tenderer's Experience.

Schedule `C' –Format for undertaking of use of imported prime CRGO steel laminations.

b) The discrepancies between the specification and the catalogs, Literatures and indicative drawings which are subject to change, submitted as part of the offer, shall not be considered and representation in this regard will not be entertained.

c) The Bidder shall submit the list of orders for similar type of equipments, executed or under execution during the last three years, with full details in the schedule of Tenderer's experience (Schedule `B') to enable the purchaser to evaluate the tender.

d) The bidder should submit undertaking for use of imported prime CRGO material with documentary evidence.



**Technical Specification of 5 MVA and 10 MVA Power Transformer**

**Schedule 'A'**

**PRINCIPAL TECHNICAL PARAMETERS:**

Guaranteed Technical Particulars For 5 MVA & 10 MVA, 33/11KV Power Transformer.

Sr. No	PARTICULARS	MSEDCL REQUIREMENT	Technical Parameters
1	Brand Name & Manufacturer's Name	Mfg. to give detail	
2	Place of manufacturer	Mfg. to give detail	
3	Type (Indoor/Outdoor)	Indoor/Outdoor	
4	Normal KVA output	Mfg. to give detail	
a.	Continuous max. KVA rating as per IS 2026/1977 amended to date corresponding to a temp. rise of 50 deg. C (in oil) under max. Ambient temp. of 50 deg. C	Mfg. to give detail	
b.	Continuous max. KVA rating at site corresponding to 50 deg. C temp rise in oil with max. ambient temp of 50 deg. C	Mfg. to give detail	
5	Maximum Temperature rise for top oil over an ambient temperature of 50 °C should be 50 °C maximum (measured by thermometer in accordance with IS 2026 or relevant International Standard).	50 °C	
6	Maximum Temperature rise for winding over an ambient temperature of 50 °C should be 55 °C maximum (measured by resistance method in accordance with IS 2026 or relevant International Standard).	55 °C	
7	No. of phases	3	
8	Voltage between phases (HV Side) at normal tap 5, in volts	Mfg. to give detail	
9	Voltage between phases (LV Side) at normal tap 5, in volts	Mfg. to give detail	
9	Connections		
a.	On HV	Mfg. to give detail	
b.	On LV	Mfg. to give detail	



**Technical Specification of 5 MVA and 10 MVA Power Transformer**

10	Vector group	Dyn11	
11	Frequency	50 Hz with $\pm 3\%$ tolerance	
12	Tapings		
	i) Range	+5 % to -15 % in	
	ii) No. of steps	16 (of 1.25 % each)	
13	Method of cooling	ONAN	
14	Max. core losses at normal voltage & normal frequency-KW (without IS Tol.)	Mfg. to give detail	
15	Max. losses at max. voltage or at 110% voltage at normal frequency - KW (without IS Tol.)	Mfg. to give detail	
16.	Max. load losses at normal full load current- KW at 75 deg. C	Mfg. to give detail	
17	Resistance voltage drop of full load at normal tap at 75 deg. C in volts		
18	% Reactance drop on full load at normal tap at 75 deg. C	Mfg. to give detail	
19	% Impedance Voltage drop on full load at normal tap at 75 deg. C	Mfg. to give detail	
20	Current Density		
a.	Primary winding Amps per sq.mm.(Main & Tap)	Mfg. to give detail	
b.	Secondary winding Amps per sq.mm.	Mfg. to give detail	
21	Winding Resistance per phase in ohms at 75 deg..C	Mfg. to give detail	
a.	HV Winding ( main & Tap )	Mfg. to give detail	
b.	LV Winding	Mfg. to give detail	
22	No. of turns	Mfg. to give detail	
a.	HV Winding ( Main & Tap )	Mfg. to give detail	
b.	LV Winding	Mfg. to give detail	
23	Core	Mfg. to give detail	
24	Grade of laminations & type of core	Mfg. to give	



**Technical Specification of 5 MVA and 10 MVA Power Transformer**

		detail	
25	Core material used & thickness	Mfg. to give detail	
26	Type of core construction	Mfg. to give detail	
27	Winding insulation details	Mfg. to give detail	
25.1	Type of insulation of winding	Mfg. to give detail	
a.	HV side	Mfg. to give detail	
b.	LV side	Mfg. to give detail	
25.2	Class of insulation winding	Mfg. to give detail	
a.	HV side	Mfg. to give detail	
b.	LV side	Mfg. to give detail	
26	Guaranteed efficiency at standard reference temp. of 75 deg. C & normal voltage ratio in %	Mfg. to give detail	
a.	on 100% load at 1 p. f.	Mfg. to give detail	
b.	on 75% load at 1 p. f.	Mfg. to give detail	
c.	on 50% load at 1 p. f.	Mfg. to give detail	
d.	on 100% load at 0.8 lag p. f.	Mfg. to give detail	
e.	on 75% load at 0.8 lag p. f.	Mfg. to give detail	
27	Regulation on full load at 75 deg. C & normal voltage ratio in %	Mfg. to give detail	
a.	at 1 p.f.	Mfg. to give detail	
b.	at 0.8 p.f.(lag)	Mfg. to give detail	
28	Min. Clearance to earth	Mfg. to give detail	
a.	of primary winding in mm	Mfg. to give detail	
b.	of secondary winding in mm	Mfg. to give	



**Technical Specification of 5 MVA and 10 MVA Power Transformer**

		detail	
29	Impulse withstand voltage on high tension winding (stating nature of impulse ) KV	Mfg. to give detail	
30	Type of tank	Mfg. to give detail	
31	Total radiating surface sq.mt. (i.e. radiators, tank-tank body & top cover ). Furnish the calculations	Mfg. to give detail	
31.1	Heat generated by the transformer for the given losses in joules, furnish the calculations	Mfg. to give detail	
32	Noise level at a distance of 1 m.	Mfg. to give detail	
33	Weight in Kg	Mfg. to give detail	
a.	Weight of core	Mfg. to give detail	
b.	Weight of copper in primary (HV).(Main & Tap ) per phase	Mfg. to give detail	
c.	Weight of copper in secondary (LV) per phase	Mfg. to give detail	
d.	Weight of core coil assembly	Mfg. to give detail	
e.	Weight of lift for inspection (top cover)	Mfg. to give detail	
f.	Weight of conservator with oil	Mfg. to give detail	
	Weight of conservator without oil	Mfg. to give detail	
g.	Weight of tank with radiators	Mfg. to give detail	
h.	Weight of tank with oil & Term. Boxes (HV/LV)	Mfg. to give detail	
i.	Weight of one radiator with oil	Mfg. to give detail	
	without oil	Mfg. to give detail	
j.	Weight of OLTC with oil	Mfg. to give detail	
	without oil	Mfg. to give detail	
k.	Weight of HV Cable Box	Mfg. to give detail	
	Weight of LV Cable Box	Mfg. to give	



### Technical Specification of 5 MVA and 10 MVA Power Transformer

		detail	
l.	Weight of Oil only	Mfg. to give detail	
	In Tank	Mfg. to give detail	
	In OLTC	Mfg. to give detail	
	In Conservator	Mfg. to give detail	
m.	Weight of transformer complete with oil & all accessories	Mfg. to give detail	
34	Quantity of Oil Liters	Mfg. to give detail	
a.	In Tank	Mfg. to give detail	
b.	In Conservator	Mfg. to give detail	
c.	In OLTC	Mfg. to give detail	
35	Overall dimensions when installed ( with accessories fitted)		
a.	Length (mm) 5200 mm	Mfg. to give detail	
b.	Width (mm) 4200 mm	Mfg. to give detail	
c.	Height (mm) 5800 mm	Mfg. to give detail	
36	Transport dimensions (L x Wx H)		
a.	Length (mm)	Mfg. to give detail	
b.	Width (mm)	Mfg. to give detail	
c.	Height (mm)	Mfg. to give detail	
37	Head room necessary to allow removal of core in meters	Mfg. to give detail	
38	Available clear space of 1 m ( considering the size of transformer bay & overall dimensions of transformer ) req. all round for adequate ventilation is sufficient		
39	OLTC	Mfg. to give detail	
39.1	Details of OLTC Gear	Mfg. to give	





**Technical Specification of 5 MVA and 10 MVA Power Transformer**

		detail	
a.	MVA Rating	Mfg. to give detail	
b.	Current Rating	Mfg. to give detail	
c.	Voltage Ratio	Mfg. to give detail	
d.	Type of connection	Mfg. to give detail	
39.2	Particulars of OLTC gear offered make & type of the OLTC. Performance certificates attached (Yes/No)	Mfg. to give detail	
39.3	Type & Routine test certificates from CPRI attached (Yes/No)	Mfg. to give detail	
a.	Overall dimensions	Mfg. to give detail	
b.	Step voltage	Mfg. to give detail	
c.	Max. Working current	Mfg. to give detail	
d.	Direction of power flow	Mfg. to give detail	
e.	Value & Wattage of transition resistor	Mfg. to give detail	
40	Type test certificates in respect of 5/10 MVA transformer with voltage class 33 KV and 22 KV	Mfg. to give detail	
41	List of supplier of raw materials like copper, core, transformer oil, insulating materials etc. Details about quality control methods adopted to assess the quality of raw/ finished material.	Mfg. to give detail	
42	List of plant machinery & testing equipments indicating their ratings & make, for carrying out all routine/acceptance tests & certain type tests such as Heat Run at full load, Impulse test , Noise level measurement etc.	Mfg. to give detail	
43	Drawings:	Mfg. to give detail	
a.	Dimensional drawings of the transformer with radiators, conservators etc. fitted. General arrangement drawing one sheet comprising of plan, elevation, side view of the complete transformer & other details like legends, untanking height, clearance etc. also all above drawings in separate sheets.	Mfg. to give detail	
b.	Transport outline of the transformer including transport weight	Mfg. to give detail	



**Technical Specification of 5 MVA and 10 MVA Power Transformer**

c.	Rating & Diagram plate. Connection diagram of the transformer winding showing the position of tapping etc.	Mfg. to give detail	
d.	Bushings (primary & secondary) drawings.	Mfg. to give detail	
e.	Cable box assembly (LV) drawing along with support arrangement	Mfg. to give detail	
f.	Cable box assembly (HV) drawing alongwith support arrangement	Mfg. to give detail	
g.	Dimensional drawings of the OLTC gear (internal details).	Mfg. to give detail	
h.	Schematic diagram of the OLTC arrangement for Transformer operating independently.	Mfg. to give detail	



**Technical Specification of 5 MVA and 10 MVA Power Transformer**

## Schedule 'B'

### SCHEDULES OF TENDERER'S EXPERIENCE

Tenderer shall furnish here a list of similar orders executed/under execution by him to whom a reference may be made by Purchaser in case he considers such a reference necessary.

Sr. No.	Name of Client and Description of Item	Value of Order	Period of Supply and commissioning	Name and Address to whom Reference may be made
1	2	3	4	5

NAME OF FIRM \_\_\_\_\_

NAME & SIGNATURE OF TENDERER \_\_\_\_\_

DESIGNATION \_\_\_\_\_

DATE \_\_\_\_\_



**Technical Specification of 5 MVA and 10 MVA Power Transformer**

# **Annexure 'I' Technical Specification For Transformer Oil**



Maharashtra State Electricity Distribution Company Limited

---

TECHNICAL SPECIFICATION NO. MSC /2019/ 01

TECHNICAL SPECIFICATION

FOR

**NEW INSULATING OIL as per IS 335 amended 2018**

FOR

**Transformers**

IN

MSEDCL



**Technical Specification of 5 MVA and 10 MVA Power Transformer**

**I N D E X**

Specifications for New Insulating Oil	
Clause No.	Contents
1.	Scope
2.	Service Condition
3.	Reference Standards
4.	General Technical Requirements
5.	ISI Certification mark
6.	Packing
7.	Sampling
8.	Tests
9.	Pre- dispatch Inspection
10.	Testing Facility
11.	Rejection
12.	Quality Assurance
13.	Qualifying Requirement
Specifications for Drums, Large, fixed Ends Grade “A ” Drums	
Clause No.	Contents
1.	Scope
2.	Reference
3.	Terminology
4.	Capacity
5.	Dimensions
6.	Material
7.	Construction
8.	Finish
9.	Tests
10.	Sampling
11.	Marking



**Technical Specification of 5 MVA and 10 MVA Power Transformer**

12.	Schedules <ol style="list-style-type: none"><li>1. Schedule A - Guaranteed Technical Particulars.</li><li>2. Schedule B – Tenderer’s Experience</li></ol>
-----	--



**Technical Specification of 5 MVA and 10 MVA Power Transformer**

**TECHNICAL SPECIFICATION NEW INSULATING OIL  
SPECIFICATION NO. MSC/2019/01**

**1.0 Scope :**

**1.1** The specification covers manufacturing, sampling, testing, packing, marking and delivery of premium grade **Unused Mineral Insulating Oil (Type II)** for Transformers.

**1.2** This specification prescribes the requirements of new insulating oil suitable for use as an insulating and heat transfer medium.

**1.3** The Unused Mineral Insulating Oils are obtained by distillation and refining of crude petroleum.

**1.4** The Unused Mineral Insulating oils shall be with normal oxidation resistance.

**2.0 Service Conditions:**

A) The Unused Mineral Insulating oil to be supplied against this specification shall be suitable for satisfactory continuous operation of power and distribution transformers under the following tropical conditions.

2.1 Maximum ambient temperature (Degree C)	....	50
2.2 Maximum temperature in shade (Degree C)	....	45
2.3 Minimum temperature of air in shade (Degree C)	....	3.5
2.4 Relative Humidity (%)	....	10 to 100
2.5 Maximum Annual Rainfall (mm)	....	1450
2.6 Maximum Wind Pressure (Kg/Sq.)	....	150
2.7 Maximum altitude above mean sea level (meter)	....	1000
2.8 Isoceraunic level (days/year)	....	50
2.9 Seismic level (Horizontal acceleration)	....	0.3

Moderately hot and humid tropical climate conducive to rust and fungus growth.

2.10 Reference Ambient Temperature for temperature rise : 50 Deg C

B) The climatic conditions are prone to wide variations in ambient conditions and hence the Unused Mineral Insulating oil shall be of suitable for satisfactory continuous operation of power and distribution transformers.

**3.0 Reference Standards:**

3.1 Unless otherwise specified, the Unused Mineral Insulating oil to be supplied shall be conformed to Indian and International Standards amended up to date as follows:

Sr. No.	IS No.	Title
1	335/2018	New Insulating Oils - Specification (fifth revision)
2	1070 : 1992	Reagent grade water – specification ( third revision)
3	1448:[P:10/sec	Methods of test for petroleum and its products : Part 2



**Technical Specification of 5 MVA and 10 MVA Power Transformer**

	2]:2013	Acidity ( Second revision)
4	1448:[P:10]: 2013	Methods of test for petroleum and its products : Part 10 cloud point and pour point ( First revision)
5	1448:[P:16]: 2014 & 1448:[P:21]: 2012	Methods of test for petroleum and its products: Part 21 Flash Point ( closed) by Pensky Martens apparatus (Third revision)
6	1448:[P:25]: 1976	Methods of test for petroleum and its products: part 25 Determination of kinematics and dynamic viscosity ( First revision)
7	16084 :2013	Mineral Insulating Oils- determination of kinematics viscosity at very low temperatures.
8	1783:[Part1]: 1983	Drums, large, fixed ends: Part 1 Grade A Drums ( second revision)
9	1783:[Part 2]: 1988	Drums, large, fixed ends: Part 1 Grade A Drums ( third revision)
10	4759:1984	Hot-dip zinc coatings on structural steel and other allied products ( second revision)
11	6103:1971	Methods of test for specific resistance (resistivity) of electrical insulating liquids
12	ASTMD 971	Methods of test for interfacial tension of oil against water by the ring method.
13	6262:1971  16086 : 2013	Method of test for power factor and dielectric constant of electrical insulating liquids.  Insulating liquids – determination of the dielectric dissipation factor by measurement of the conductance and capacitance – test method.
14	6272:1971	Metal polishes (special)
15	6792:1992  6792:2017	Method for determination of electric strength of insulating oils  Insulating liquids – determination of the breakdown voltage





### Technical Specification of 5 MVA and 10 MVA Power Transformer

		at power frequency – test method (second revision)
16	6855:2017	Method of sampling for liquid dielectric (second revision)
17	12177:1987	Methods of test for oxidative ageing of electrical insulation of petroleum oils by the open beaker method
18	12463:1988	Inhibited mineral insulating oils
19	IEC 60814/1997	Determination of water in insulating liquids and in oil-impregnated paper and press board by automatic coulometric Karl Fischer titration – Method of test
20	13631:2017	Method of test for detection and determination of antioxidant additives in insulating oils.(revision first)

3.2 In case of conflict arising out due to variations between the applicable standard and the standards specified herein the provisions of this specification should prevail.

#### 4.0 General Technical Requirements:

The characteristics of the Unused Mineral Insulating oil when it is sampled at manufacturer's work or at the point of delivery and tested in accordance with the methods referred to in TABLE 2 of IS: 335: 2018 amended upto date.

#### 4.1 Function :-

- i) The Viscosity of Unused Mineral Insulating oil shall be **maximum 15 (mm<sup>2</sup>/ s)** at 40 ° C as per IS 1448 [ P:25]:1976.
- ii) The Viscosity of Unused Mineral Insulating oil shall be maximum **1800 (mm<sup>2</sup>/ s)** at 0 ° C as per IS 1448 [ P:25]:1976.
- iii) Pour Point of the Unused Mineral Insulating oil should be minimum 10 ° C below the Lowest Cold Start Energizing Temperature (LCSET) i.e. - **10 ° C** as per IS: 1448 [ P:10. Sec 2]:1970.
- iv) The Water content in the Unused Mineral Insulating oil shall be maximum **30 mg / kg** for bulk supply and **40 mg / kg** for delivery in drums as per IEC: 60814.
- v) As per IS 6792:1992 the Breakdown voltage of Unused Mineral Insulating oil shall be as follows.
  - a) The Breakdown voltage of Unused Mineral Insulating oil should be minimum **30 KV (rms) at.2.5 mm gap.**
  - b) The Breakdown voltage of **before Laboratory treatment** should be minimum **70 KV (rms) after Laboratory treatment at 2.5 mm gap.**
- vi) The Density of Unused Mineral Insulating oil shall be **maximum 0.895 g / cm<sup>3</sup> at 20 ° C** as per IS 1448 [ P:16]:1990.



### Technical Specification of 5 MVA and 10 MVA Power Transformer

- vii) As per IS: 16086 the Dielectric Dissipation Factor (DDF ) of Unused Mineral Insulating oil shall be maximum **0.005** ( $\tan \delta$ ) at  $90^\circ \text{C}$  .
- viii) Particle Content in drum at delivery of the Unused Mineral Insulating oil is as per IS : 13236.

#### 4.2 Refining / Stability :-

- i) The appearance of the Unused Mineral Insulating oil shall be clear, free from sediments (impurities) and suspended matter.
- ii) The Unused Mineral Insulating oil should be Neutral and free from any acidic compound. Total Acidity of Unused Mineral Insulating oil shall be maximum **0.01 mg/KOH/gm** as per IEC : 62021 – 1.
- iii) Interfacial tension of the Unused Mineral Insulating oil shall be minimum 40mN / m as per ASTM D971.
- iv) Total sulphur content in the Unused Mineral Insulating oil shall be maximum 0.05 % before oxidation test. as per ISO 14596 or ASTM D4294.
- v) The Corrosive Sulphur in the Unused Mineral Insulating oil shall be **Non-Corrosive**. The Corrosive Sulphur in the Unused Mineral Insulating oil shall be measured as per DIN 51353.
- vi) The Potential Corrosive Sulphur in the Unused Mineral Insulating oil shall be **Non-Corrosive**. The Potential Corrosive Sulphur in the Unused Mineral Insulating oil shall be measured as per IS : 16310.
- vii) Dibenzyl Disulfide (DBDS) in the Unused Mineral Insulating oil should not be detectable ( $< 5 \text{ mg / kg}$ ) as per IS : 16497 ( Part 1 ).
- viii) The Unused Mineral Insulating oil should be uninhibited ( U ) as per IS : 13631 / IEC : 60666. Inhibited in the Unused Mineral Insulating oil should not be detectable ( $< 0.01 \%$ ) as per IS : 13631 / IEC : 60666.
- ix) Metal Passivator additives in the Unused Mineral Insulating oil should not be detectable ( $< 5 \text{ mg / kg}$ ) as per IS : 13631 / IEC : 60666.
- x) Oxidation Stability can be improved by incorporation of Antioxidant additive in the Unused Mineral Insulating oil. Oxidation Stability is measured in accordance with IS : 12422.
- xi) 2- Furfural and related compound content in the Unused Mineral Insulating oil should not be detectable ( $< 0.05 \text{ mg / kg}$  for each individual compound ) as per IS : 15668.

#### 4.3 Performance :-

- i) Oxidation Stability can be improved by incorporation of Antioxidant additive and metal passivator additives in the Unused Mineral Insulating oil. Oxidation Stability is measured in accordance with IS : 12422 with Test Duration 164 hrs. At the end of Oxidation Stability Test following limits should be observed:
  - a) Total acidity : Maximum 1.2 mg KOH / gm.
  - b) Sludge : Maximum 0.8 %.
  - c) Dielectric Dissipation Factor ( DDF ) at  $90^\circ \text{C}$  : Maximum 0.500.
- ii) Gassing Tendency is caused in equipment with high electrical field stress or special design , gasses formed when subjected to Corona Partial Discharges and shall be absorbed



### Technical Specification of 5 MVA and 10 MVA Power Transformer

by the Unused Mineral Insulating oil, Gassing Tendency shall be as per IEC : 60628, Method A.

- ii) Stray Gassing means production of gasses such as hydrogen, hydrocarbons carbon oxides at low temperatures ( $< 120^{\circ} \text{C}$ ) without thermal or electrical faults in transformer, sometimes even without operational stress. This phenomenon could result in high production of gases and a misinterpretation of Dissolved Gas Analysis ( DGA ) results.
- iii) Electrostatic Charging Tendency ( ETC ) of the Unused Mineral Insulating oil is an important for certain design of HV transformer which have oil pumping rates that can give rise to the build- up of electrostatic charge. This can result in energy discharge causing transformer failure. Electrostatic Charging Tendency ( ETC ) can be reduced by using metal passivator additives such as Benzotriazole ( BTA ) and 5-methyl-1H-Benzotriazole ( TTA ). Electrostatic Charging Tendency ( ETC )'s measurement as per CIGRE Technical Brochure 170.

#### 4.4 Health, Safety and Environment ( HSE ) :-

- i) Flash point of the Unused Mineral Insulating oil measured by Pensky Marten apparatus shall be **minimum 135 ° C** as per IS: 1448 [ P:21]:1992.
- ii) Polycyclic Aromatics ( PCA ) content of the Unused Mineral Insulating oil detectable by extraction with Dimethylsulfoxide ( DMSO ) under the condition of IP 346, shall be maximum 3 % .
- iii) Polychlorinated Biphenyls ( PCB ) content of the Unused Mineral Insulating oil should not be detectable ( $< 2 \text{ mg / kg}$ ) as per IS : 16082.

#### 5.0 ISI Certification mark for Unused Mineral Insulating oil:-

The Unused Mineral Insulating oil is to be supplied confirming to IS-335-2018 as amended upto date should bear ISI certification mark, without ISI mark insulating oil will rejected.

#### 6.0 Packing :-

- 6.1 The Unused Mineral Insulating oil shall be delivered in perfectly clean steel drums of 210 liters nominal capacity conforming to Grade "A" type 2 conforming IS: 1783 ( Part 1 ) : 1993 amended upto date. The drum shall be coated from inside with epoxy lacquer of phosphate coating or better. The inside coating of the drum shall be resistant to Unused Mineral insulating oil. The outside surface of the drum may be coated with anticorrosive primer and finish paint, for protection against atmospheric corrosion. The colour of the finishing paint shall be Navy Blue (Shade No. 106) conforming to IS:5:1994 (Colours of ready mixed paints). The drum shall be effectively sealed immediately after filling the oil to avoid ingress of moisture.

#### 6.2 Steel Barrel:-

The Unused Mineral Insulating oil of above specification shall be supplied in standard packing of 200 liters nominal capacity, non-returnable Brand New Steel Barrels (Drums) 'A' grade type-2 conforming to IS-1783 (Part-I) 1993 as amended upto date.



### Technical Specification of 5 MVA and 10 MVA Power Transformer

*The Type-2 drums shall be as per Fig-2 with triple / Spiral seam (Drawings No. MSEDCL/MM-II/OIL/01 and MSEDCL/MM-II/OIL/02 ) with ISI marking.*

#### 7.0 Sampling :

Sampling of Unused Mineral Insulating oil shall be done in accordance with IS 6885: 1973.

#### 8.0 Tests :

The tenderer shall submit Test reports of the offered Unused Mineral Insulating oil with the offer in electronic format (i.e. Pen Drive) and in physical format. The tests shall be carried out at laboratories accredited by National Accreditation Board for testing and Calibration Laboratories (NABL) such as CPRI/ERDA to prove the requirements specified in this specification & as per relevant standards IS:335, 2018 amended up-to-date. The tests should be carried out within 5 years prior to the date of opening of this tender. The offer without test reports from NABL laboratories is considered as non- responsive and likely to be rejected.

The successful tenderer shall get approved the test reports of Unused Mineral Insulating oil and drum from Chief Engineer (MMC), MSEDCL, Prakashgad, Bandra, Mumbai prior commencement of the supply. The Drum drawings shall be submitted to the Chief Engineer (MMC) and get approved before commencement of the supply.

#### 9.0 Pre dispatch Inspection:

The tenderers should arrange for sample testing of Unused Mineral Insulating oil twice during the contractual period, at their cost. Tenderer's should note that no separate testing charges will be payable by the MSEDCL. Sample testing will have to be arranged as and when directed by the MSEDCL at CPRI, Bangalore/ERDA, Vadodara Laboratories.

#### 10.0 Testing Facility :

**10.1** The tenderer should have adequate testing facility for all routine and acceptance tests on Unused Mineral Insulating oil and should provide the testing arrangements and testing equipments to testing Engineer of MSEDCL. The tenderer should submit the list of testing equipments available with them with the offer.

**10.2** The bidder should also supply along with his offer the pamphlets/literatures in respect of Unused Mineral Insulating oil available with them.



### Technical Specification of 5 MVA and 10 MVA Power Transformer

**10.3** The bidder should not change GTP parameters of Unused Mineral Insulating oil once it offered in A/T, and Type Test Reports.

#### 11.0 Rejection :-

Apart from rejection due to failure in testing of Unused Mineral Insulating oil to meet the specified test requirements the Unused Mineral Insulating oil shall be liable for rejection on any one of the following reasons.

- i. If tests are not carried out as per clause no. 7.0 of this specification.
- iv. If Drawings are not submitted with offer as per clause no. 5.2 of this specification.
- v. If GTP parameters are not submitted as per clause no. 4.0 of this specification.
- vi. The bidder should fill up all the details in GTP parameter list, the statement such as “as per drawings enclosed”, “as per MSEDCL’s requirement” “as per IS” etc. shall be considered as details are not furnished and such offers shall liable for rejection.

#### 12.0 Quality Assurance

- 12.1** Names of the supplier for the raw material, list of standards accordingly to which the raw materials are tested, list of test normally carried out on raw materials in presence of bidder’s representatives, copies of test certificates.
- 12.2** Information and copies of test certificate as in (i) above respect of bought out accessories.
- 12.3** List of manufacturing facilities available.
- 12.4** Level of automation achieved and list of areas where manual processing still exists.
- 12.5** List of areas in manufacturing process where stage inspection are normally carried out for quality control and details of such tests and inspections.
- 12.6** List of testing equipment available with the bidder for final testing of Unused Mineral Insulating oil and test plant limitation, if any, vis-à-vis the special acceptance and routine tests specified in the relevant standards and the present specification.
- 12.7** The successful bidder shall submit the Routine Test Certificate along with documentary evidence having paid for the excise duty for the following raw materials viz Crude Petroleum, at the time of Testing.

#### 13.0 Qualifying Requirement:

- 13.1** The Tenderer must be a manufacturer of Unused Mineral Insulating oil.
- 13.2** The tenderer having ISO certificate for their manufacturing unit for Unused Mineral Insulating oil shall be given preference.
- 13.3** The bidder should have proven experience of not less than 5 years in Manufacture, supply and testing at works for offered Unused Mineral Insulating oil.
- 13.4** The bidder should have adequate in house testing facilities for conducting acceptance tests in accordance with relevant IS.

**Technical Specification of 5 MVA and 10 MVA Power Transformer**

- 13.5** Bidder should have a minimum turnover of 60% of the value of the material offered in any one financial year during the previous 3 years. However, being a commercial aspect this point may be verified by mm cell.
- 13.6** The Bidder should furnish all the relevant documentary evidence to establish the fulfillment of the above requirement.
- 13.7** The bidders not meeting the requirement at clause No. 12.1 can also participate, provided they have valid ongoing collaboration with a manufacturer who has at least 10 years experience in the manufacturing and testing of offered Unused Mineral Insulating oil, which have been in satisfactory service for a period of at least seven years. In such an event the bidder shall furnish along with the bid the documentary evidence for the same and undertaking from the bidder and collaboration accepting joint and several liability for all obligations under the contract.
- 13.8** The bidder who does not meet the above Qualifying requirement of experience (Clause No. 12.3) may be considered for a Trial Order subject to fulfilling the following requirements along with Clause Nos. 12.1 to 12.7.
- 13.9** The bidder shall have the basic infrastructure for the manufacture and supply of the Unused Mineral Insulating oil offered, like machinery, technical knowledge, capacity etc.
- 13.10** The purchaser should be satisfied with the manufacturing, supplying and financial capacity of the bidder after inspecting the bidder's works.
- 13.11** Notwithstanding anything stated above, the purchaser's decision in this regard will be final.



**Technical Specification of 5 MVA and 10 MVA Power Transformer**

**Annexure `II`  
Technical Specification for Nitrogen Injection Fire  
Protection System**



Maharashtra State Electricity Distribution Company Limited

---

TECHNICAL SPECIFICATION

FOR

NITROGEN INJECTION FIRE  
PROTECTION SYSTEM

FOR

DISTRIBUTION SYSTEM

IN

MSEDCL



**Technical Specification of 5 MVA and 10 MVA Power Transformer**

**I N D E X**

<b>Clause No.</b>	<b>Contents</b>
1	Scope
2	System Particulars
3	Service Condition
4	Applicable Standards
5	Activation of the Fire Protective System
6	General description
7	Operation
8	System components
9	Others Items
10	Technical Particulars
11	Mandatory Spares
12	Tests
13	Documentation





**Technical Specification of 5 MVA and 10 MVA Power Transformer**

**MAHARASHTRA STATE ELECTRICITY DISTRIBUTION CO. LTD.**

**TECHNICAL SPECIFICATION FOR**

**NITROGEN INJECTION FIRE**

**PROTECTION SYSTEM**

**3 Scope:-**

Nitrogen injection Fire Protection System (NIFPS) shall use nitrogen as fire quenching medium. The protective system shall prevent Transformer/Reactor's oil tank explosion and possible fire in case of internal faults. In the event of fire by external causes such as bushing fire, OLTC fires, fire from surrounding equipments etc, it shall act as fast and effective fire fighter. It shall accomplish its role as fire preventer and extinguisher without employing water and/or carbon dioxide. Fire shall be extinguished within 3 minutes (Maximum) of system activation and within 3 seconds (Maximum) of commencement of nitrogen injection.

**4 System Particulars:-**

4.1	Nominal System Voltage	:	33 kV	22 kV	11kV
4.2	Voltage variation on supply side	:	± 10 %		
4.3	Corresponding Highest System Voltage	:	36 kV	24 kV	12kV
4.4	Frequency	:	50 Hz with ± 3 % tolerance		
4.5	Transient condition	:	-20 % or + 10 % combined variation of voltage and frequency.		

**3. Service Conditions :**

**A)** The Nitrogen injection Fire Protection System to be supplied against this specification shall be suitable for satisfactory continuous operation under the following tropical conditions.

3.1	Maximum ambient temperature (Degree C)	50
3.2	Maximum temperature in shade (Degree C)	45
3.3	Minimum Temperature (Degree C)	3.5
3.4	Relative Humidity (percent)	10 to 95
3.5	Maximum Annual rain fall (mm)	1450
3.6	Maximum wind pressure (kg/sq.m)	150
3.7	Maximum altitude above mean sea level ( Meter)	1000
3.8	Isoceranin level (days per year)	50



### Technical Specification of 5 MVA and 10 MVA Power Transformer

3.9 Siesmic level (Horizontal Acceleration) 0.3 g

Moderately hot and humid tropical climate conducive to rust and fungus growth

**B)** The climatic conditions are prone to wide variations in ambient conditions and hence the equipment shall be of suitable design to work satisfactorily under these conditions.

#### 4. Applicable Standards:

The design and installation of the complete fire protection system shall comply with the latest applicable Indian Standards. Wherever Indian Standards are not available relevant British/I.E.C. codes shall be followed. The following standards /codes shall be followed in particular.

- a) Approval certificate from Loss Prevention Association.
- b) National fire Codes 1993 of National Fire protection Association (NFPA) USA.

The entire fire protection system shall be designed, erected and commissioned in accordance with the regulation of Tariff Advisory Committee (TAC). In absence of TAC regulations NFPA regulation shall be adhered to.

#### 5.0 Activation of the Fire Protective System:

Mal-functioning of fire prevention/extinguishing system could lead to interruption in power supply. The supplier shall ensure that the probability of chances of malfunctioning of the fire protective system is particularly Zero. To achieve this objective, the supplier shall [plan out his scheme of activating signals which should not be complicated to make the fire protective system inoperative in case of actual need. The system shall be provided with automatic control for fire prevention fire extinction. Besides automatic control, remote electrical push button control at control box and local manual control in the fire extinguishing cubicle shall also be provided. The following electrical signals shall be required for activating the fire protective system under prevention mode /fire extinction mode.

##### a) Auto mode :

- 1) For prevention of fire :
  - i. Differential relay operation.
  - ii. Buchholz relay paralleled with pressure relief valve or RPRR(Rapid pressure Rise Relay).
  - iii. Tripping of all circuit breakers (On HV& LV side) associated with transformer /reactor is the pre-requisite for activation of system.
- 2) For extinguishing fire :
  - i) Fire detector.
  - ii) Buchholz relay paralleled with pressure relief valve (PRV) or Sudden Pressure Relay (SPR).
  - iii) Tripping of all circuit breakers (On HV& LV side) associated with transformer /reactor is the pre-requisite for activation of system.

##### b) Manual Mode (Local/Remote) :



### Technical Specification of 5 MVA and 10 MVA Power Transformer

Tripping of all circuit breakers (On HV & LV side) associated with transformer/reactor is the pre-requisite for activation of system.

**c) Manual Mode (Mechanical) :**

Tripping of all circuit breakers (On HV & LV side) associated with transformer/reactor is the pre-requisite for activation of system.

The system shall be designed to be operated manually in case of failure of power supply to fire protection system.

#### 6.0 General description:

Nitrogen injection fire protection system should be a dedicated system for each oil filled transformer/reactor. It should have a Fire Extinguishing Cubicle (FEC) placed on a plinth at a suitable distance away from transformer/reactor. The FEC shall be connected to the top of transformer reactor oil tank for depressurization of tank and to the oil pit (capacity is approximately equal to 10 % of total volume of oil in transformer/reactor tank) from its bottom through oil pipes. The fire extinguishing cubicle should house a pressurized nitrogen cylinder(s) which is connected to the oil tank of transformer/reactor oil tank at bottom. The Transformer Conservator Isolation Valve (TCIV) is fitted between the conservator tank and Buchholz relay.

Cable connections are to be provided from signal box to the control box in the control room, from control box to the extinguishing cubicle and from TCIV to the signal box. Fire detectors placed on the top of transformer/reactor tank are to be connected in parallel to the signal box by Fire survival cables. Control box is also to be connected to relay panel in control room for receiving system activation signals.

#### 7.0 Operation:

On receipt of all activating signals, the system shall drain pre-determined volume of hot oil from the top of tank (i.e. top oil layer), through outlet valve, to reduce tank pressure by removing top oil and simultaneously injecting nitrogen gas at high pressure for stirring the oil at pre-fixed rate and thus bringing the temperature of top oil layer down. Transformer conservator isolation valve blocks the flow of oil from conservator tank in the case of tank rupture / explosion or bushing bursting. Nitrogen occupies the space created by oil drained out and acts as an insulating layer over oil in the tank and thus preventing aggravation of fire.

#### 8.0 System components :

Nitrogen injection fire protection system shall broadly consist of the following components. However, all other components which are necessary for fast reliable and effective working of the fire protective system shall be deemed to be included in the scope of the supply.

**a) Fire Extinguishing Cubicle (FEC) :**

The FEC shall be made of CRCA sheet of 3 mm (minimum) thick complete with the base frame, painted inside and outside with post office red color (shade 538 of IS -5). It shall have hinged split doors fitted with high quality tamper proof lock. The degree of protection shall be IP55. The following items shall be provided in the FEC.

- a) Nitrogen gas cylinder with regulator and falling pressure electrical contact manometer.
- b) Oil drain pipe with mechanical quick drain valve.



### Technical Specification of 5 MVA and 10 MVA Power Transformer

- c) Control equipment for draining of oil of pre-determined volume and injecting regulated volume of nitrogen gas.
  - d) Pressure monitoring switch for back-up protection for nitrogen release.
  - e) Limit switches for monitoring of the system.
  - f) Butterfly valve with flanges on the top of panel for connecting oil drain pipe and nitrogen injection pipes for transformer/reactors.
  - g) Panel lighting (CFL Type).
  - h) Oil drainpipe extension of suitable sizes for connecting pipes to oil pit.
- b) Control box :**  
Control box is to be placed in the control room for monitoring system operation, automatic control and remote operation. The following alarms, indications, switches, push buttons, audio signal etc. shall be provided.
- a) System on
  - b) TCIV open
  - c) Oil drain valve closed
  - d) Gas inlet valve closed
  - e) TCIV closed\*
  - f) Fire detector trip\*
  - g) Buchholz relay trip
  - h) Oil drain valve open\*
  - i) Extinction in progress\*
  - j) Cylinder pressure low\*
  - k) Differential relay trip
  - l) PRV / SPR trip
  - m) Transformer/reactor trip
  - n) System out of service \*
  - o) Fault in cable connecting fault fire detector
  - p) Fault in cable connecting differential relay
  - q) Fault in cable connecting Buchholz relay
  - r) Fault in cable connecting PRV / SPR
  - s) Fault in cable connecting Transformer / reactor trip.
  - t) Fault in cable connecting TCIV
  - u) Auto/ Manual/ Off
  - v) Extinction release on/off
  - w) Lamp test
  - x) Visual/ Audio alarm\*
  - y) Visual/ Audio alarm for DC supply fall\*
- \* Suitable provision shall be made in the control box , for monitoring of the system from remote substation using the substation automation system.
- c) Transformer Conservator Isolation Valve :**  
Transformer conservator isolation valve(TCIV) to be fitted in the conservator pipe line, between conservator and Buchholz relay which shall operate for isolating the conservator during abnormal flow of oil due to rupture / explosion of tank or bursting of bushing. The valve shall not isolate conservator during normal flow of oil during



### Technical Specification of 5 MVA and 10 MVA Power Transformer

- filtration or filling or refilling, locking plates to be provided with handle for pad locking. It shall have proximity switch for remote alarm, indication with visual position indicator. The TCIV should be of the best quality as malfunctioning of TCIV could lead to serious consequence. The closing of TCIV means stoppage of breathing of transformer / reactor. Locking plates shall be provided for pad locking.
- d) Fire detectors :**  
The system shall be complete with adequate number of fire detectors (quartz bulb) fitted on the top cover of the transformer / reactor oil tank.
- e) Signal box :**  
It shall be mounted away from transformer / reactor main tank, preferably near the transformer marshaling box, for terminating cable connections from TCIV & fire detectors and for further connection to the control box. The degree of protection shall be IP55.
- f) Cables :**  
Fire survival cables (capable to withstand 750 deg. C) of 4 core x 1.5 sq. mm size for connection of fire detectors in parallel shall be used. The fire survival cable shall conform to BS 7629-1, BS 8434-1, BS 7629-1 and BS 5839-1, BS EN 50267-2-1 or relevant Indian standards.  
Fire Retardant Low Smoke( FRLS ) cable of 12 core x 1.5 sq. mm size shall be used for connection of signal box / marshaling box near transformer / reactor and FEC mounted near transformer / reactor with control box mounted in control room.  
Fire Retardant Low Smoke(FRLS) cable of 4 core x 1.5 sq. mm size shall be used for connection between control box to DC and AC supply source, fire extinguishing cubicle to AC supply source, signal box / marshaling to transformer conservator isolation valve connection on transformer.
- g) Pipes :**  
Pipes complete with connections, flanges, bends and tees etc. shall be supplied along with the system. Pipes and welding shall be sufficiently passivated and environment protected.
- 9.0 Others Items :**
- a)** Oil drain and nitrogen injection openings with gate valves on transformer / reactor tank at suitable locations.
  - b)** Flanges with dummy piece in conservator pipe between Buchholz relay and conservator tank for fixing TCIV.
  - c)** Fire detector brackets on transformer / reactor tank top cover.
  - d)** Spare potential free contacts for activating the system i.e differential relay, Buchholz relay, Pressure relief device /RPRR, circuit breaker of transformer / reactor.
  - e)** Pipe connections between transformer / reactor and FEC and between FEC and **oil pit** required for collection top oil.
  - f)** Cabling for fire detectors mounted on transformer / reactor top cover.
  - g)** Inter cabling between signal box , control box and Fire Extinguishing Cubicle(FEC).  
All external cables from / to the system i.e signal box to control box and control box to FEC shall be provided by the purchaser. All internal cables within the system i.e



### Technical Specification of 5 MVA and 10 MVA Power Transformer

between detectors /signal box /marshaling box/FEC/TCIV shall be in the scope of NIFPS supplier .

- h) Butterfly valves / Gate valves on oil drain pipe and nitrogen injection pipe which should be able to withstand full vacuum.
- i) Supports valves, signal box etc. which are to be painted with enameled paint.

#### 10.0 Technical Particulars :

Sr. No.	Particulars	Details
1.	Fire extinction period from commencement of Nitrogen Injection	30Sec(Max)
2.	Fire extinction period from the moment of system activation.	3 minutes.(Max)
3.	Fire detectors heat sensing temperature	Vendor to specify
4.	Heat sensing area per detector	Vendor to specify
5.	Transformer conservator isolation valve setting-min	Vendor to specify
6.	Capacity of nitrogen cylinder	Vendor to specify
7.	Power supply	
	a) For control	30/110 DC, variation -15%,+10 %
	b) For service/lighting	250 V AC , Variation +/- 10 %

The doors, removable covers and panels shall be gasketed all round with neoprene gaskets.

#### 11.0 Mandatory Spares :

- a) Cylinder filled with Nitrogen of required capacity per substation :- 1.No.
- b) Fire detectors per transformer :- 3 No.
- c) Regulator assembly per substation :- 1 No.

#### 12.0 Tests :

Reports of all type tests conducted as per relevant IS/IEC standards in respect of various bought out items including test reports for degree of protection for FEC/control box/signal box shall be submitted by the supplier.

The supplier should demonstrate the functional test associated with the following

- a) Fire extinguishing cubicle, control box.
- b) Fire detector.
- c) Transformer Conservator Isolation Valve.

The performance test of the complete system shall be carried out after erection of the system with transformer at site.

#### 13.0 Documentation:

- a) To be submitted along with offer :
  - General outline of the system.
  - Detailed write-up on operation of the offered protection system including maintenance and testing aspects / schedules.



**Technical Specification of 5 MVA and 10 MVA Power Transformer**

Technical Data Particulars (GTP).

Data regarding previous supplies , date of commissioning, performance feedback etc.

**b)** To be submitted after award of contract :

Detailed dimensional layout drawing of the system with complete bill of materials, clearances from ground and other live points, details of detectors ,equipment layout, drawings ,detailed drawings pertaining to signal box, control box, FEC equipment, wiring and schemes,4 sets of testing, commissioning ,Operation and Maintenance manual along with soft copies (in CDs) shall be submitted by supplier.



Technical Specification of 5 MVA and 10 MVA Power Transformer

<p><b>NAME OF MANUFACTURE</b> ADDRESS</p>		<p><b>VECTOR GROUP DYN-11</b></p>	
<p>COOLING MATING NO. LINES VOLTAGE</p>	<p>NO. PHASES H.V. VOLT L.V. VOLT</p>	<p>NATIONAL SERIAL NO. NO. ESTABLISHED REGISTRATION FABRIK</p>	<p>NO. OF TAPERS H.V. SA NO. SA TYPE DIN-31</p>
<p>FULL LOAD CURRENT SERIAL NO. LEVEL TYP./A.M. MAGNET TURNS WIND. TEMP. RISE ON HTL. TEMP. RISE ON IMPROVED WINDING</p>	<p>H.V. AMPERES L.V. AMPERES</p>	<p>VECTOR GROUP OL QUANTITY (SINGLE/DOUBLE DECK) CORE AND SHIELDING TAPES AND RETURN OIL DIELECT. QUANTITY VENTIL. SYSTEM INSULIN &amp; SERIAL OF PAPEL</p>	<p>NO. OF TAPERS H.V. SA NO. SA TYPE DIN-31</p>
<p>CUSTOMER :- MAHARASHTRA STATE ELECTRICITY DISTRIBUTION CO. LTD. P.L. NO. 1 -</p>			
<p>PROBABLE SECTION CONNECTION O.L.T.C.</p>		<p>SEE SPOTCH CONNECTION O.L.T.C.</p>	
<p>NO. OF TAPERS H.V. VOLT L.V. VOLT</p>		<p>H.V. AMPERES L.V. AMPERES</p>	
<p>MATERIAL OF WINDINGS : COPPER</p>			
<p>PROPERTY OF : M.S.E.D.CO. LTD.</p>			

<p><b>NAME OF MANUFACTURE</b></p>		<p><b>RATING &amp; TERMINAL MARKING PLATE</b> FOR --- KVA --- / --- KV POWER TRANSFORMER</p>	
<p>NO. OF TAPERS H.V. VOLT L.V. VOLT</p>	<p>H.V. AMPERES L.V. AMPERES</p>	<p>NO. OF TAPERS H.V. SA NO. SA TYPE DIN-31</p>	<p>NO. OF TAPERS H.V. SA NO. SA TYPE DIN-31</p>

**NOTE:-**

1. ( ) ACTUAL DIMENSIONS SHALL BE MARKED AT THE TIME OF DELIVERY.
2. DIMENSIONS OF WINDING ROOM - X - X - SEE THE INTERNAL.

ALL DIMENSIONS ARE IN MM.

MAHARASHTRA STATE ELECTRICITY DISTRIBUTION CO. LTD.

ELECTRICITY DISTRIBUTION

THIS IS AN INDICATIVE DRAWING











Technical Specification of 5 MVA and 10 MVA Power Transformer

Sl. No.	Description	As Specified	As Offered	Sl. No.	Description	As Specified		As Offered Equipment	
						H.V. O.L.	L.V. O.L.	H.V.	L.V.
01	PRIMARY VOLTAGE (KV)	AS SPECIFIED	AS OFFERED	12	WINDING	AS SPECIFIED	AS OFFERED		
02	SECONDARY VOLTAGE (KV)	AS SPECIFIED	AS OFFERED	13	NO. OF TURNS	AS SPECIFIED	AS OFFERED		
03	RATING (KVA)	AS SPECIFIED	AS OFFERED	14	INSULATION MATERIAL	AS SPECIFIED	AS OFFERED		
04	VECTOR GROUP	DM11	DM11	15	QUANTITY DENSITY $A/mm^2$	AS SPECIFIED	AS OFFERED		
05	CONNECTION TO	IS-2025	IS-2025	16	NO. OF TURNS	AS SPECIFIED	AS OFFERED		
06	PER. NORMAL VOLTAGE FLUCTUATION %	AS SPECIFIED	AS OFFERED	17	INSIDE DIMENSION mm	AS SPECIFIED	AS OFFERED		
07	TEMP. OF TOP OIL (MAX.) <sup>o</sup> C	AS SPECIFIED	AS OFFERED	18	ACTUAL LENGTH mm (SHALLING)	AS SPECIFIED	AS OFFERED		
08	TEMP. OF WINDING (MAX.) <sup>o</sup> C	AS SPECIFIED	AS OFFERED	19	NO. OF COILS PER PHASE	AS SPECIFIED	AS OFFERED		
09	COIL DETAILS	AS SPECIFIED	AS OFFERED	20	RESISTANCE PER PHASE AT 20 <sup>o</sup> C	AS SPECIFIED	AS OFFERED		
10	COIL MATERIAL	AS SPECIFIED	AS OFFERED	21	PER. LOSS	AS SPECIFIED	AS OFFERED		
11	PROVIDED SOURCE OF COIL MATERIAL	AS SPECIFIED	AS OFFERED	22	NO. LOAD LOSSES WIND	AS SPECIFIED	AS OFFERED		
12	GAP OF LAMINATION	AS SPECIFIED	AS OFFERED	23	FULL LOAD LOSSES AT 75 <sup>o</sup> C	AS SPECIFIED	AS OFFERED		
13	FLUX DENSITY	1.55 MAX.	AS SPECIFIED	24	TANK	AS SPECIFIED	AS OFFERED		
14	NO. OF STRIPS	AS SPECIFIED	AS OFFERED	25	SIDE WALL THICKNESS mm	AS SPECIFIED	AS OFFERED		
15	NO. OF STRIPS	AS SPECIFIED	AS OFFERED	26	TOP & BOTTOM PLATE THICKNESS mm	AS SPECIFIED	AS OFFERED		
16	COIL DIMENSION	AS SPECIFIED	AS OFFERED	27	COIL USED	AS SPECIFIED	AS OFFERED		
				28	NAME OF MANUFACTURE	AS SPECIFIED	AS OFFERED		
				29	GAP/CHG. VOLUME (LITERS)	AS SPECIFIED	AS OFFERED		
				30	IN TANK OIL IN CONSERVATOR	AS SPECIFIED	AS OFFERED		
				31	TOTAL	AS SPECIFIED	AS OFFERED		
				32	CONDUCTOR	AS SPECIFIED	AS OFFERED		
				33	NAME	AS SPECIFIED	AS OFFERED		
				34	CAPACITY	AS SPECIFIED	AS OFFERED		
				35	DETAILED HEAT DISSIPATION CALCULATION	AS SPECIFIED	AS OFFERED		

MAHARASHTRA

NUMBAI.

ELECTRICITY

DIS

NOTION

COMPLIANCE 1 - MAHARASHTRA STATE ELECTRICITY DISTRIBUTION CO. LTD.,  
P.O. NO. 1 -

NAME OF MANUFACTURE

TECHNICAL DETAILS OF  
KVA, KV POWER TRANSFORMER

SCALE: 1:10

DATE

BY

ALL DIMENSIONS ARE IN MM.















Technical Specification of 5 MVA and 10 MVA Power Transformer

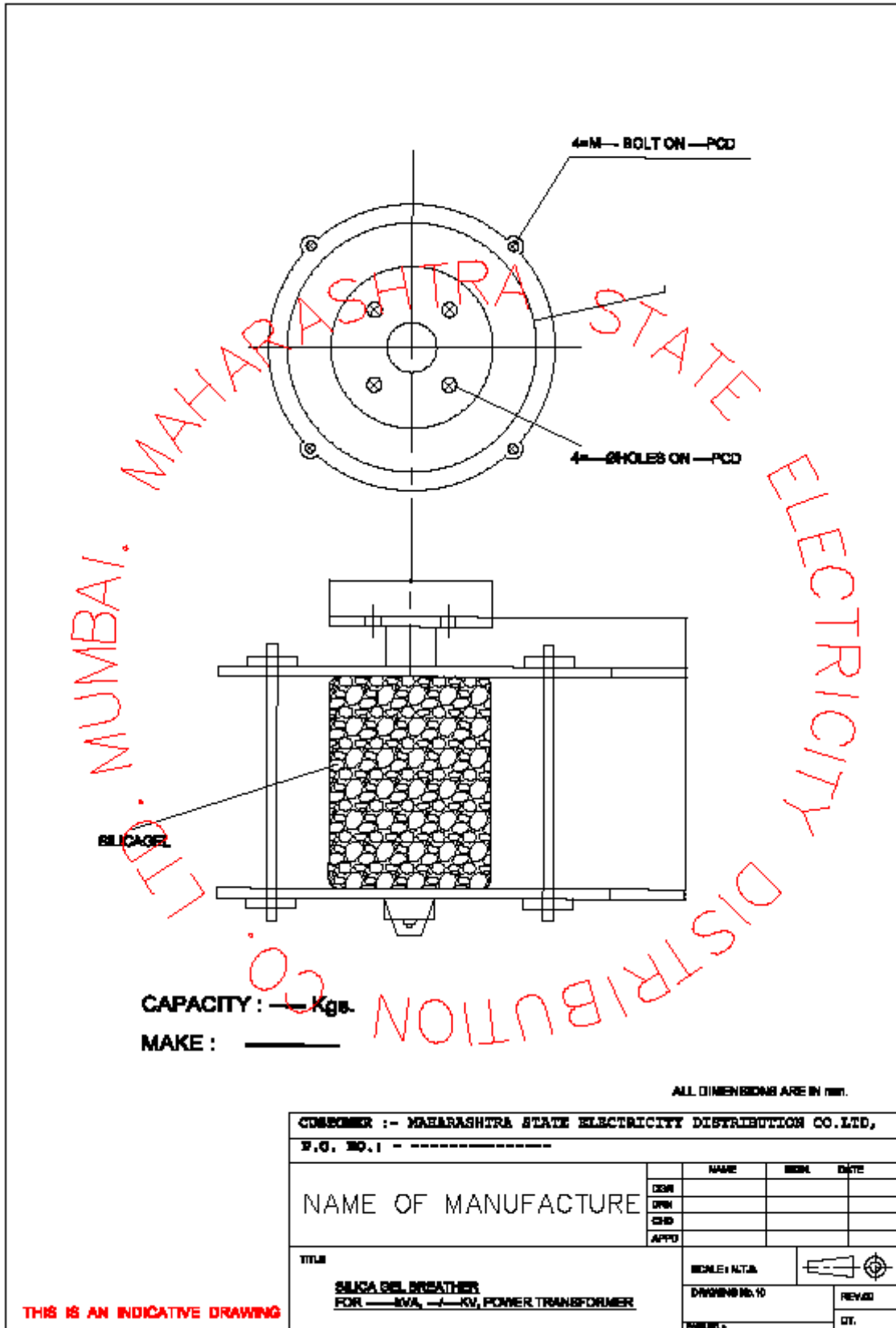



Technical Specification of 5 MVA and 10 MVA Power Transformer

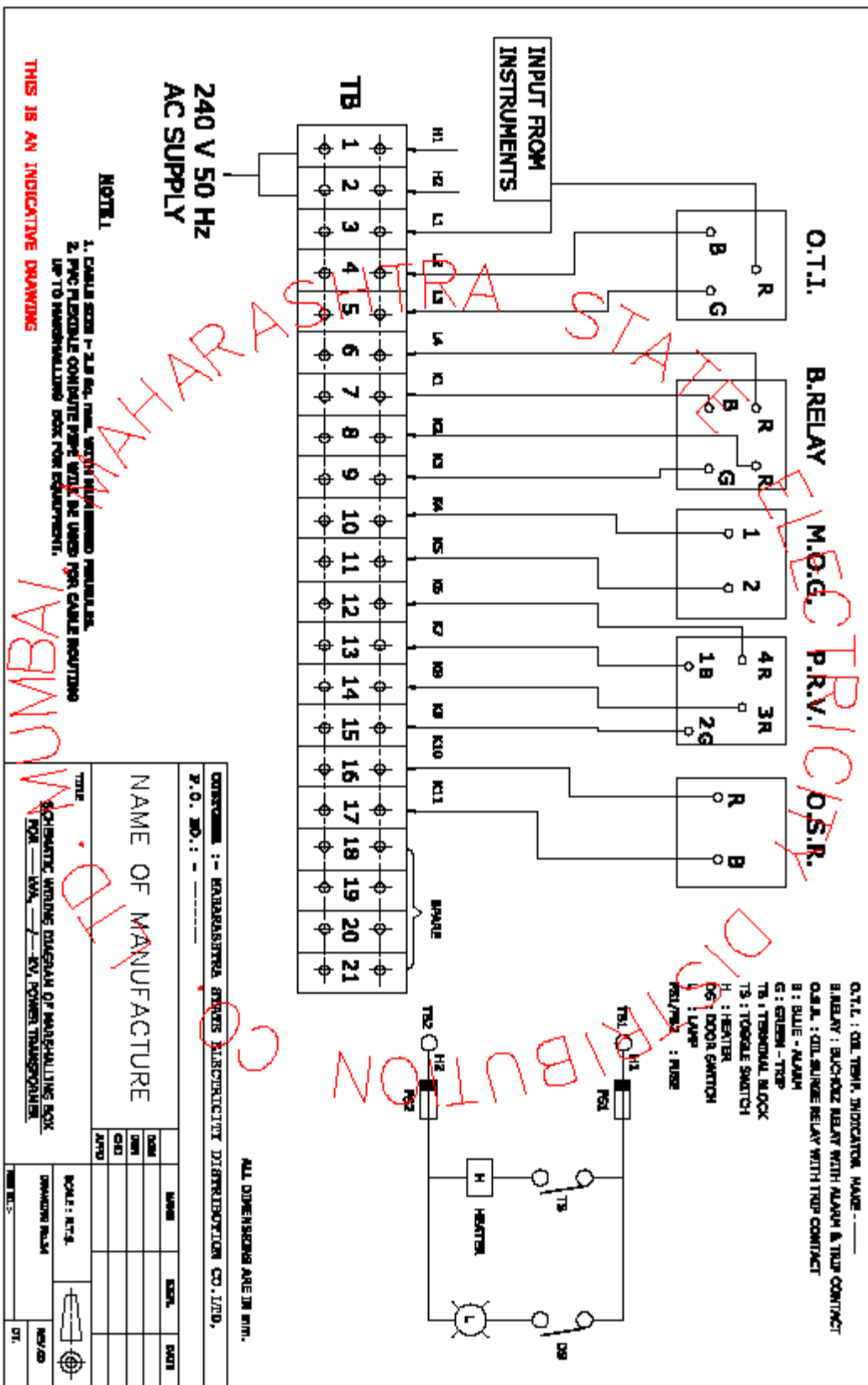





Technical Specification of 5 MVA and 10 MVA Power Transformer

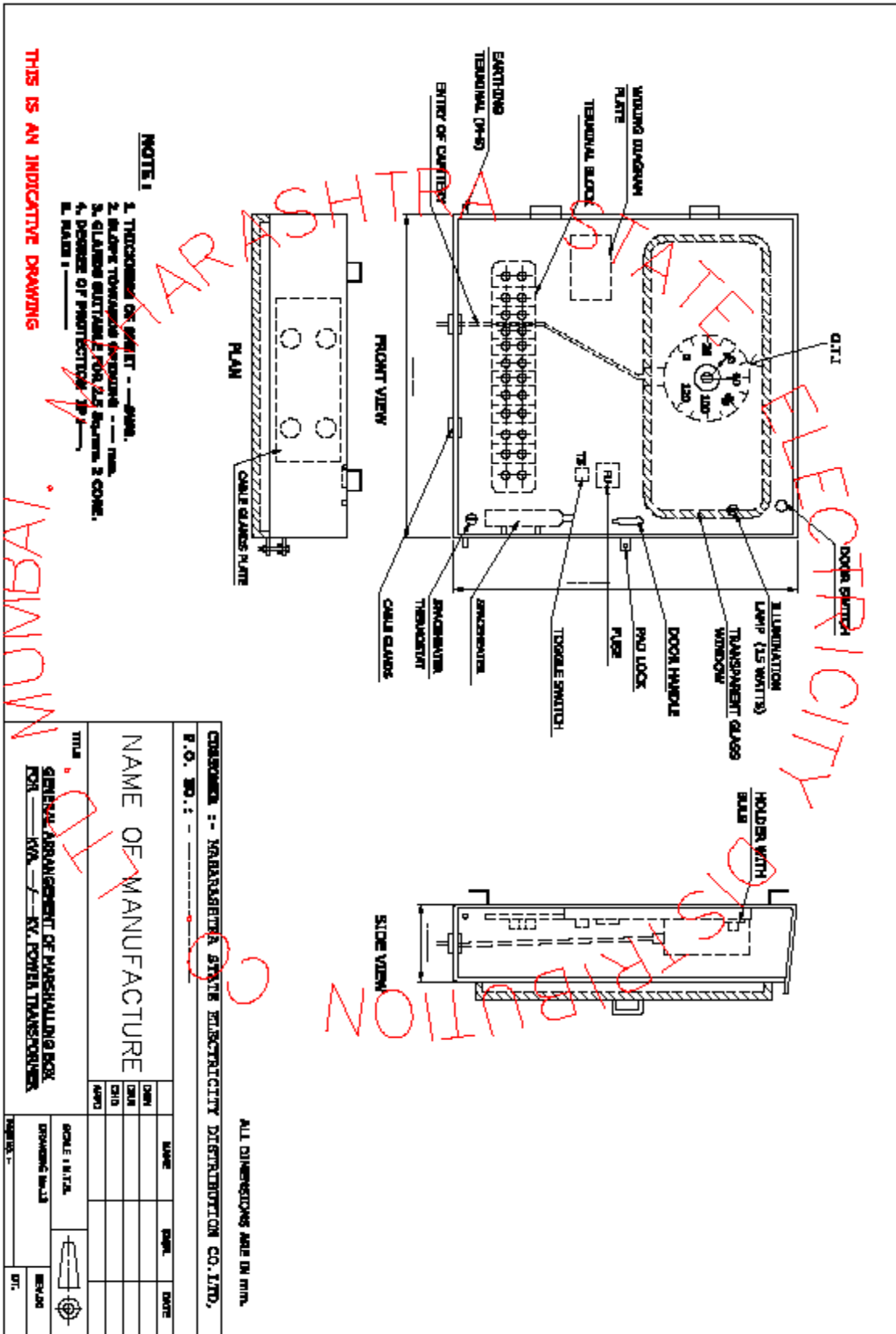



Technical Specification of 5 MVA and 10 MVA Power Transformer

# GTR ON LOAD TAPCHANGER

LICENCE: ENGLISH ELECTRIC, ENGLAND.

TYPE  S.N.  YEAR

CTR O.A.N.C.  CUSTOMER W.D.N.C.

MOTOR  V  50 HZ CONTROL  V  50 HZ

SERVICE VOLTAGE  KV NORMAL WORKING CURRENT  A

MAX. RATED THROUGH CURRENT  A

PHASES  3 FREQUENCY  50 HZ STEPS  STEP VOLTAGE  V

WEIGHTS/VOLUME

TAPCHANGER WITHOUT OIL  Kg

OIL  Kg  LITRES TOTAL  Kg

THIS TAPCHANGER IS SUITABLE FOR DIRECTION OF POWERFLOW TO THE EXTENT SHOWN BELOW.

HV TO LV  % LV TO HV  %

MAKERS: **EEL** MANUFACTURING INDUSTRIES LIMITED. IS:8468  
POONA-411014 INDIA.

CONSUMER :- MAHARASHTRA STATE ELECTRICITY DISTRIBUTION CO. LTD.

P.O. NO. :-

NAME OF MANUFACTURE

DATE	NAME	SCALE	DATE

TITLE: QLTG RATING PLATE(GTR MAKE) FOR -----KV, POWER TRANSFORMERS

SCALE: 1:17.5

DRAWING No. 13

REVISED

DT.

THIS IS AN INDICATIVE DRAWING

MUMBAI. MAHARASHTRA STATE ELECTRICITY DISTRIBUTION CO.





Technical Specification of 5 MVA and 10 MVA Power Transformer

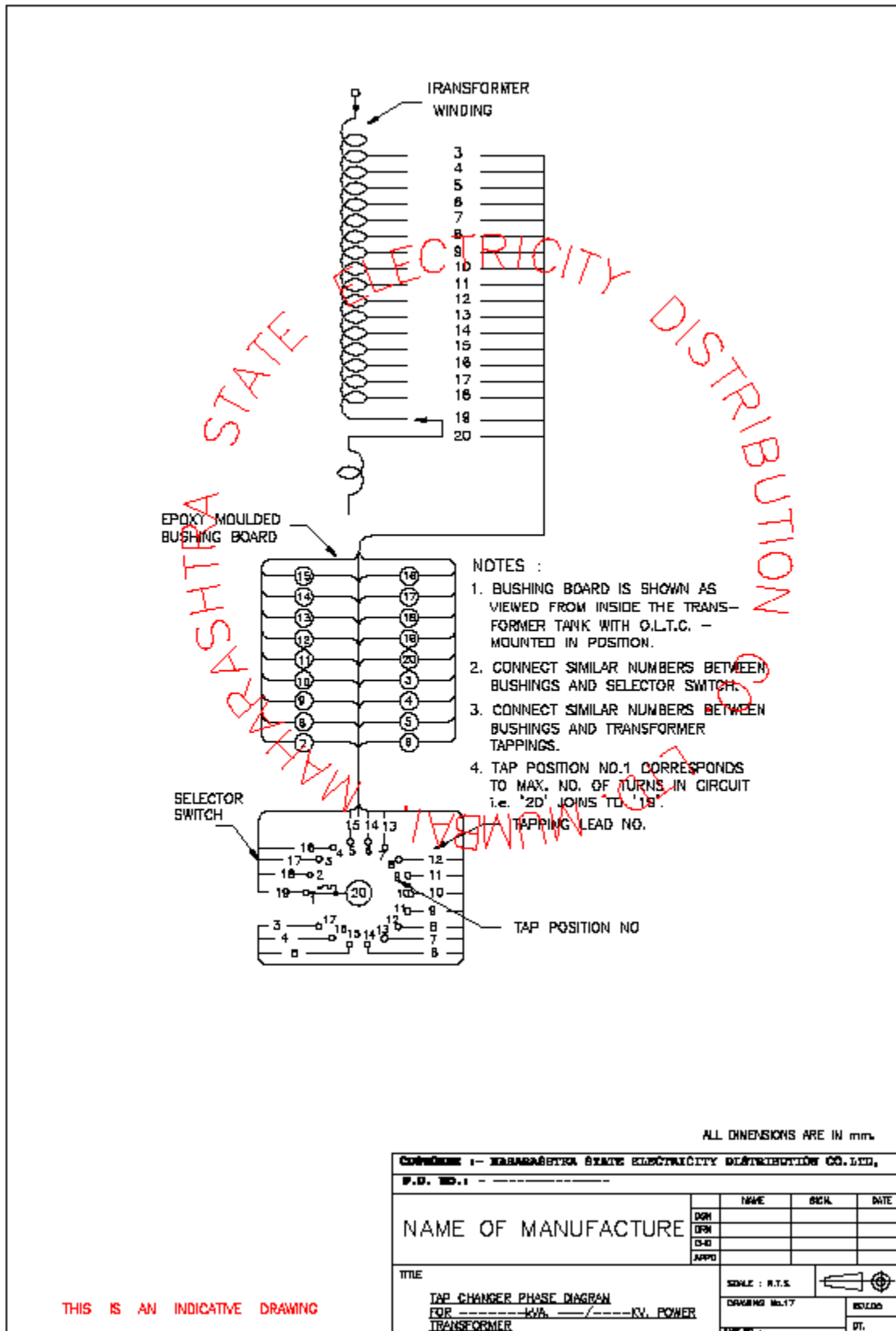







Technical Specification of 5 MVA and 10 MVA Power Transformer

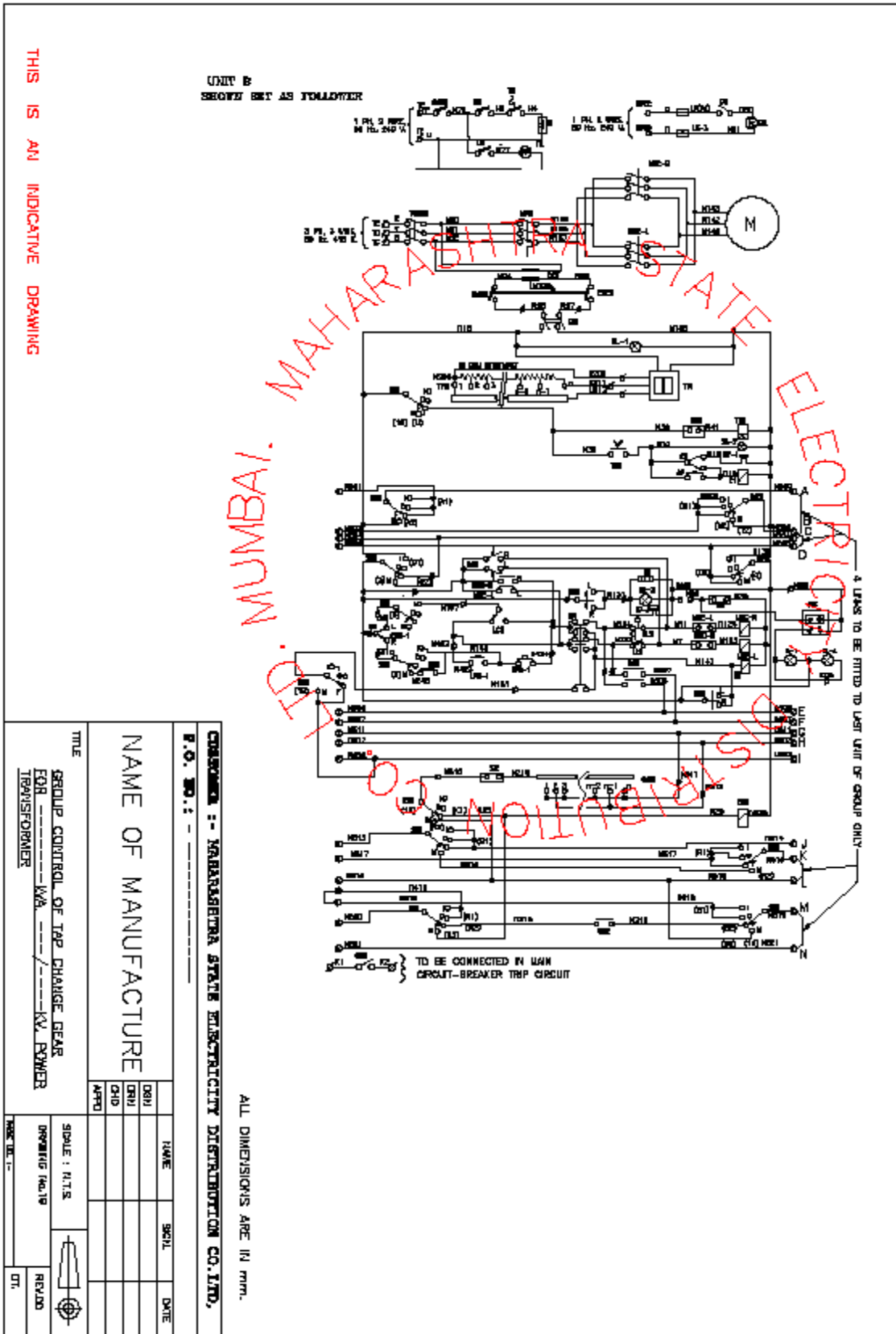

THIS IS AN INDICATIVE DRAWING



Technical Specification of 5 MVA and 10 MVA Power Transformer

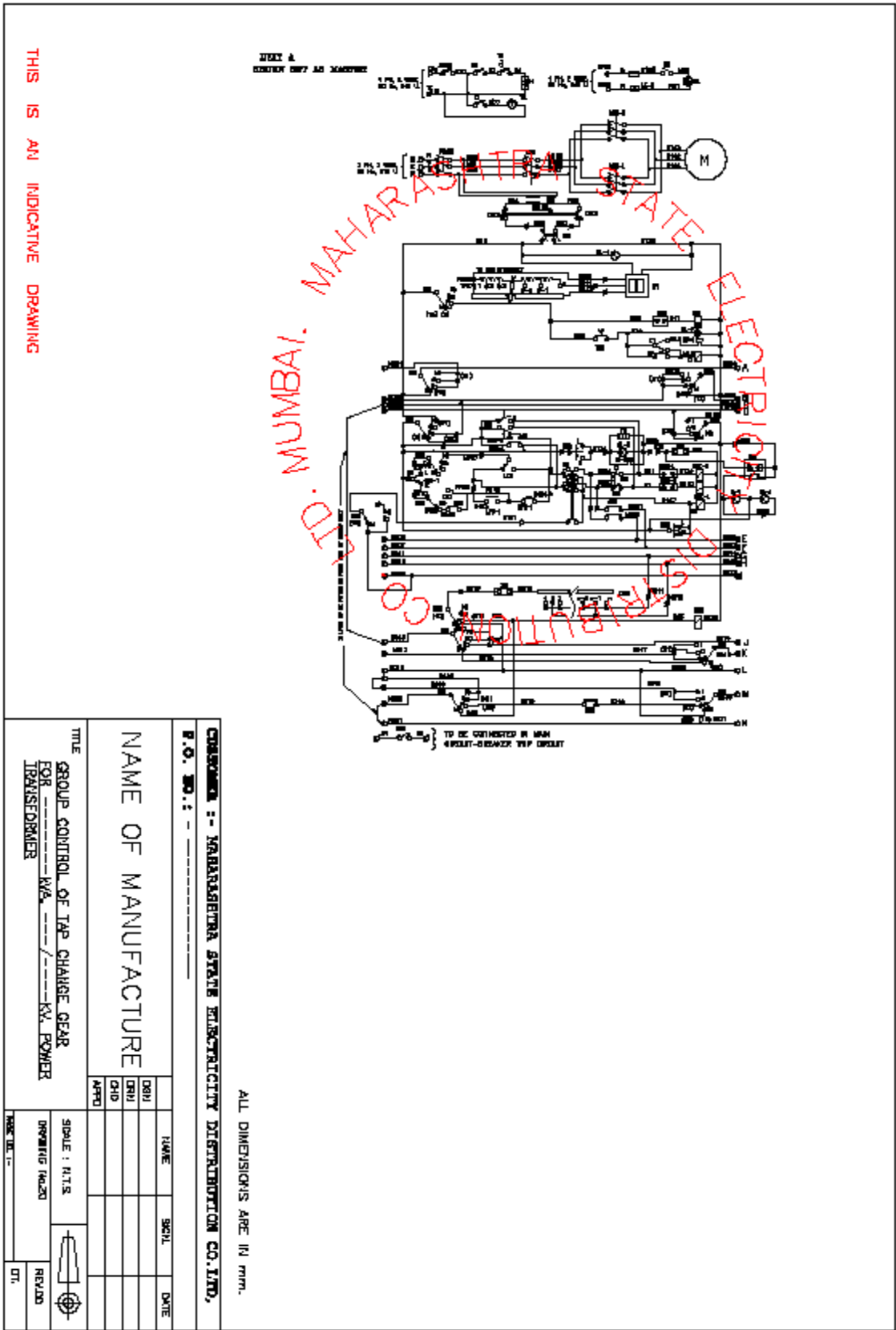



Technical Specification of 5 MVA and 10 MVA Power Transformer

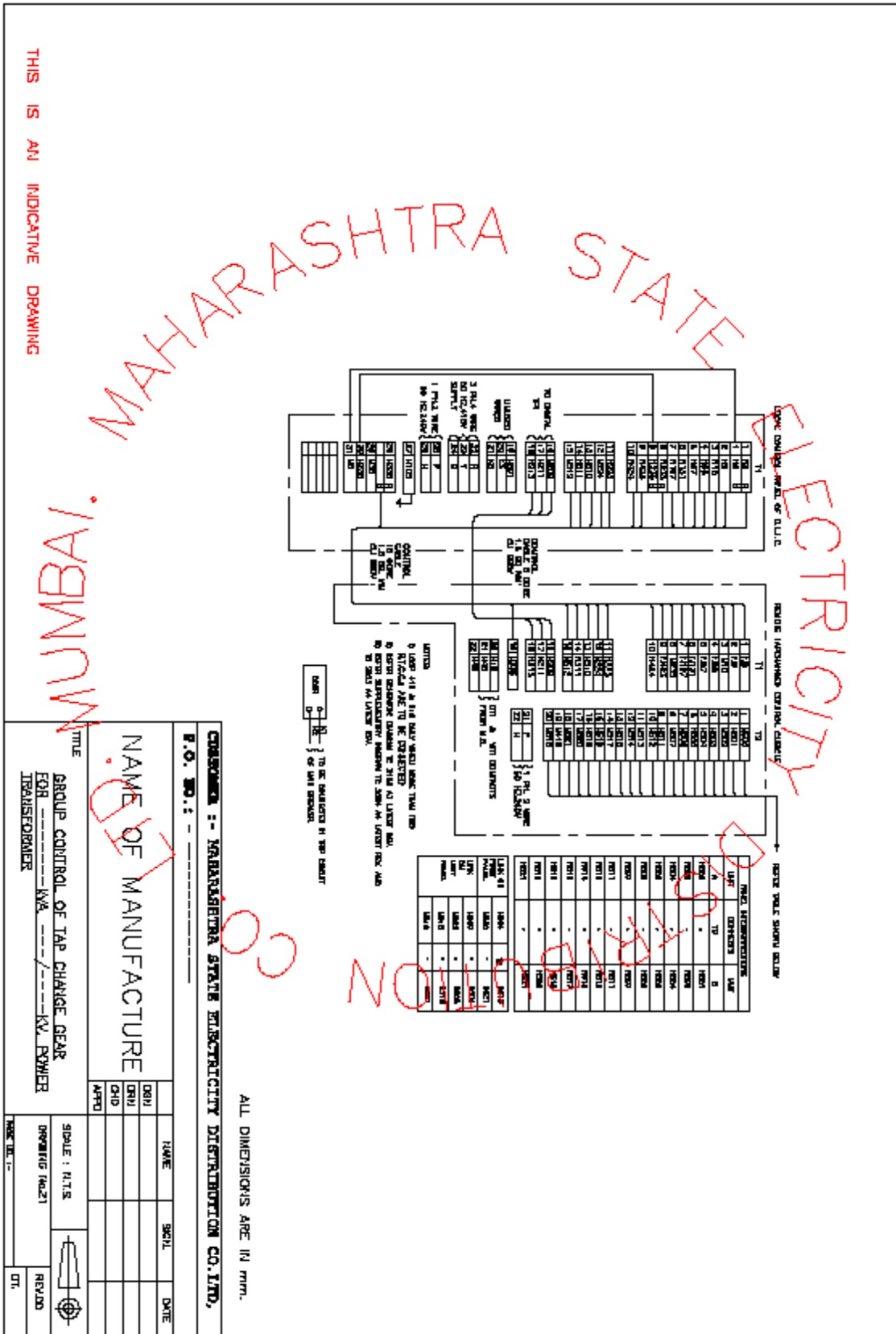

THIS IS AN INDICATIVE DRAWING

MUMBAI. MAHARASHTRA STATE ELECTRICITY DISTRIBUTION

**CONSUMER :- MAHARASHTRA STATE ELECTRICITY DISTRIBUTION CO. LTD.**

**P. O. NO. :-**

**NAME OF MANUFACTURE**

**GROUP CONTROL OF TAP CHANGE GEAR FOR ---KV. ---KV. POWER TRANSFORMER**

**SCALE : 1/12.5**

**DRAWING NO. DT.**

ALL DIMENSIONS ARE IN mm.





Technical Specification of 5 MVA and 10 MVA Power Transformer

THIS IS AN INDICATIVE DRAWING

33	GRABER		
32	ISALATION		
31	TRANSFORMER OIL		
30	COPPER		
29	CORE		
28	AIR RELEASE PLUG		
27	OIL LEVEL GAUGE INDICATING 3 POS. OF OIL MARKED		
26	CONSERVATOR DRAIN VALVE		
25	L.V. OUTDOOR BUSHING 12 KV 630A		
24	H.V. OUTDOOR BUSHING 28 KV 630A		
23	POCKET FOR DRY		
22	DUAL TYPE OIL MATH. A/T CONTACT		
21	WASHING BOX		
20	THERMOMETRIC FOOTLET		
19	INSPECTION HOLE WITH COVER		
18	PRESSURE RELIEF VALVE		
17	SHUT OFF VALVE BTRM. CONV. & TOP COVER		
16	DOUBLE FLOAT BUSHHOLD RELAY WITH A/T CONTACT		
15	RAIDATOR SWIK WITH TOP & BOTTOM SHUT OFF VALVE		
14	CR. LOAD TAP CHANGING GEAR WITH OIL SUIECE RELAY		
13	EXPLSION YELT WITH EQUALIZER PIPE		
12	DEHYDRATING SLAGGER BRICKNER		
11	OIL CONSERVATOR WITH OIL FILLING HOLE & LIFTING LUGS		
10	COVER JINING LUG		
9	JACING LUG		
8	HALLING EYES		
7	LIFTING LUG		
6	WAVE BATHING & DRYGEM PLATE		
5	OIL SAMPUNG VALVE WITH FLANGE (TOP & BOTTOM)		
4	OIL FILTER VALVE WITH FLANGE (TOP & BOTTOM)		
3	OIL DRAIN VALVE WITH FLANGE		
2	UNDER BASE CHAIRRED WITH B-ONE FLANGED ROLLERS		
1	EARTHING TERMINALS WITH DRIMPING LUG		
	PT10A		

ELECTRICITY DISTRIBUTION CO.

MAHABAI.

ALL DIMENSIONS ARE IN MM.

CONSUMER :- MAHARASHTRA STATE ELECTRICITY DISTRIBUTION CO. LTD,  
 P. O. NO. :-

NAME OF MANUFACTURE

SCALE: 1:12.5

DATE

BY

DT.



## Technical Specification Cont

Item	Technical Specification
33 11KV, 10MVA POWER TRANSFORMER(85000804273)	Refer To The Following Item Specification: 33 11 KV, 5 MVA POWER TRANSFORMER(85000803713)



## 33 11KV, 10MVA POWER TRANSFORMER

GTP Order Sequence	GTP Parameters	Date Type
1	Brand Name & Manufacturer's Name	TEXT
2	Place of manufacturer	TEXT
3	Type (Indoor/Outdoor)	TEXT
4	Normal KVA output	TEXT
5	4.a Continuous max. KVA rating as per IS 2026/1977 amended to date corresponding to a temp. rise of 50 deg. C (in oil) under max. Ambient temp. of 50 deg. C	TEXT
6	4.b Continuous max. KVA rating at site corresponding to 50 deg. C temp rise in oil with max. ambient temp of 50 deg. C	TEXT
7	Maximum Temperature rise for top oil over an ambient temperature of 50 0C should be 50 0C maximum (measured by thermometer in accordance with IS 2026 or relevant International Standard).	TEXT
8	Maximum Temperature rise for winding over an ambient temperature of 50 0C should be 55 0C maximum (measured by resistance method in accordance with IS 2026 or relevant International Standard).	TEXT
9	No. of phases	NUMERIC
10	Voltage between phases (HV Side) at normal tap 5, in volts	TEXT
11	Voltage between phases (LV Side) at normal tap 5, in volts	TEXT
12	Connections on HV	TEXT
13	Connections on LV	TEXT
14	Vector group	TEXT
15	Frequency	TEXT
16	Tapping - Range	TEXT
17	Tapping - No of steps	TEXT
18	Method of cooling	TEXT
19	Max. core losses at normal voltage & normal frequency-KW (without IS Tol.)	TEXT
20	Max. losses at max. voltage or at 110% voltage at normal frequency - KW (without IS Tol.)	TEXT
21	Max. load losses at normal full load current- KW at 75 deg. C	TEXT
22	Resistance voltage drop of full load at normal tap at 75 deg. C in volts	TEXT
23	% Reactance drop on full load at normal tap at 75 deg. C	TEXT
24	% Impedance Voltage drop on full load at normal tap at 75 deg. C	TEXT
25	Current Density - Primary winding Amps per sq.mm.(Main & Tap)	TEXT
26	Current Density - Secondary winding Amps per sq.mm.	TEXT
27	Winding Resistance per phase in ohms at 75 deg..C for HV Winding (Main & Tap)	TEXT

28	Winding Resistance per phase in ohms at 75 deg..C for LV Winding	TEXT
29	No. of turns - HV Winding ( Main & Tap )	TEXT
30	No. of turns - LV Winding	TEXT
31	Core	TEXT
32	Grade of laminations & type of core	TEXT
33	Core material used & thickness	TEXT
34	Type of core construction	TEXT
35	Winding insulation details	TEXT
37	Type of insulation of winding - HV Side	TEXT
38	Type of insulation of winding - LV Side	TEXT
39	Class of insulation winding - HV Side	TEXT
40	Class of insulation winding - LV Side	TEXT
41	Guaranteed efficiency at standard reference temp. of 75 deg. C & normal voltage ratio in % - on 100% load at 1 p. f. Mfg. to give	TEXT
42	Guaranteed efficiency at standard reference temp. of 75 deg. C & normal voltage ratio in % - on 75% load at 1 p. f.	TEXT
43	Guaranteed efficiency at standard reference temp. of 75 deg. C & normal voltage ratio in % - on 50% load at 1 p. f.	TEXT
44	Guaranteed efficiency at standard reference temp. of 75 deg. C & normal voltage ratio in % - on 100% load at 0.8 lag p. f.	TEXT
45	Guaranteed efficiency at standard reference temp. of 75 deg. C & normal voltage ratio in % - on 75% load at 0.8 lag p. f.	TEXT
46	Regulation on full load at 75 deg. C & normal voltage ratio in % at 1 p.f.	TEXT
47	Regulation on full load at 75 deg. C & normal voltage ratio in %at 0.8 p.f.(lag)	TEXT
48	Min. Clearance to earth of primary winding in mm	TEXT
49	Min. Clearance to earth of secondary winding in mm	TEXT
50	Impulse withstand voltage on high tension winding (stating nature of impulse ) KV	TEXT
51	Type of tank	TEXT
52	Total radiating surface sq.mt. (i.e. radiators, tank-tank body & top cover ). Furnish the calculations	TEXT
53	Heat generated by the transformer for the given losses in joules, furnish the calculations	TEXT
54	Noise level at a distance of 1 m	TEXT
55	Weight of core	TEXT
56	Weight of copper in primary (HV).(Main & Tap ) per phase	TEXT
57	Weight of copper in secondary (LV) per phase	TEXT
58	Weight of core coil assembly	TEXT
59	Weight of lift for inspection (top cover)	TEXT
60	Weight of conservator with oil	TEXT
61	Weight of conservator without oil	TEXT

62	Weight of tank with radiators	TEXT
63	Weight of tank with oil & Term. Boxes (HV/LV)	TEXT
64	Weight of one radiator with oil	TEXT
65	Weight of one radiator without oil	TEXT
66	Weight of OLTC with oil	TEXT
67	Weight of OLTC without oil	TEXT
68	Weight of HV Cable Box	TEXT
69	Weight of LV Cable Box	TEXT
70	Weight of Oil only in Tank	TEXT
71	Weight of Oil only In OLTC	TEXT
72	Weight of Oil only In Conservator	TEXT
73	Weight of transformer complete with oil & all accessories	TEXT
74	Quantity of Oil Liters - In tank	TEXT
75	Quantity of Oil Liters - In conservator	TEXT
76	Quantity of Oil Liters - In OLTC	TEXT
77	Overall dimensions when installed ( with accessories fitted) - Length (mm) 5200 mm	TEXT
78	Overall dimensions when installed ( with accessories fitted) - Width (mm) 4200 mm	TEXT
79	Overall dimensions when installed ( with accessories fitted) - Height (mm) 5800 mm	TEXT
80	Transport dimensions - Length (mm)	TEXT
81	Transport dimensions - width(mm)	TEXT
82	Transport dimensions - height (mm)	TEXT
83	Head room necessary to allow removal of core in meters	TEXT
84	Available clear space of 1 m ( considering the size of transformer bay & overall dimensions of transformer ) req. all round for adequate ventilation is sufficient	TEXT
85	OLTC	TEXT
86	Details of OLTC Gear	TEXT
87	OLTC - MVA Rating	TEXT
88	OLTC - Current Rating	TEXT
89	OLTC Voltage Ratio	TEXT
90	OLTC Type of connection	TEXT
91	Particulars of OLTC gear offered make & type of the OLTC. Performance certificates attached (Yes/No)	TEXT
92	Type & Routine test certificates from CPRI attached (Yes/No)	TEXT
93	Overall dimensions	TEXT
94	Step voltage	TEXT
95	Max. Working current	TEXT

96	Value & Wattage of transition resistor	TEXT
97	Type test certificates in respect of 5/10 MVA transformer with voltage class 33 KV and 22 KV	TEXT
98	List of supplier of raw materials like copper, core, transformer oil, insulating materials etc. Details about quality control methods adopted to assess the quality of raw/ finished material	TEXT
99	List of plant machinery & testing equipments indicating their ratings & make, for carrying out all routine/acceptance tests & certain type tests such as Heat Run at full load, Impulse test , Noise level measurement etc.	TEXT
100	Drawings:	TEXT
101	Dimensional drawings of the transformer with radiators, conservators etc. fitted. General arrangement drawing one sheet comprising of plan, elevation, side view of the complete transformer & other details like legends, untanking height, clearance etc. also all above drawings in separate sheets	TEXT
102	Transport outline of the transformer including transport weight	TEXT
103	Rating & Diagram plate. Connection diagram of the transformer winding showing the position of tapping etc.	TEXT
104	Bushings (primary & secondary) drawings.	TEXT
105	Cable box assembly (LV) drawing along with support arrangement	TEXT
106	Cable box assembly (HV) drawing alongwith support arrangement	TEXT
107	Dimensional drawings of the OLTC gear (internal details).	TEXT
108	Schematic diagram of the OLTC arrangement for Transformer operating independently.	TEXT

33 11 KV, 5 MVA POWER TRANSFORMER

GTP Order Sequence	GTP Parameters	Date Type
1	Brand Name & Manufacturer's Name	TEXT
2	Place of manufacturer	TEXT
3	Type (Indoor/Outdoor)	TEXT
4	Normal KVA output	TEXT
5	4.a Continuous max. KVA rating as per IS 2026/1977 amended to date corresponding to a temp. rise of 50 deg. C (in oil) under max. Ambient temp. of 50 deg. C	TEXT
6	4.b Continuous max. KVA rating at site corresponding to 50 deg. C temp rise in oil with max. ambient temp of 50 deg. C	TEXT
7	Maximum Temperature rise for top oil over an ambient temperature of 50 0C should be 50 0C maximum (measured by thermometer in accordance with IS 2026 or relevant International Standard).	TEXT
8	Maximum Temperature rise for winding over an ambient temperature of 50 0C should be 55 0C maximum (measured by resistance method in accordance with IS 2026 or relevant International Standard).	TEXT
9	No. of phases	NUMERIC
10	Voltage between phases (HV Side) at normal tap 5, in volts	TEXT

11	Voltage between phases (LV Side) at normal tap 5, in volts	TEXT
12	Connections on HV	TEXT
13	Connections on LV	TEXT
14	Vector group	TEXT
15	Frequency	TEXT
16	Tapping - Range	TEXT
17	Tapping - No of steps	TEXT
18	Method of cooling	TEXT
19	Max. core losses at normal voltage & normal frequency-KW (without IS Tol.)	TEXT
20	Max. losses at max. voltage or at 110% voltage at normal frequency - KW (without IS Tol.)	TEXT
21	Max. load losses at normal full load current- KW at 75 deg. C	TEXT
22	Resistance voltage drop of full load at normal tap at 75 deg. C in volts	TEXT
23	% Reactance drop on full load at normal tap at 75 deg. C	TEXT
24	% Impedance Voltage drop on full load at normal tap at 75 deg. C	TEXT
25	Current Density - Primary winding Amps per sq.mm.(Main & Tap)	TEXT
26	Current Density - Secondary winding Amps per sq.mm.	TEXT
27	Winding Resistance per phase in ohms at 75 deg..C for HV Winding (Main & Tap)	TEXT
28	Winding Resistance per phase in ohms at 75 deg..C for LV Winding	TEXT
29	No. of turns - HV Winding ( Main & Tap )	TEXT
30	No. of turns - LV Winding	TEXT
31	Core	TEXT
32	Grade of laminations & type of core	TEXT
33	Core material used & thickness	TEXT
34	Type of core construction	TEXT
35	Winding insulation details	TEXT
37	Type of insulation of winding - HV Side	TEXT
38	Type of insulation of winding - LV Side	TEXT
39	Class of insulation winding - HV Side	TEXT
40	Class of insulation winding - LV Side	TEXT
41	Guaranteed efficiency at standard reference temp. of 75 deg. C & normal voltage ratio in % - on 100% load at 1 p. f. Mfg. to give	TEXT
42	Guaranteed efficiency at standard reference temp. of 75 deg. C & normal voltage ratio in % - on 75% load at 1 p. f.	TEXT
43	Guaranteed efficiency at standard reference temp. of 75 deg. C & normal voltage ratio in % - on 50% load at 1 p. f.	TEXT
44	Guaranteed efficiency at standard reference temp. of 75 deg. C & normal voltage ratio in % - on 100% load at 0.8 lag p. f.	TEXT

45	Guaranteed efficiency at standard reference temp. of 75 deg. C & normal voltage ratio in % - on 75% load at 0.8 lag p. f.	TEXT
46	Regulation on full load at 75 deg. C & normal voltage ratio in % at 1 p.f.	TEXT
47	Regulation on full load at 75 deg. C & normal voltage ratio in % at 0.8 p.f.(lag)	TEXT
48	Min. Clearance to earth of primary winding in mm	TEXT
49	Min. Clearance to earth of secondary winding in mm	TEXT
50	Impulse withstand voltage on high tension winding (stating nature of impulse ) KV	TEXT
51	Type of tank	TEXT
52	Total radiating surface sq.mt. (i.e. radiators, tank-tank body & top cover ). Furnish the calculations	TEXT
53	Heat generated by the transformer for the given losses in joules, furnish the calculations	TEXT
54	Noise level at a distance of 1 m	TEXT
55	Weight of core	TEXT
56	Weight of copper in primary (HV).(Main & Tap ) per phase	TEXT
57	Weight of copper in secondary (LV) per phase	TEXT
58	Weight of core coil assembly	TEXT
59	Weight of lift for inspection (top cover)	TEXT
60	Weight of conservator with oil	TEXT
61	Weight of conservator without oil	TEXT
62	Weight of tank with radiators	TEXT
63	Weight of tank with oil & Term. Boxes (HV/LV)	TEXT
64	Weight of one radiator with oil	TEXT
65	Weight of one radiator without oil	TEXT
66	Weight of OLTC with oil	TEXT
67	Weight of OLTC without oil	TEXT
68	Weight of HV Cable Box	TEXT
69	Weight of LV Cable Box	TEXT
70	Weight of Oil only in Tank	TEXT
71	Weight of Oil only In OLTC	TEXT
72	Weight of Oil only In Conservator	TEXT
73	Weight of transformer complete with oil & all accessories	TEXT
74	Quantity of Oil Liters - In tank	TEXT
75	Quantity of Oil Liters - In conservator	TEXT
76	Quantity of Oil Liters - In OLTC	TEXT
77	Overall dimensions when installed ( with accessories fitted) - Length (mm) 5200 mm	TEXT
78	Overall dimensions when installed ( with accessories fitted) - Width (mm) 4200 mm	TEXT

79	Overall dimensions when installed ( with accessories fitted) - Height (mm) 5800 mm	TEXT
80	Transport dimensions - Length (mm)	TEXT
81	Transport dimensions - width(mm)	TEXT
82	Transport dimensions - height (mm)	TEXT
83	Head room necessary to allow removal of core in meters	TEXT
84	Available clear space of 1 m ( considering the size of transformer bay & overall dimensions of transformer ) req. all round for adequate ventilation is sufficient	TEXT
85	OLTC	TEXT
86	Details of OLTC Gear	TEXT
87	OLTC - MVA Rating	TEXT
88	OLTC - Current Rating	TEXT
89	OLTC Voltage Ratio	TEXT
90	OLTC Type of connection	TEXT
91	Particulars of OLTC gear offered make & type of the OLTC. Performance certificates attached (Yes/No)	TEXT
92	Type & Routine test certificates from CPRI attached (Yes/No)	TEXT
93	Overall dimensions	TEXT
94	Step voltage	TEXT
95	Max. Working current	TEXT
96	Value & Wattage of transition resistor	TEXT
97	Type test certificates in respect of 5/10 MVA transformer with voltage class 33 KV and 22 KV	TEXT
98	List of supplier of raw materials like copper, core, transformer oil, insulating materials etc. Details about quality control methods adopted to assess the quality of raw/ finished material	TEXT
99	List of plant machinery & testing equipments indicating their ratings & make, for carrying out all routine/acceptance tests & certain type tests such as Heat Run at full load, Impulse test , Noise level measurement etc.	TEXT
100	Drawings:	TEXT
101	Dimensional drawings of the transformer with radiators, conservators etc. fitted. General arrangement drawing one sheet comprising of plan, elevation, side view of the complete transformer & other details like legends, untanking height, clearance etc. also all above drawings in separate sheets	TEXT
102	Transport outline of the transformer including transport weight	TEXT
103	Rating & Diagram plate. Connection diagram of the transformer winding showing the position of tapping etc.	TEXT
104	Bushings (primary & secondary) drawings.	TEXT
105	Cable box assembly (LV) drawing along with support arrangement	TEXT
106	Cable box assembly (HV) drawing alongwith support arrangement	TEXT
107	Dimensional drawings of the OLTC gear (internal details).	TEXT
108	Schematic diagram of the OLTC arrangement for Transformer operating independently.	TEXT

## Required Documents (To be uploaded online)

Sr. No.	NAME	SECTION	ITEM	DESCRIPTION
1	TTR	Technical Section	33 11 KV, 5 MVA POWER	Submit Type test certificates from NABL accredited lab such as CPRI/ERDA of offered Item valid for a period of five years.
2	TTR	Technical Section	33 11KV, 10MVA POWER	Submit Type test certificates from NABL accredited lab such as CPRI/ERDA of offered Item valid for a period of five years.
3	Submit List of in house manufacturing and testing facilities as well as quality control set up	Commercial Section		Submit List of in house manufacturing and testing facilities as well as quality control set up available with the tenderer duly seal and signed.
4	ISO	Commercial Section		Submit ISO for quantity management system and ISO for environmental management system.
5	Turnover	Commercial Section		Submit documentary evidence showing annual turnover of last 3 years, certified by Chartered Accountant for preceding three financial years.
6	Submit Self-undertaking on bidders letter head for not approaching any one for undue influence.	Commercial Section		Submit Self-undertaking on bidders letter head for not approaching any one for undue influence.
7	Submit Udyam registration.	Commercial Section		Submit Udyam registration.
8	Submit EMD receipt (Bank Guarantee or Demand Draft).	Commercial Section		Submit EMD receipt (Bank Guarantee or Demand Draft).
9	Submit Notarized power of attorney in favor of appointed agent/representative.	Commercial Section		Submit Notarized power of attorney in favor of appointed agent/representative.
10	Submit Certificate from Chartered Accountant for not having controlling stake in more than one entity.	Commercial Section		Submit Certificate from Chartered Accountant for not having controlling stake in more than one entity.
11	Submit declaration along with bid as per Clause no. XXXII of Section I regarding corrupt and fraudul	Commercial Section		Submit declaration along with bid as per Clause no. XXXII of Section I regarding corrupt and fraudulent practice.
12	Submit Annexure-F regarding declaration of legal litigations.	Commercial Section		Submit Annexure-F regarding declaration of legal litigations.
13	Submit Annexure-I regarding debar undertaking.	Commercial Section		Submit Annexure-I regarding debar undertaking.
14	List of orders in hand.	Commercial Section		List of orders in hand.
15	Experience	Commercial Section		Copies of orders executed by the bidder and order Completion certificate with regards to successful execution of the order / supply of quantity for preceding three financial years as per Qualifying



Sr. No.	NAME	SECTION	ITEM	DESCRIPTION
16	Submit GST registration certificate.	Commercial Section		Submit GST registration certificate.