

Tender Details		18-05-2023 02:43:10
Tender Code	MMD/T-HTM1-03/0523	
Tender Type	Procurement Tender	
Type Of Bid	Two Bid	
Description	Procurement of 11/3/0.25KV, 25 KVA, Single Phase Outdoor Type Distribution Transformer (EEL-1) without CSP Feature	
Estimated Cost (In Lakhs)	4574	
Basis of prices	Firm Price Basis	
Tender Validity	120	
Delivery Requirement (In Months)	9	
Tender on rate contract basis	NO	
Tender Fee (In INR)	25000	
GST In INR (@18% on Tender Fee: SAC No.	4500	
Total Tender Fee Amount including GST in INR.	29500	
Contact	Shri Anil L Nagare , 9960675991 ,cemmcsedcl@gmail.com	
Pre-Qualifying Req	As per tender documents	
Budget Type	NA	
Scheme Code		
Scheme Name		
Department	Material Management Cell	
Office Type	HO	
Location Type	Corporate Office	
Designation	Executive Engineer(Distribution)	
Pre-Bid Meeting Address	OFFICE OF THE CHIEF ENGINEER, Maharashtra State Electricity Distribution Co. Ltd. Material Management Department, Plot No. G-9, "Prakashgad" First floor, Prof. A.K. Marg,Bandra (E), Mumbai – 400 051. E-mail- cemmcsedcl@mahadiscom.in,cemmcsedcl@g	
Bid Opening Address	OFFICE OF THE CHIEF ENGINEER, Maharashtra State Electricity Distribution Co. Ltd. Material Management Department, Plot No. G-9, "Prakashgad" First floor, Prof. A.K. Marg,Bandra (E), Mumbai – 400 051. E-mail- cemmcsedcl@mahadiscom.in,cemmcsedcl@g	
Version No	1	
Call for Deviation	YES	
Is Annexure C1 Applicable	YES	
Is Manufacturer Applicable	YES	
Is Trader Applicable	NO	
Minimum % of Offered Quantity	20	
Is Power Supplier Applicable	NO	
Tender Sale Start Date	18-05-2023 17:00	
Tender Sale End Date	08-06-2023 12:00	
Bid Start Date	18-05-2023 17:30	

Bid End Date	08-06-2023 15:00
Pre-Bid Meeting Date	25-05-2023 17:00
Techno-Commercial Bid opening on	08-06-2023 15:30
Price Bid opening on	Will be declared later
Annexure C1 Opening Date	Will be declared later
Winner Selection Date	Will be declared later
Can Bidder opt for EMD Exemption	YES
Is Annexure-E [Consent for MSEDCL Standard Technical Specifications and GTP] Applicable ?	NO



MATERIAL MANAGEMENT DEPARTMENT
 MAHARASHTRA STATE ELECTRICITY DISTRIBUTION CO. LTD.
 Tender No. MMD/T-HTM1-03/0523

TENDER BID NOTICE

The Chief Engineer, Material Management Department (MMD), on behalf of Maharashtra State Electricity Distribution Company Limited (the Purchaser), hereby invites sealed bids from eligible bidders for procurement of 11/√3/0.25KV, 25 KVA, Single Phase Outdoor Type Distribution Transformer (EEL-1) without CSP Feature. Entire bidding document is available online on <https://etender.mahadiscom.in/eatApp/> as per date indicated below. Any changes in the Bid Schedule, corrigendum etc. shall also be notified via MSEDCL's website. Prospective bidders are therefore requested to regularly check the website for any updates.

Tender No. MMD/T-HTM1-03/0523

Estimated Tender Cost: Rs. 45.74 Crore inclusive of 18% GST.

Tender Fee: Rs. 25,000.00 + 18% GST

The bidder should submit non-refundable Bid Fee of Rs. 25,000.00 + 18% GST paid through online payment only, prior to the dead line for submission of bids as per the procedure laid by the MSEDCL.

Earnest Money Deposit: The bid must be accompanied with EMD @ 0.5% (Half Percent) value of the estimated cost of offered quantity of the tender in the form of BG as per the Annexure-M enclosed with tender documents having validity of 120 days from opening of tender. Interest shall not be allowed on EMD.

The scanned copy of the online payment receipt / Demand Drafts / BG should be uploaded (in e-tendering) and the Demand Drafts/BGs should be submitted to this office on or before submission date and time.

Calendar of Events Event	Date and Time
Begin Sale of Bid Document	18.05.2023
Date and time of submission of Bids	08.06.2023 at 15:00 hrs.
Date and time of Bid Opening	08.06.2023 at 15:30 hrs.
Date and time of Pre bid meeting	25.05.2023 at 17:00 hrs. Online Google Meet joining info : https://meet.google.com/hhx-huxg-yhm

THE CHIEF ENGINEER
Maharashtra State Electricity Distribution Co. Ltd.
Material Management Department,
Plot No. G-9, "Prakashgad" First floor, Prof. A. K. Marg,
Bandra(E), Mumbai-400051.
E-mail- cemmcmedcl@mahadiscom.in, cemmcmedcl@gmail.com

MAHARASHTRA STATE ELECTRICITY DISTRIBUTION CO. LTD.

TENDER FOR

Procurement of 11/√3/0.25KV, 25 KVA, Single Phase
Outdoor Type Distribution Transformer (EEL-1)
without CSP Feature.

Tender No: MMD/T-HTM1-03/0523



**OFFICE OF THE CHIEF ENGINEER,
Maharashtra State Electricity Distribution Co. Ltd.
Material Management Department,
Plot No. G-9, "Prakashgad" First floor, Prof. A. K. Marg,
Bandra (E), Mumbai – 400 051.
E-mail- cemmcmsedcl@mahadiscom.in
cemmcmsedcl@gmail.com**

=====

INDEX

SR. NO.	CLAUSE NO.	DESCRIPTION
1	-	BID NOTICE
2	-	SECTION I: INVITATION TO TENDER AND INSTRUCTION TO BIDDERS
3	I	SCOPE OF WORK
4	II	QUALIFYING REQUIREMENTS
5	III	PRICES
6	IV	TAXES
7	V	BASIS OF PRICES
8	VI	PRICE VARIATION
9	VII	DELIVERY
10	VIII	OFFERING THE MATERIAL
11	IX	CONFLICT OF INTEREST
12	X	QUOTATION
13	XI	AMBIGUITY IN QUOTATION
14	XII	FILLING IN OF ANNEXURE
15	XIII	ADDITIONS/ALTERATIONS PROHIBITED
16	XIV	BIS LICENSE AND BEE CERTIFICATE
17	XV	MANDATORY REQUIREMENT OF SUBMISSION OF OFFER
18	XVI	SUBMISSION OF DRAWING & BILL OF MATERIAL
19	XVII	NAME OF AUTHORIZED REPRESENTATIVE
20	XVIII (A)	OFFER OF MICRO & SMALL ENTERPRISES
21	XVIII (B)	PREFERENCE TO INDUSTRIAL UNITS LOCATED IN MAHARASHTRA AND OFFERS BY MATCHING RATES WITH LOWEST ACCEPTABLE BIDDER
22	XVIII (C)	MATCHING OF RATES
23	XIX	QUANTITY ALLOCATION
24	XX	EARNEST MONEY DEPOSIT (EMD)
25	XXI	SIGNING OF THE TENDER DOCUMENTS
26	XXII	SUBMISSION / SUPERSCRIBING OF THE TENDER DOCUMENTS
27	XXIII	TIMELY SUBMISSION OF OFFER
28	XXIV	PURCHASER'S RIGHT
29	XXV	DISREGARD OF TENDER CONDITIONS
30	XXVI	PROHIBITION FOR POST TENDER CORRESPONDENCE
31	XXVII	RIGHT TO ORDER OUT QUANTITY IN VARIANCE TO OFFERED QUANTITY
32	XXVIII	ACCEPTANCE OF TENDER
33	XXIX	NOTIFICATION OF AWARD
34	XXX	EARNEST MONEY OF UNSUCCESSFUL BIDDER
35	XXXI	VALIDITY OF OFFERS
36	XXXII	DECLARATION FROM BIDDER
37	XXXIII	CORRUPT OR FRAUDULENT PRACTICES
38	XXXIV	INFLUENCE
39	XXXV	TENDER FEES EXEMPTION
40	XXXVI	PRE-BID MEETING
41	XXXVII	CLARIFICATION ON DEVIATIONS
42	-	CERTIFICATE
43	-	Section II: CONDITIONS OF SUPPLY
44	1	EFFECT OF CONTRACT
45	2	QUALITY OF SUPPLIES

SR. NO.	CLAUSE NO.	DESCRIPTION
46	3	MATERIAL AND COMPONENTS
47	4	ACCEPTANCE OF SUPPLIES/INSPECTION
48	5	RIGHT TO CARRY OUT INSPECTION DURING MANUFACTURING
49	6	RIGHT TO REVISE DESPATCH INSTRUCTIONS, DELIVERY SCHEDULE AND TO DEFER SUPPLIES
50	7	WAGAN LOADS/TRUCK LOADS
51	8	ROAD TRANSPORT
52	9	DESPATCH INTIMATION
53	10	BILL OF MATERIALS
54	11	PACKING LIST
55	12	REPLACEMENT OF GOODS LOST, BROKEN OR DAMAGED
56	13	REPLACEMENT OF REJECTED MATERIALS
57	14	MATERIAL DESPATCHED AND PROGRAMME
58	15	MATERIAL RECEIPT & SUBMISSION OF BILLS AT CONSIGNEE
59	16	PAYMENT OF BILLS
60	17	TAXES
61	18	DEDUCTION
62	19	GUARANTEE
63	20	(I)LIFTING OF REJECTED/DAMAGED MATERIALS FROM STORES AND (II)LIFTING OF FAILED TRANSFORMERS FROM DIVISION FILTER UNIT
64	21	LIQUIDATED DAMAGES FOR LATE DELIVERY
65	22	ORDER PLACED ON TIME PREFERENCE BASIS (WHEREVER APPLICABLE)
66	23	FORCE MAJEURE CLAUSE
67	24	ACCEPTANCE OF LOWER FORD RATE OFFERED IN SUBSEQUENT TENDER
68	25	PERFORMANCE OF CONTRACT:
69	26	CONTRACT PERFORMANCE DEPOSIT
70	27	POWER OF ATTORNEY:
71	28	SETTLEMENT OF DISPUTE
72	29	JURISDICTION:
73	30	TERMINATION OF CONTRACT
74	31	DEBAR / BLACKLISTING OF MANUFACTURER
75	32	TAX DEDUCTED AT SOURCE
76		Section III:
77	I	QUANTITY PROCUREMENT
78	II	QUALIFYING REQUIREMENT
79		Formats:
80	-	ANNEXURE B- QUANTITY, PRICE AND DELIVERY PERIOD
81	-	<u>ANNEXURE C-1 : MATCHING RATE</u>
82	-	<u>ANNEXURE - D : TECHNICAL SPECIFICATION</u>
83		ANNEXURE - E : CONSENT FOR MSEDCL STANDARD TECHNICAL SPECIFICATIONS & GTP
84		ANNEXURE - F : LEGAL LITIGATION UNDERTAKING BY BIDDER
85	-	ANNEXURE - G :PRICE VARIATION
86	-	ANNEXURE - H :GUARANTEED TECHNICAL PARTICULAR
87		ANNEXURE - I: DECLARATION FORMAT.
88	-	ANNEXURE - J : DISPATCH INSTRUCTIONS
89	-	ANNEXURE - K : LIST OF STORES
90		ANNEXURE - L : INSPECTION CALL FORMAT
91	-	ANNEXURE - M : BANK GUARANTEE FORMAT FOR EMD

SR. NO.	CLAUSE NO.	DESCRIPTION
92	-	ANNEXURE – N : BANK GUARANTEE FORMAT FOR CONTRACT PERFORMANCE DEPOSIT
93	-	ANNEXURE – O : CONSENT FOR PARTICIPATION IN TENDER AS NEW SUPPLIER
94		FORMAT-1 : ANNEXURE – U-I - INDEMNITY BOND
95		FORMAT-2 : UNDERTAKING FOR NOT APPROACHED ANY ONE FOR UNDUE INFLUENCE
96		FORMAT-3 : CERTIFICATE FROM CHARTERED ACCOUNTANT FOR NOT HAVE CONTROLLING STACK IN MORE THAN ONE ENTITY APPLIED FOR THE TENDER / BID
97		FORMAT-4 : CERTIFICATE FROM CHARTERED ACCOUNTANT FOR AVERAGE ANNUAL TURNOVER
98		FORMAT-5 : CERTIFICATE FOR NO DEVIATION

SECTION-I

INVITATION TO TENDER AND INSTRUCTION TO BIDDERS

TENDER FORM (NOT TRANSFERABLE)

(TO BE SUBMITTED ONLINE DULY FILLED IN AND DIGITALLY SIGNED)

To be submitted online not later than the date mentioned in the tender details. For participating in tender opening, the bidder can login at the specified time and date of opening of the tender, if he desires so.

The bidder is requested to quote his lowest rates F.O.R. destination for the supply of materials. The material is required at various places in the State of Maharashtra. The tender documents duly filled-in and digitally signed, are to be submitted online before due time & date of the submission of tender in prescribed form.

The modifications made to the terms & conditions shall applicable to this tender only.

FOR CHIEF ENGINEER (M.M.DEPARTMENT)

=====

INSTRUCTIONS TO THE BIDDERS

I SCOPE OF WORK:

The scope of work under this tender is for design, engineering (wherever applicable), manufacture, inspection & testing before dispatch, packing and supply of material / equipment as specified in Annexure-D (Technical Specifications) at various destination sites / stores centers of the purchaser in Maharashtra.

The actual quantity that will be procured may vary depending upon the site requirement. The quantity advertised against various capacities can undergo change.

The list of various destination sites / stores centers of the purchaser is enclosed as Annexure K.

II Qualifying Requirements:

Qualifying requirement will be as per Section-III.

III PRICES:

(i) Prices are acceptable only on F.O.R. destination basis inclusive of Goods and Service Tax (GST for brevity) i.e. Integrated GST (IGST) for outside State / Central GST+ State GST (CGST+SGST) for within State, risk in transit, freight showing the break-up as desired in the Annexure 'B'. It shall be noted that quotations not conforming to F.O.R. destination basis inclusive of IGST/(CGST+SGST) etc. and to the unit as specified in Annexure 'B', shall be rejected even though the bidder's offer may be lowest. The bidder shall quote Ex-Works Price and element of freight and insurance along with applicable rate of IGST/(CGST+SGST). The F.O.R. destination price i.e. up to site or the Store Centre of the purchaser as the case may be inclusive of IGST/(CGST+SGST), risk in transit and freight will be programmatically calculated. While raising the invoices, however, IGST/(CGST+SGST) should be shown separately in the invoice raised.

(ii) For each of the items quoted, bidder shall specify offered quantity. However, the offered quantity shall not be less than 20% of the advertised quantity (Advertised quantity means the quantity required as indicated in Annexure 'B' / Price Bid) so as to deliver the said quantity within the delivery requirement of the Purchaser as indicated in the tender documents.

IV TAXES:

(i) The Purchaser shall be registered under Goods and Service Tax Act and should comply with all the statutory compliance requirements of GST Law diligently.

(ii) It is imperative for the bidder to indicate the amount of IGST/(CGST+SGST) included in their price while giving the break-up of F.O.R. destination price in Annexure 'B', failing which, the offer will be treated as ambiguous and will be rejected as per the provisions of clause X of tender form.

(iii) After awarding the contract, the supplier shall not charge any additional amount towards GST; during the currency of contract except statutory variation by Central / State Government in normal (full) rate of integrated GST. In case the GST is decreased than the rate indicated in the price bid, the benefits of the

reduction in the GST shall be passed on to the purchaser. The increase in the GST rate due to increase in turnover during the contractual delivery period shall not be charged to the purchaser.

- (iv) Necessary documentary evidence for the GST claimed shall be submitted along with the bills.

V BASIS OF PRICES:

The bidder shall quote the prices on firm price basis, as has been specifically brought out in the Tender Details. For any deviation in this regard, the offer shall be summarily rejected.

VI PRICE VARIATION:

Not applicable.

VII DELIVERY:

- (i) Bidder is requested to quote delivery F.O.R. DESTINATION only & only in the unit of the item specified in Annexure 'B' i.e. if the quantity is in sets or in tones or in numbers or in kilometers or in coils, the rate of delivery shall only be in the same unit.
- (ii) It is mandatory on the part of the tenderer to quote the delivery on monthly basis. If the offered delivery is indicated on quarterly basis, then the delivery would be counted proportionately in three equal installments per month for liabilities of the contract including levy of liquidated damages.
- (iii) Size mix for the purpose of delivery, when delivery is quoted in assorted items, shall be determined by the Purchaser while issuing the A/T or dispatch instructions and will be binding on the bidder. The Purchaser will also have the liberty of modifying the size mix for the purpose of delivery, even after the A/T is issued.
- (iv) Offer shall be rejected if the commencement period and rate of delivery per month is not indicated.
- (v) The scheduled delivery period is 9 months from the letter of award will be as below;
- Commencement Period (CM): Min. 10% of offered quantity within 2 months.
- Completion Period (CP): Balance offered quantity in 7 or less months in equated lots.
- (vi) MSEDCL may issue dispatch instructions as per requirement. The quantity demanded per consignee may be less than or equal to monthly lot specified in contract. Wherever as per demand, if the quantity to be supplied to a consignee in a particular month is less than monthly lot quantity; the said quantity will be treated as lot quantity for the purpose of delivery and payment.
- (vii) MSEDCL may instruct the supplier to withhold entire or part of monthly supply of material for a specified period by giving two months advance instruction.
- (viii) Time being the essence of contract, the supplier shall strictly maintain monthly delivery schedule.

=====

The bidder is advised to get their type tests & drawing approval immediately after placement of LoA from Chief Engineer (Testing & QC) so that the material is received by the purchaser well within the committed delivery period. If there is any delay in delivery of material as per schedule, the undelivered quantity as per schedule can be diverted to other good performing bidder.

VIII OFFERING THE MATERIAL:

- (A) The bidder shall offer the material as per MSEDCL technical specifications as per Annexure-D and shall have to fill the entire GTP.
- (B) The person / entity should not have controlling stake in more than one entity applied for the tender / bid. **Necessary certificate duly certified by Chartered Accountant to this effect shall be submitted along with the tender documents.**
- (C) Factory address, from which the bidder intends to supply the material against the tender, shall be as indicated in the latest approved online vendor registration form on e-tendering through which the vendor is submitting the offer.
- (D) The bidder shall offer the rates, taxes as applicable for the factory location indicated in his latest approved online vendor registration form on e-tendering through which he is submitting his offer.

IX CONFLICT OF INTEREST

A bidder may be considered to have a conflict of interest with one or more parties in a bidding process if they:

- (a) Have controlling shareholders in common; or
- (b) Receive or have received any director in direct subsidy from any of them; or
- (c) Have the same legal representative for purposes of a bid; or
- (d) Have a relationship with each other, directly or through common third parties, that puts the mina position to have access to information about or influence on a bid of another bidder, or influence the decisions of the purchaser regarding the bidding process.

Bidders found to be in conflict of interest, shall be disqualified.

X QUOTATION:

- (i) Bidder shall quote his rate per unit specified in Annexure 'B' / Price Bid in figures.
- (ii) Bidder's printed terms and conditions will not be considered as forming part of the tender.

XI AMBIGUITY IN QUOTATION:

The bidder is requested to please make a note that in case of ambiguous terms in respect of offered quantity in Annexure- B and schedule 'C', F.O.R. condition, GST, basis of price (i.e. firm / variable) or if the blanks are left out in the offer, the item / tender shall be rejected.

XII FILLING IN OF ANNEXURE:

The bidder is requested to ensure that the comments against each and every item/clause of Annexure shall be clearly filled in and answered. Any item/clause shall not be left

blank or unanswered. If any item /clause is not applicable, the “Not Applicable (N.A.)” check box shall be selected.

XIII ADDITIONS/ALTERATIONS PROHIBITED:

The bidder shall not make any additions, alterations or changes in the Tender Form and the Conditions of Tender & Supply (Annexure ‘A’) including the description of material mentioned in Annexure ‘B’. They should quote rate for the material described or click the check box ‘Not quoted’ against each of the item in Annexure ‘B’/ Price Bid.

XIV B.I.S. LICENCE AND BEE CERTIFICATE :

A scanned copy of valid BIS License & BEE certifications for offered items ratings duly sealed & signed must be uploaded and submitted along with offer, failing which, the offer shall be rejected.

In case the validity of the BIS license / BEE certifications is expiring before date of submission of tender, necessary documentary proof of having applied for renewal of validity of the BIS license / BEE certifications must be uploaded while submitting the bid. The renewed copy of the BIS License / BEE certifications shall be submitted before commencement of supply.

However, valid BIS license / BEE certifications scan copy of offered material must be submitted by the qualifying bidders before commencement of supply, failing which their order will be cancelled with financial liability on supplier.

XV MANDATORY REQUIREMENT OF SUBMISSION OF OFFER:

The offer shall be submitted online duly filled in; attaching all the required documents, completed in all respects and should be digitally signed.

XVI SUBMISSION OF DRAWING & BILL OF MATERIAL:

The bidder shall submit the drawings and bill of material conforming to the tender specification wherever applicable. In such cases, the offer without the drawings and bill of material shall not be evaluated and considered. The drawings and bill of material submitted along with the bid shall not be considered for evaluation of the offer but the drawings and bill of material of the successful bidder shall be scrutinized when the Purchaser decides to accept such bid. It may, however, be noted that Purchaser’s action of evaluation of the tendered bid would not mean approval of the drawings and bill of material submitted along with the tender bid.

The bidder shall depute his authorized representative for discussion on the drawings, either immediately on hearing from the Purchaser or after receipt of Letter of Award. The formalities like submission of drawings, bill of material etc. and getting the same approved by the Purchaser shall be completed by the successful bidder within TEN DAYS from the date of Letter of Award of the contract. The approval to drawings complete in all respects mentioned in technical specifications (Annexure-D) will be accorded within SEVEN working days thereafter. Any delay in this regard shall lead to cancellation of the Letter of Award at the risk and cost of the bidder. The supplies against the contract shall conform to the approved detailed drawings / bill of material and the detailed technical specifications.

XVII NAME OF AUTHORIZED REPRESENTATIVE:

The digital certificate shall be in the name of person authorized by the firm. In case, the digital certificate is compromised or the person holding the digital certificate is no longer authorized to digitally sign the tender, it is the responsibility of the bidder to revoke this certificate and obtain the fresh certificate. While submitting the bids online only valid digital certificate shall be used. The vendors are requested to check the validity of digital signature and prior to the expiry date & they are requested to get their Digital signature key validated before expiry of the same. MSEDCL shall not be responsible for Non-submission of any of the Bids (Techno Commercial Bid, Deviation Bid, Price Bid, Annexure - C-1) by vendors due to expired/Invalid Digital signature.

The bidder is responsible for all the contractual liabilities and responsibilities thereof.

In case the bidder authorizes the representative to deal on behalf of the bidder, the name and address of such person should be informed to the purchaser. The bidder shall submit the power of Attorney in favour of representative duly executed before the Notary. In the absence of the Power of Attorney, the purchaser shall not deal with the representative.

XVIII (A) Offer of Micro & Small Enterprises: (If matching is called)

The bidder registered with Directorate of Industries of Government of Maharashtra for manufacturing the items tendered/offered and those who have attached valid certificate at the time of vendor registration shall be considered for concessions applicable and procurement of reserved items as per GoM G. R. dtd. 30-10-2015 amended up to date. These benefits shall be available only to those items approved during the registration process and subsequent updates in registration up to the submission of this tender.

Based on concession of Central Government's Micro & Small Enterprises office order dtd. 23-03-2012, 241 items are being kept reserved. As per above reservation of items 100% reserved items to be purchased from Micro & Small Enterprises out of which 20% reserved items to be purchased from S.C./S.T. enterprises. Reservation is applicable for a limited period unless & until re-examined. If Micro & Small Enterprises participated in the tender and the tendered item is not reserved, then 20% order with L-1 rate to be given to Micro & Small Enterprises and out of this 20%, 4% to be given to S.C./S.T. enterprises.

If there are any specific Government Directives such as reservation of items for units in Maharashtra, non-eligibility of preference to SSI units etc. for particular items, price and purchase preference etc. the same would be applicable irrespective of the fact that it has not been specifically incorporated in the tender notice and/or tender documents.

(B) PREFERENCE TO INDUSTRIAL UNITS LOCATED IN MAHARASHTRA AND OFFERS BY MATCHING RATES WITH LOWEST ACCEPTABLE BIDDER

The lowest acceptable rate will be the unit rate worked out without considering IGST/(CGST+SGST) as applicable and the same rate will be considered as applicable to the respective bidder who has agreed to accept order at lowest acceptable rate.

(C) Matching of rates:

The confirmation for acceptance of the order at the lowest acceptable rate indicated as above shall be given in the format as per Annexure 'C-1' of the tender documents. The same should be submitted online on or before the due time and date of submission of Annexure 'C-1'. The confirmation shall be opened online on due time and date of opening of Annexure 'C-1'. Schedule for submission and opening of Annexure 'C-1' shall be communicated separately by e-mail and on the website. Though confirmation in Annexure 'C-1' as above is called from all the qualified bidders, the bidders, who quoted rates within the range of 5% in comparison with the lowest acceptable rates, shall only be considered and their Annexure 'C-1' will be opened on the date and time intimated subsequently in the presence of bidders who chose to be present. Provided, however, that the Annexure 'C-1' of the bidders, who have quoted above the range of 5% in comparison with the lowest acceptable rates, shall also be considered in case the aforesaid bidders within the range of 5% are unable to fulfill the quantity requirement. In that case also, the date of opening of Annexure 'C-1' will be intimated to the bidders

- 1) In the above confirmation, if the bidder indicates any rate, then the confirmation given by the bidder will not be considered as valid.
- 2) The prices indicated in the original offer shall not be considered as valid once offer for acceptance of order by matching rates is given. In the event of withdrawal of offer by matching rates within the validity period, the entire offer against the tender shall become invalid and shall be summarily rejected and the earnest money paid by the bidder shall be forfeited.
- 3) The lowest acceptable rate is known only on the date of decision by the Competent Authority, hence the lowest acceptable rates of the tender cannot be declared in advance, however lowest acceptable rate of the tender would be equal to or more than the lowest rate received in the tender.

XIX QUANTITY ALLOCATION:

- 1) If L-1 bidder is within Maharashtra State and if total tender quantity for quoted item is offered by L-1 then 100% quantity will be awarded to L-1 bidder for quoted item.
- 2) If L-1 bidder is within Maharashtra State and offered quantity is less than the tender quantity for quoted item then,
 - a) Quantity allotted to L-1 bidder will be equal to quantity offered by him.
 - b) Balance quantity after allotment as (a) above, will be distributed among Maharashtra State bidders as per their price ranking (if ready to match with L-1 rate) subject to maximum 50% of total tender quantity for quoted item to Maharashtra State bidders including L-1 bidder.
 - c) Any balance quantity after allotment as (a) & (b) above, will be distributed as per their price ranking (if ready to match with L-1 rate) irrespective of bidder is Maharashtra or out of Maharashtra state bidder including partial allotment if any to Maharashtra bidder in (b) above.
- 3) If L-1 bidder is outside Maharashtra State then,

- =====
- a) If the L-1 bidder offered more than 50% of tendered quantity for quoted item then maximum of 50% of tender quantity for quoted item will be allotted to L-1 bidder.
 - b) If the L-1 bidder offered less than 50% of tendered quantity for quoted item then quantity equal to offered quantity for quoted item will be allotted to L-1 bidder.
 - c) Balance quantity after allotment as (a) or (b) above, will be distributed among Maharashtra State bidders as per their price ranking for 50% of required quantity (if ready to match with L-1 rate).
 - d) Any balance quantity after allotment as (a), (b) & (c) above, will be distributed as per their price ranking (if ready to match with L-1 rate) irrespective of bidder is Maharashtra or out of Maharashtra state bidder including partial allotment if any.
 - e) If all bidders including L-1 bidder are from outside Maharashtra state and if the offered quantity of L-1 bidder is 100 % then entire quantity will be allotted to L-1 bidder. If quantity offered by L-1 bidder is less than 100 %, then after allotting to L-1 bidder balance quantity will be allocated to remaining bidder who matched the L-1 rates as per price ranking & quantity quoted.
 - f) In spite of above the quantity allocation will be at the sole discretion of MSEDCL.
- 4) If new suppliers are allowed then maximum 20% of tender quantity will be reserved for new supplier as per their price ranking.

XX EARNEST MONEY DEPOSIT (EMD):

The bidder should pay the Earnest Money @ 0.5% (Half Percent) value of the estimated cost of offered quantity of the tender in the form of Demand Draft or Bank Guarantee as per the Annexure-M enclosed with tender documents having validity of 120 days from opening of tender. Interest shall not be allowed on EMD. EMD shall be forfeited (i) in case the bidder withdraws the tender / offer during the validity period (ii) in case the bidder fails to pay the performance deposit if the contract is awarded.

However, bidders from the following categories are exempted from payment of earnest money deposit.

- 1) All Government and semi Government institutions under Govt. of Maharashtra and Zilla Parishad in Maharashtra and fully owned undertaking of any State Govt. and Govt. of India only for the items manufactured by such institutions.
- 2) Micro and Small Enterprises registered under Micro, Small and Medium Enterprises Development Act-2006 only for the items mentioned in their permanent registration certificate at the time of vendor registration.
- 3) The bidder registered with N.S.I.C. and those who have attached valid N.S.I.C. Registration Certificate for the items mentioned in their permanent registration certificate at the time of vendor registration.

=====

The benefits mentioned in (1) to (3) above shall be available only to those items approved during the registration process and subsequent updates in registration up to the date of submission of this tender.

Exempted bidders should upload a latest valid certificate issued by any approved body of 'Ministry of Small & Medium Enterprises' (MSME) such as 'National Small Industries Corporation' (NSIC) or 'Udyam registration' for EMD exemption.

XXI SIGNING OF THE TENDER DOCUMENTS:

Offer shall be submitted along with the tender documents and duly filled in with all Sections / Annexures / Appendixes / Schedules etc. The offer shall be signed with valid digital signature.

XXII SUBMISSION / SUPERSCRIBING OF THE TENDER DOCUMENTS:

The offer is to be submitted as follows.

(a) Online Submission:

- (i) Techno-Commercial Bid (Part-I): This part shall contain all technical and commercial aspects of the bid and documents supporting the same except the Price Bid.

The bidder is requested to please make a note that in case of the Price Bid (Part-II) is submitted instead of Techno-Commercial Bid in Part-I or submitted Price Bid (Part-II) along with Techno-Commercial Bid in Part-I, the offer shall be rejected.

- (ii) Price Bid (Part-II)

This part shall contain only the Price Bid strictly in the prescribed format, i.e. Annexure 'B'.

(b) Off line Submission:

Physical submission of documents (Part-III) – Not mandatory.

Envelope for this part shall contain documents like Type Test Reports, Drawings, Bill of Material, Catalogues etc. wherever applicable as per technical specification and they shall be scanned and these scanned documents to be taken into PDF format on CD media (2 sets) and are to be submitted to Executive Engineer (HTM-1) in the office of Chief Engineer, Material Management Department in sealed envelope on or before due date & time of submission.

METHOD OF SUBMISSION OF PART-III AND THEIR OPENING:

This envelope shall be individually sealed and shall be superscribed with the name and address of bidders and the following information before posting or delivering the same:

- i. Tender No.
- ii. Due date and time of submission.
- iii. Due date and time of opening.

Envelope as above shall be submitted on or before the prescribed due date and time of submission and shall be opened on due date and time of opening as prescribed.

=====

In case of bidders whose techno-commercial bid is acceptable, their Price Bids will be opened at a later date. This date shall be intimated to such bidders separately.

XXIII TIMELY SUBMISSION OF OFFER:

- (a) The bid is to be submitted online on or before due date and time of submission to the Purchaser at website.
- (b) It is advisable to submit the digitally signed offer sufficiently in advance of due date and time so as to avoid last minute congestion of network / server.
- (c) Offer received after the due date and time of submission shall not be accepted.
- (d) In case, the due date of opening of tender happens to be holiday, the offer shall be opened on the next working day at the same time.

XXIV PURCHASERS RIGHT:

The Purchaser reserves the right to reject any offer without assigning any reason whatsoever.

The Purchaser reserves the right to make any changes in terms & condition at any stage of the process without assigning any reason whatsoever.

If any type of legal litigation against MSEDCL is pending in any court/Forum against/by the bidder or its sister concern/Director/Partner/Proprietor, then purchaser reserves the right to reject partly or fully their bid without assigning any reasons thereof.

Bidder has to submit the declaration as per Annexure-F regarding no any type of legal litigation against MSEDCL is pending in any court/Forum against/by the bidder or its sister concern/Director/Partner/Proprietor.

XXV DISREGARD OF TENDER CONDITIONS:

Tender containing any deviations / additions / alterations / changes in the conditions of the tender and supply as stated in Annexure 'A', 'B', 'C-I', 'D', 'E' and schedule 'C' shall not be acceptable.

The bidder having digitally signed all the tender documents indicates any deviations / additions / alterations / changes in the covering letter, unrelated annexure and schedules of the offer or elsewhere, the same shall be ignored and the offer shall be treated as meeting with all specified tender conditions.

XXVI PROHIBITION FOR POST TENDER CORRESPONDENCE:

The Bidder should note that no correspondence shall be entertained or considered after the due date and time of submission of tender unless otherwise sought by the Purchaser.

The Bidder should also note that no correspondence shall be entertained or considered after the placement of LoA/AT unless otherwise sought by the Purchaser.

XXVII RIGHT TO ORDER OUT QUANTITY IN VARIANCE TO OFFERED QUANTITY:

The Purchaser reserves the right to order out / procure any quantity in excess of the offered quantity with change in delivery period with mutual consent. The quantity specified may be for dispatch to one destination or several places.

XXVIII ACCEPTANCE OF TENDER:

The Purchaser does not bind itself to accept the lowest or any tender; neither will any reasons be assigned for the rejection of any tender or part of tender. It is also not binding on the Purchaser to disclose any analysis report on tender/samples. The bidder on his part binds himself to supply any item or items selected from his offer in part or whole at the option of the Purchaser.

XXIX NOTIFICATION OF AWARD:

Notification of Award of contract will be made by a letter of Award, to be sent by registered post or given by hand or by E-mail to the successful bidder by the Purchaser. It could also be made by e-mail to be confirmed in writing by registered post to the successful bidder by the Purchaser.

XXX EARNEST MONEY OF UNSUCCESSFUL BIDDER:

Earnest money deposit will be returned to the unsuccessful bidder by RTGS within 7 (seven) working days after the tender has been decided and on submission of receipt of E.M.D. payment to the G.M. (F&A-SB), MSEDCL, Prakashgad, Prof. A.K. Marg, Bandra (East), Mumbai-400051. Earnest money deposit in the form of BG will be returned to the unsuccessful bidder within 7 (seven) working days by Chief Engineer, Material Management Department after the tender has been decided.

XXXI VALIDITY OF OFFERS:

The bidder shall keep the offer valid for acceptance up to and including last date of calendar month, covering the date of completion of 120 days (one hundred and Twenty days) from the date of opening of the tender and shall also agree to extend the period of validity required by the Purchaser. The bidder shall not be allowed to modify or change the conditions of the tender while extending the period of validity.

XXXII DECLARATION FROM BIDDER:

In order to ensure participation of reliable and honest bidders / contractors / vendors, etc. the bidder shall submit the declaration along with the bid in Annexure-I.

XXXIII CORRUPT OR FRAUDULENT PRACTICES:

The Maharashtra State Electricity Distribution Company Ltd. and the State require that bidders / suppliers / contractors observe the highest standard of ethics during the procurement and execution of such contracts. In pursuance of this policy, MSEDCL:

(a) defines for the purposes of this provision, the terms set forth below as follows:

- (i) "corrupt practice" means behavior on the part of officials in the public or private sectors by which they improperly and unlawfully enrich themselves and / or those close to them, or induce others to do so, by misusing the position in which they are placed, and it includes the offering, giving, receiving or soliciting of anything of value to influence the action of any such official in the procurement process or in contract execution; and
- (ii) "fraudulent practice" means a misrepresentation of facts in order to influence a procurement process or the execution of a contract to the detriment of the Employer, and includes collusive practice among bidders (prior to or after

bid submission) designed to establish bid prices at artificial non-competitive levels and to deprive the Employer of the benefits of free and open competition.

- (b) will reject a proposal for award if it determines that the bidder recommended for award has engaged in corrupt or fraudulent practices in competing for the contract in question;
- (c) will declare a firm ineligible, either indefinitely or for a stated period of time, to be awarded an MSEDCL contract if at any time it determines that the firm has engaged in corrupt or fraudulent practices in competing for, or in executing, an MSEDCL contract.

XXXIV INFLUENCE:

Any efforts by the bidders to influence the owner during evaluation process before order placement will be rejected. Similarly deviation in the term of payments, penalty, performance deposit, delivery period will be treated as non-responsive quotation/offer and will not be considered for evaluation/order placement.

Bidder shall submit the undertaking certifying that they have not approached any one for undue influence.

XXXV TENDER FEES EXEMPTION:

Tender fee to be paid at the time of uploading / online submission of the tender. Bidders from the following categories are exempted from payment of Tender fees:

- 1) All Government and semi Government institutions under Govt. of Maharashtra and Zilla Parishad in Maharashtra and fully owned undertaking of any State Govt. and Govt. of India only for the items manufactured by such institutions.
- 2) Micro and Small Enterprises registered under Micro, Small and Medium Enterprises Development Act-2006 only for the items mentioned in their permanent registration certificate at the time of vendor registration.
- 3) The bidder registered with N.S.I.C. and those who have attached valid N.S.I.C. Registration Certificate at the time of vendor registration.

The benefits mentioned in (1) to (3) above shall be available only to those items approved during the registration process and subsequent updates in registration up to the date of submission of this tender.

The tender fee paid against the particular tender shall not be refunded / transferred /adjusted at all.

XXXVI PRE-BID MEETING:

- 1) The bidder or its official representative is invited to attend pre-bid meeting (s) which will take place at the place, date and time designated in the Bidding Data.
- 2) The purpose of the pre-bid meeting(s) will be to present the salient features of the bidding documents to the bidders, including the bid submittal requirements, the Conditions of Contract (including payment terms and conditions), the technical features of the project, and to clarify issues and to answer questions on any matter that may be raised by the bidders.
- 3) The bidder is advised to visit the Site and study the bid document thoroughly, and is requested to submit any questions in writing or by E-mail, to reach the Employer not later than one week before the pre-bid meeting.

- =====
- 4) Minutes of the meetings, including the text of the questions raised and the responses given will be transmitted without delay to all the prospective bidders through the website <https://etender.mahadiscom.in/eatApp/>. Any modification of the bidding documents listed which may become necessary as a result of the pre-bid meetings shall be made by the Purchaser exclusively through the issue of an Addendum pursuant to Clause and not through the minutes of the pre-bid meetings.
 - 5) Non attendance at the pre-bid meeting will not be a cause for disqualification of a bidder. Nevertheless, senior representatives of the bidders are strongly encouraged to participate in the pre-bid meeting to help ensure that they fully understand the key concerns of the Employer and the Employer's requirements.

XXXVII CLARIFICATION ON DEVIATIONS:

The purchaser, if necessary, shall obtain clarifications on deviations within 1 or 2 working days by requesting for such information from any or all the bidders in writing, as may be necessary.

The same should be submitted online on or before the due time and date of submission of Deviation Bid. The clarification shall be opened online on due time and date of opening of Deviation Bid.

The Schedule for submission and opening of Deviation Bid shall be communicated by auto generated e-mail of the e-tender website.

CERTIFICATE:

I / We agree to supply the materials at the rates herein tendered by me / us subject to the conditions of tender and supply in Annexure 'A' of this tender which I / We have carefully read and which I / we have thoroughly understood and to which I / we agree. I / we hereby agree to keep this offer open up to the date mentioned in tender details and shall be bound by communication of acceptance dispatched within the validity period.

Seal & Signature of bidder

**SECTION-II****CONDITIONS OF SUPPLY****1) EFFECT OF CONTRACT:**

The contract shall be considered as having come in to force and shall be in operation for a period of 9 months from the date of Notification of Award. The bidder whose offer is accepted is hereinafter called “the supplier”.

2) QUALITY OF SUPPLIES:

All materials supplied shall be strictly as per specification laid down by MSEDCL and in accordance with the approved standard Guaranteed Technical Particulars (GTP), drawings and type test reports.

3) MATERIAL AND COMPONENTS:

The material and components not specifically stated in this specification but which are necessary for satisfactory operation of the equipment / items specified, shall be deemed to be included unless specifically excluded and shall be supplied without any extra cost.

4) ACCEPTANCE OF SUPPLIES / INSPECTION:

- i) The supplier shall normally offer at a time, the entire quantity required to be delivered every month as per the delivery schedule indicated at Annexure ‘B’ of A/T for the purpose of inspection by the Purchaser.

Time being the essence of contract; the supplier shall strictly maintain the monthly delivery schedule.

- ii) Materials shall be inspected by the Purchaser’s Executive Engineer / or the representative authorized by the Purchaser before dispatch. An intimation in the prescribed Proforma about the date on which materials shall be ready for inspection, indicating quantity, shall have to be given to the Executive Engineer / or the representative authorized by the Purchaser before dispatch so as to reach him 10 working days in advance, failing which, the supplier shall be responsible for delay in delivery on account of inspection.

The intimation in the prescribed proforma (Inspection call) shall be forwarded on MSEDCL Material Inspection Portal i.e. <https://mip.mahadiscom.in/InspectionPortal/>. Inspection calls sent via any other media will not be entertained and the supplier will be responsible for delay in delivery on account of inspection.

The inspection call should reach to MSEDCL maximum 7 days prior to date of readiness. On receipt of such intimation, the materials shall be inspected within 10 working days from the date of receipt of inspection call. The materials shall be dispatched only after inspection and approval of same by the Inspector. The inspection approval letter shall be valid for a period of 30 days from the date of issue of letter to enable the supplier pack the material and arrange transportation thereof so that material should be reached at the respective consignee within scheduled delivery period.

After this period of 30 days, the validity of this inspection approval letter will lapse. If the material is not reached within scheduled delivery period to respective consignees, the approval of purchaser is to be sought by the supplier for revalidation of inspection approval letter at the sole discretion of MSEDCL.

For quantity supplied beyond contractual delivery period, statutory variations is applicable only when the delayed delivery is attributed to MSEDCL.

- iii) The supplier shall notify the names of the consignees as per DI, to whom the inspected lot would be dispatched. The supplier shall get the copies of inspection approval letter together with witness certificate duly signed by the concerned Inspecting Officer and also mention reference or inspection approval letter on the challan / invoice, failing which any delay occurred in getting the S.R. Notes from the consignees would be solely to supplier's account. The inspection report shall be filled in online on the same day by the Inspector from the site on MSEDCL web portal after the inspection.
- iv) Factory address, from which the bidder has to supply the material, shall be as indicated in the latest approved on line vendor registration form on e-tendering through which the bidder has submitted the offer.
- v) The supplier shall offer inspection call intimation of readiness of material as per the monthly schedule only. In the event, during the inspection by the Purchaser's Inspecting Officer, if it is observed that the quantity actually offered for inspection is less than the quantity indicated for inspection in the inspection call, the Purchaser shall be entitled to recover from the supplier, the actual expenses incurred for arranging the inspection, and the supplier shall not dispute the amount to be recovered.
- vi) The supplier shall submit the test certificates / reports from any NABL approved laboratory or the laboratory of his own for the respective quantity of material, before dispatch. The material shall not be dispatched unless and until the test certificates are approved by the Purchaser.
- vii) All the necessary help shall be extended by the supplier to the authorized representative of the Purchaser to carry out testing of equipment / materials. Testing equipment's shall be arranged by the supplier.
- viii) MSEDCL may issue the dispatch instructions (DI) to deliver the ordered quantity to the bidders in Maharashtra within same districts of factory location of the supplier. However, it will not be binding on the MSEDCL; supplier has to deliver the material in other districts as per MSEDCL requirement. Further outside Maharashtra bidders have to deliver the material as per MSEDCL requirement to the designated consignee.
- ix) MSEDCL on its sole discretion may get material / equipment inspected and tested by third party NABL lab.

5) RIGHT TO CARRY OUT INSPECTION DURING MANUFACTURING:

The Purchaser at its option, will inspect the material ordered during its process of manufacturing including the inspection of raw materials and will request the supplier to carry out such tests as may be necessary to ensure proper quality of the material. The samples of components of the material shall be subject to quality check by the inspecting officer during manufacturing.

=====

6) RIGHT TO REVISE DESPATCH INSTRUCTIONS, DELIVERY SCHEDULE AND TO DEFER SUPPLIES:

- i) The Purchaser reserves its right to revise the dispatch instructions issued along with the order, at the time of giving final clearance for dispatch after inspection of the material. If such change in destination is not intimated at the time of inspection approval or waiver of inspection, the supplier shall dispatch the material as per the dispatch instruction in accordance with A/T. indicated by him in the inspection call letter.
- ii) The Purchaser reserves its right to change the delivery schedule of the contract either by reducing the monthly lot up to 60% of the agreed lot or by increasing the same up to 120% of the agreed lot with prior two months' notice and the Purchaser shall not be liable to pay any compensation/damages on account of such change in delivery schedule.
- iii) The Purchaser reserves its right to defer the balance supply to be received against the order by giving two months' notice for a maximum period of 6 months. In such an event, the delivery period for the deferred material shall be deemed to be extended proportionate to the period of deferment and the Purchaser shall not be liable to pay any compensation/damages on account of such deferment of deliveries.

7) WAGON LOADS / TRUCK LOADS:

Quantity to be dispatched to consignee should be minimum in two full truck loads and may be part load as per the Purchaser's requirements may not necessarily be in full wagon load / truck load and may be part load as per the Purchaser's requirement.

8) ROAD TRANSPORT:

In case the supplier prefers to dispatch the materials by road transport at his risk and cost and without any extra cost to the Purchaser, the materials shall be accepted only during office hours on working days. The supplier should ensure that the goods reach the stores in first half so as to arrange their unloading during office hours, failing which, the Purchaser shall not be liable for delay in unloading and for inconvenience caused to the transport contractor in the form of detention etc. Unloading at stores will be arranged by the consignee.

9) DESPATCH INTIMATION:

The supplier shall inform by e-mail to the consignee details of dispatch along with e-way bill receipt in hard & soft format giving RR / LR No., Wagon / Truck No., Type of wagon, craneable consignment or otherwise, total value of consignment, etc. to facilitate the consignee to arrange for clearance of goods on cemmcmsedcl@mahadiscom.in or cemmcmsedcl@gmail.com.

10) BILL OF MATERIALS: (WHEREVER APPLICABLE)

The supplier shall furnish bill of materials for each type of equipment / material offered which should be consistent with the drawing, specification and guaranteed technical particulars. The copies of the bill of materials should always be enclosed along with the bill submitted by the supplier for payment wherein he should specifically mention the materials / components dispatched out of the bill of materials, if the equipment is not sent in totality. Where the equipment / material to be supplied consist of more than one component, the supplier claiming payment for equipment / materials shall certify that all components of the equipment / material have been supplied in full for the quantity indicated in the invoice. Part payment shall not be allowed.

11)PACKING LIST:

Each package shall contain, in waterproof cover, the detailed list indicating the order reference, date, list of content and reference to the approved bill of materials. Each item contained in the package shall be described sufficiently to enable identification of the quantity, weight etc. There should not be any alteration in the packing list incorporated in the order, soft copy of the packing list should be sent to all the consignees and hard copy to G.M. (F&A-SB) should be enclosed with the bills along with other documents.

12)REPLACEMENT OF GOODS LOST, BROKEN OR DAMAGED:

Notwithstanding anything herein contained, the supplier undertakes to be responsible for the safe arrival of the materials in good condition and without any loss or damage at the final destination and until the same be actually delivered to and received by the Purchaser at its stores or other place of final destination and for this purpose, materials carried by railways or other carrier shall be deemed to be so carried at the risk of the supplier. In case of transit damage / shortages, the payment shall be made only for the quantity received in good and working condition and the consignee shall lodge claims with carriers and transfer the same to the supplier with all necessary documents for settlement of the same with carriers at the supplier's end. The transit damages / shortages / losses reported by the consignee shall be repaired / replaced by the supplier duly inspected, free of cost, within one month from the date of such intimation of breakages / shortages / losses without waiting for settlement of the claims from carrier or insurance co. etc.

However, rectification of minor defects at store locations are allowed for following minor defects only.

- i. Leakages.
- ii. Bushing replacement
- iii. LA replacement
- iv. Nut bolt tightening etc.

13)REPLACEMENT OF REJECTED MATERIALS:

If, on inspection at the final destination, the Purchaser discovers any loss in the materials supplied or that they are received in damaged condition or that in the opinion of the Purchaser, they are not of the contracted quality or specification, the Purchaser shall be entitled (notwithstanding that the property in the materials shall have passed on to the Purchaser) to refuse to accept or reject the materials altogether and claim damages or cancel the contract and buy its requirements from any of its suppliers stipulating earliest possible delivery and in accordance with its tender system against the supplier and recover the damages if any, from the supplier from any outstanding sums that may be due to the supplier from the Purchaser against this contract or against any of the contract entered into with the supplier, without prejudice to other rights and remedies available to it in law and reserving always to itself the right to forfeit the performance deposit placed by the supplier for the due fulfillment of the contract.

In case the stores / materials are found not in accordance with the prescribed specifications and / or the approved sample, the same will be rejected and the supplier shall replace the rejected stores / materials free of cost within one month from the date of intimation. The replacement of goods shall also have to be got inspected as per inspection clause. Further if the stores / equipment supplied becomes incomplete on account of either

rejection or short supply of its components, the complete cost of the stores / equipment shall be recovered from supplier's bills without notice.

14) MATERIAL DESPATCHED AND PROGRAMME:

A statement as under indicating dispatches effected during every month shall be furnished to this office along with the programme of manufacturing / dispatches during the following two months. In the event of no dispatch, the statement shall contain nil information.

MONTHLY STATEMENT:

I. Name of Supplier:

II. Reporting Month:

Sr. No.	A/T No.	Material	Item No. as Per A/T	Consignee	RR / LR Delivery Challan No. With date	Date of Actual Receipt of Material	Qty. Dispatched Between 26 th of Preceding Month and 25 th of the Reporting month	Programme of supply during the next 2 months
1	2	3	4	5	6	7	8	9

Consolidated details of the above information shall be furnished to office of the Chief Engineer (M.M. Dept.) after completing the supplies of a particular order. The copy of this consolidated information shall invariably be forwarded to the respective consignees, failing which; security deposit paid against the contract shall not be released.

15) MATERIAL RECEIPT & SUBMISSION OF BILLS AT CONSIGNEE:

On receipt of material at destination of consignee as per DI, Additional Executive Engineer (MM DEPT.) of respective store should ensure the receipt of material in good & healthy condition. While receiving the material, store in charge should ensure the receipt of material as per Dispatch Instructions issued by MM Dept. Further, the store in charge should ensure the receipt of original & scan copies of following documents:

- a) Tax invoice.
- b) Detailed packing list.
- c) Bill of Material.
- d) Delivery challan.
- e) E-way bill receipt.
- f) Dispatch document (RR/LR).

On confirmation & validity of above documents, store in charge will generate Provisional SR Note through ERP system immediately for receipt of material at stores thereof.

Where required by the Purchaser, the successful bidder must send the operation and maintenance manuals, test certificates, drawings etc. for the material ordered. These should be sent immediately after dispatch of material and a statement to that effect should be made in the invoice.

After successful RST of supplied each lot, store in charge will generate final SR note through ERP system immediately from receipt of RST report at stores.

16) PAYMENT OF BILLS:

(a) Terms of payment:

- a. The Bidder shall be paid 100% payment within 60 days from the date of receipt of material in good condition, against Stores Receipt Notes (S.R. Notes) issued by the concerned consignee.
- b. However, in respect of only those entities which qualify for 45 days payment period under the Micro, Small and Medium Enterprises Development Act, 2006, 100% payment of the Contract price will be paid within 45 days from the date of receipt of material at Consignee Store in good condition, against Stores Receipt Notes (S.R. Notes) issued by the concerned consignee.
- c. In respect of Micro, Small and Medium Enterprises, best efforts will be made for payment within 45 days from date of submission of invoice along with requisite documents after the delivery of entire lot. However, no claim for interest will be entertained in case of delay in payment beyond 45 days. The Micro, Small and Medium Enterprises who are ready to accept this payment term may only quote. No dispute in this regard will be entertained. After completion of order, the claims of whatsoever nature lodged after 30 days from the last date of payment will not be entertained.
- d. The payment shall be effected by A/C payee cheques / RTGS. Following documents as required in terms of order, will have to be forwarded to the G.M. (F&A-SB), Maharashtra State Electricity Distribution Co. Ltd., Prakashgad, Station Road, Bandra (East), Mumbai - 400 051 along with bills in triplicate to facilitate payment with a copy to the Chief Engineer of respective Zone.
 - (i) Invoice (on the basis of rates accepted as per A/T) issued in accordance with the provisions of GST Invoice Rules.
 - (ii) Inspection and Test Certificate approval.
 - (iii) E Way Bill
 - (iv) Copy of Acceptance letter of Permanent Bank Guarantee / Security Deposit Certificate.
 - (v) Packing list.
 - (vi) Approved Bill of Material.
 - (vii) Certificate of having dispatched Operation & Maintenance Manual, copies of Test Certificates and approved drawings / Bill of Material to consignees wherever applicable.

The supplier shall forward the original R.R. / L.R. direct to the consignee along with relevant documents. The original bill shall be forwarded to The G.M. (F&A-SB), MSEDCL, Prakashgad, Bandra (E) and marked ORIGINAL. The bill should indicate the GST registration no. and date held by him under the GST Law. The Purchaser shall not be responsible for delay in payment of bills if the supplier fails to comply with any of the above requirements.

Supplier's copy of S.R. Note will be forwarded by the consignees through their

respective Common Stores for supplier's record towards acknowledgement of receipt of material. Accounts copy of S.R. Note will be forwarded by the respective Common Stores to G.M. (F&A-SB) for payment.

Wherever the payment is to be effected against Material Receipt Intimation (MRI) and if the supplier fails to forward the documents such as inspection report, bill of materials, approved drawings, etc. wherever required along with the invoice to the respective consignees and no payment shall be made against the said MRI.

The whole of the first lot as well as monthly lot when delivered in installments, the date of delivery and due date of payment will be counted after the receipt of the entire lot.

Any amount more than Rs. One Lakh can be transferred to the bank Account of the supplier electronically. For this RTGS (Real Time Gross Settlement) provision, following information is to be furnished by the bidder in the required documents of the online offer.

1. Name of the Company
2. Name of the Bank & Branch with address where the amount is to be transferred.
3. Current Account Number (15 digits)
4. RTGS No. / (IFSC Code) (Indian Financial Security Code)
5. MICR Code of the Bank
6. Company's email ID
7. Contact Name & Telephone No.

17) TAXES:

(A) Notwithstanding the fact that contract price is inclusive of GST:

- (i) GST shall be paid at actual on the basis of due date of delivery or actual date of supply whichever is lower against documentary evidence.
- (ii) Variation in GST on bought out items shall not be entertained.

(B) Structural changes in and due to 'Input Tax Credit' Scheme: -

- (i) In the event of any structural change occurred in the Input Tax Credit Scheme after the date of submission of the tender till the currency of the contract, the benefit out of such change shall be passed on to the purchaser.
- (ii) In the event of 'Input Tax Credit' being extended by the GST Law which were otherwise ineligible for claiming Input tax credit thereof, the seller should advise the purchaser about the additional benefits accrued or any variation thereof, through a letter containing such details and computation within such time as may be agreed between both the parties i.e. Supplier & MSEDCL.

18) DEDUCTION:

Any amount or amounts which become payable by the supplier to the purchaser under a particular contract, shall be deducted by the purchaser from any amount/amounts due or becoming due to the supplier under the same or any other contract and shall be adjusted against dues to the Purchaser.

19) GUARANTEE:

Material offered shall be guaranteed for a period 66 months from the date of receipt at the consignee's Stores Center or 60 months from the date of commissioning, whichever is earlier. In case of failure of material within the above guarantee period, tenderer shall make available other new conditioned / repaired material / equipment, free of cost at Division / Stores for replacement within 45 days from the date of intimation from Division filter unit / Stores and lift the failed material / equipment for repair rejected material after replacement. For this purpose, bidder shall maintain spare stock in adequate quantity of ordered ratings of material / equipment. If the defective material is not replaced / repaired within the specified period as above, the Maharashtra State Electricity Distribution Company Ltd. shall retain an equivalent end cost of material plus 15% supervision charges from any of the bills of the supplier or encashing available performance bank guarantee submitted against guarantee period or through any available sources, till the return of the equipment. No interest will be paid on the amount so retained / recovered. In case of material / item not returned duly repaired within 45 days, penalty shall be imposed @ 0.5% per week or part thereof maximum up to 10% of the cost of undelivered material / equipment beyond specified time limit. In case of material / item not returned duly repaired within 5 months, total cost of the material / item along with penalty will be adjusted / recovered from the pending bills of the supplier or encashing available performance bank guarantee submitted against guarantee period or through any available sources with MSEDCL.

The guarantee period failed material / equipment will be made available at MSEDCL filter unit. Loading and unloading of guarantee period failed material / equipment should be arranged by the supplier.

The clause itself shall be the notice to the supplier about encashment of PBG to adhere to the timelines.

The outage period, i.e. the period from the date of failure till unit is repaired / replaced shall not be counted for arriving at the guarantee period. Thus supplier has to extend the guarantee period by outage period.

Further, in case of repeated failures of equipments / material, the Purchaser reserves the right to debar / disqualify the supplier for future tenders / orders.

20) LIFTING OF MATERIALS:**A) LIFTING OF REJECTED/DAMAGED MATERIALS FROM STORES:**

(a) On failure to replace or repair the transit damaged or rejected material within one month from the date of intimation as required under tender, it shall be deemed to have concluded that such material is finally rejected. The damaged / rejected material shall be lifted by the supplier within 30 days from the date of receipt of notice to that effect from the concerned consignee on reimbursement to the Purchaser of the cost of the material / equipment, if any, already paid in terms of payment clause in the contract and actual expenses incurred by the consignee towards handling, demurrage / wharfage / undercharges, freight, insurance premium etc. The Purchaser shall not be responsible in any case for the loss, destruction, damage, deterioration of the material after expiry of the said 30 days period.

(b) If the supplier fails to lift the material within this period, the material will remain with the Purchaser at the cost and risk of the supplier. Supplier shall, therefore, be liable to

pay ground rent @ 0.1% (Plus GST as may be applicable) per day of purchase cost of the material to be lifted from the date of intimation of rejection till the actual date of lifting.

- (c) The Purchaser will give 7 days' notice for lifting of rejected material and if not lifted, will be also free to Scrap / dispose of such material, after the period of said 37 days, by Public auction/Tender notice/Destruction as may be deemed fit and storage charges @ 0.1 % (Plus GST as may be applicable) per day of purchase cost will be recovered from the date of intimation of rejection of materials till the date of realization of the sale amount/physical removal of the material besides the actual expenses incurred as referred to at (a) above. The amount received from the sale of scrap/rejected material will be adjusted in the penalty.

Notwithstanding what is contended in the foregoing clauses, the supplier shall be liable to pay the Purchaser the cost and expenses incurred by the Purchaser, if any, including ground rent and the same shall be appropriated and recovered from the sale proceeds.

B) LIFTING OF FAILED MATERIAL / EQUIPMENT FROM DIVISION FILTER UNIT:

- a) If the supplier fails to lift the failed material within specified period, the material will remain with the Purchaser at the cost and risk of the supplier (By recovering end cost of failed transformer). The Purchaser will be also free to dispose of such material, after the period of 5 months from the date of intimation of failure by Public auction / Tender notice / Destruction as may be deemed fit or repaired departmentally and recovered cost will not be refunded to supplier.
- b) Process for lifting of rejected / damaged / failed materials from Divisions / Stores:
- i. The communication / correspondence shall only be made by specified e-mail id cemmcmsedcl@gmail.com by MSEDCL field offices / the supplier.
 - ii. As soon as the material/equipment is failed within guarantee period, the concerned Executive Engineer of O&M Division / Stores-in-charge shall inform the intimation of such failure immediately to Supplier as well as Material Management Department, Head Office on specified e-mail id in Format A (failure report).
 - iii. The Material Management Department will forward the format A to SB Section, Head office to withhold the payment equivalent to the cost of material/equipment with 15% supervision Charges from any of the bills of the supplier. If the supplier fails to return repaired transformer at concern O&M Division / Store within 45 days from the date of intimation, penalty to be imposed @ 0.5% per week or part thereof maximum up to 10%.
 - iv. On receipt of material/equipment against replacement or repairs, the Executive Engineer, O&M Division / Store-in-charge will issue Format C (Rectification report) to concern supplier with copy to Material Management Department Head Office through specified e-mail id.
 - v. The supplier shall note that the guarantee period for the delayed period taken for replacement / repairing of material/equipment will be automatically extended.
 - vi. Material Management Department Head Office shall inform the SB Section, Head office to release the payment withheld against that material/equipment.
 - vii. From the date of intimation, if supplier fails to return repaired material/equipment at O&M Division / concern store within 5 months, concerned Executive Engineer of O

=====

& M Division / Stores-in-charge shall inform the intimation of such failure immediately to Material Management Department, Head Office on specified e-mail id.

- viii. The Material Management Department Head Office shall forward the same to SB Section, Head office to recover the payment equivalent to the cost of material/equipment from any of the bills of the supplier with penalty to be imposed @ 0.5% per week or part thereof maximum up to 10% for final recovery as per clause 19.

21) LIQUIDATED DAMAGES FOR LATE DELIVERY:

In case the materials are not delivered within the period stipulated in the order, the supplier shall be liable to pay at the discretion of the competent authority of the Purchaser, the liquidated damages to the Purchaser @ 1% per week or part of week on the value of delayed material / unexecuted quantity plus taxes as applicable, if any on the price subject to a maximum of cumulative ceiling of 10% reckoned on the contract value of such complete portion or section of the plant, equipment or material delayed and also the portion supplied which could not be brought into commission due to any part thereof not having been delivered in time. In addition to above if bidder fails to supply the material within contractual delivery period continuously for 3 lots, then the order shall be liable for cancellation.

Due consideration may be given in the levy of liquidated damages for reasons absolutely beyond the control of the supplier, for which documentary evidence shall be produced to the satisfaction of the competent authority of the Purchaser.

The Purchaser shall be entitled to deduct/recover the amount of liquidated damages from the current bill payable to the supplier or any other amount due or payable to him against this or any other contract.

For computing the liquidated damages for delayed supplies, the date of railway receipt or the date of receipt of materials at stores in case of road transport, shall be the date of delivery.

In case the Purchaser does not arrange for inspection of material within 10 days from the date of receipt of inspection call to MSEDCL wherever applicable, the period of more than 10 days till inspection will not be considered for levy of liquidated damages. For computing the period taken for inspection in such cases, the relevant date mentioned in the inspection certificate issued by the inspecting officer would be considered.

22) ORDER PLACED ON TIME PREFERENCE BASIS (WHEREVER APPLICABLE):

In case of order on time preference basis (i.e. orders given at higher rate on delivery period considerations only) if order is given at higher rate of L-2 (or L-3 etc.), then the payment at higher rates will be made provided the firm makes supplies within the stipulated time period. In case of delay in supplies, the payment will be made at the rates offered by L-1. In addition, Clause No.21 above for Liquidated Damages for late delivery will also be applicable. However, the quantity allocation for order under this clause shall be at the sole discretion of MSEDCL & the specified quantity allocation for this tender will not be applicable in this case.

23) FORCE MAJEURE CLAUSE:

If, at any time, during the continuance of this contract the performance in whole or in part by either party of any obligation under this contract shall be prevented or delayed by reason of any war, hostility, acts of the public enemy, civil commotion, sabotage, fires, floods, explosions, epidemics, quarantine restriction, strikes, lock-outs or acts of God (herein after referred to as "events"), provided notice of happening of any such eventuality is given by either party to the other within 21 days from the date of occurrence thereof, neither party shall by reason of such

event, be entitled to terminate this contract nor shall either party have any claim for damages against the other in respect of such non-performance or delay in performance; and deliveries under the contract shall be resumed as soon as practicable after such event has come to an end or ceased to exist, and the decision of the purchasing officer as to whether the deliveries have been so resumed or not, shall be final and conclusive, provided further that if the performance in whole or part of any obligation under this contract is prevented or delayed by reason of any such event for a period exceeding 60 days, either party may at its option terminate the contract PROVIDED ALSO that if the contract is terminated under this clause, the purchaser shall be at liberty take over from the contract at a price to be fixed by the purchasing Officer which shall be final all unused, undamaged and acceptable materials, bought out components and stores in course of manufacture in the possession of the contractor at the time of such termination or such portion thereof as the purchaser may deem fit accepting such material, bought out components and stores as the contractor may with the concurrence of the purchaser elect to retain.

24)ACCEPTANCE OF LOWER FORD RATE OFFERED IN SUBSEQUENT TENDER :

During contractual delivery period of supply, the quoted rates shall remain the same, however for same specification of material if the rates will receive lower in another subsequent tender in extended period of contract then it is binding on the supplier to supply the same material at lower rate for balance quantity of material i.e. in case if price bid of next subsequent tender of similar technical specification is opened and FORD rate found lower than the ongoing contracts this FORD rate shall be made applicable for the balance quantity beyond contractual delivery period. Further the purchaser reserves the right to allow the supplier to deliver the quantity or otherwise beyond the contractual delivery period.

However other stipulations of clause No. 23 of Section-II i.e. Annexure-A will remain unchanged.

25)PERFORMANCE OF CONTRACT:

The Purchaser will not be in any way liable for non-performance either in whole or in part of any contract or for any delay in performance thereof in consequence of strikes, shortage, non-availability of raw materials, combination of labour or workmen or lockout, breakdown or accident to machinery or accidents of whatever nature, failure on the part of the railways to supply sufficient wagons to carry essential raw materials etc. and finished products from the stores, subject to the provision and stipulation made in condition No. 21 as stated above i.e. Liquidated damages for late delivery.

26)CONTRACT PERFORMANCE DEPOSIT:

- a) The supplier will have to furnish contract performance deposit as per Annexure - N in the form of unconditional & irrevocable BG within 15 days from the date of issue of LoA, as mentioned in Clause 26.2.
- b) The contract performance deposit shall be an amount equal to 5% of the contract value and shall be valid for a period of 90 days beyond guarantee period of the last lot of the equipment supplied.
- c) The contract performance deposit shall be refunded within 90 days from the date of expiry of the guarantee period of the equipment supplied. The purchaser shall not be liable to pay any interest or compensation to the contractor for retaining the deposit after the end of the said period.

- =====
- d) The contract performance deposit is intended to secure the performance of the contract for guarantee period of the equipment supplied. However, it is not to be construed as limiting the damages stipulated in other clauses of the contract.

27)POWER OF ATTORNEY:

It will be obligatory on the supplier to communicate the revocation of Power of Attorney, if any, after submission of offer till the execution of contract failing which the act/s & action done by the agent / representative shall be deemed to be the valid act/s & action of the bidder / supplier.

28)SETTLEMENT OF DISPUTE:

Permanent Dispute Resolution Committee (PDRC) comprises of Chief Engineer (MM Dept.), one member of Accounts Department and representative of supplier will resolve the dispute arise if any.

29)JURISDICTION:

Any disputes or difference arising under, out of or in connection with this tender or contract if concluded, shall be subject to the exclusive jurisdiction of the "Courts" in Mumbai.

30)TERMINATION OF CONTRACT

- 1) The decision of the Purchaser shall be final as regards the acceptability of the stores supplied by the supplier and the Purchaser shall not be required to give any reason in writing or otherwise at any time for the rejection of the stores/materials.
- 2) In case the contractor/supplier fails to deliver the stores/material or any consignment thereof within the contracted period of delivery as per delivery schedule or in case the stores/materials are found not in accordance with the prescribed specification and the performance of the supplied material is not found satisfactory, the Purchaser shall exercise in discretionary power either,
 - a) To purchase from elsewhere, after giving 15 days due notice to the contractor, at the risk of contractor, such stores/material not so delivered or other of similar description, without cancelling the contract in respect of consignment not yet due for delivery,
 - OR
 - b) To cancel the contract reserving Purchaser's right to recover damages Plus GST as may be applicable.
 - c) notwithstanding that the powers under (a) and (b) referred above are in addition to the rights and remedy available to the Purchaser under the General Law of India relating to contract.
 - d) Purchaser reserves right to recover damages against risk purchase or 10% value of non-supplied material plus applicable taxes, if any whichever is higher.

In the event of risk purchase of stores of similar description, the option of the Purchaser shall be final. In the event of action taken under (a) or (b) above, the supplier shall be liable for any loss which the Purchaser may sustain on that account but the supplier shall not be entitled to any saving on such purchases made against default.

- 3) Further contract can be terminated in case of sub-standard /poor quality material.

=====

31)DEBAR / BLACKLISTING OF MANUFACTURER:

In the event of fraudulent practices / non-compliance / non fulfillment of any obligation as required by MSEDCL at any stage of tendering or execution, the bidder is liable to be debarred / blacklisted at the discretion of MSEDCL.

32)TAX DEDUCTED AT SOURCE:

The purchaser shall deduct tax at source in accordance with the provisions of the laws as and when the same is notified.

SECTION-III

I. Quantity procurement :

The quantity for procurement is as below.

Capacity	Quantity	Estimated Cost
11/√3/0.25KV, 25 KVA single phase	- 7000 Nos.	Rs. 45.74 Crs.

II. Qualifying Requirements:

1. The bidder shall be an Original Equipment Manufacturer (OEM) and possess valid BIS license (If applicable) and BEE certificate (If applicable) as per clause no XIV.

Upload:

- a) BIS License and BEE certification.

2. The bidder should have experience for supply of similar or higher rating of material / equipment to any Electricity Distribution Utility, Electricity Distribution Franchisee or Public Sector Undertaking and should have executed orders of 30% of tender quantity for offered item during last three financial years.

Bidders who supplied the material in MSEDCLs projects viz; INFRA - II, IPDS, DDUGJY, DPDC, DDF, Non DDF, HVDS or any other scheme shall also be considered & bidder shall produce the order completion / quantity supplied certificate from concern Superintending Engineer (Infra/O&M).

Upload:

- a) Copies of orders executed by the bidder and the Certificate from the purchaser with regards to successful execution of the order / supply of quantity for preceding three financial years.

- b) List of orders in hand.

3. For all tendered material, valid Type test certificates (If applicable) as per MSEDCLs technical specifications (Annexure-D) which are carried out within 5 years prior to the date of opening of tender from NABL accredited lab such as CPRI / ERDA shall be uploaded in the bid. Bids without the Type test certificates shall not be considered for further evaluation.

Upload:

- a) Type test certificates from NABL accredited lab such as CPRI/ERDA valid for a period of five years.

4. Average Annual Turnover – The Average annual turnover of last three financial years of the bidder shall be 30% of the tender estimated cost of offered item. The bidder has to submit the annual turnover certificate of the company of last three financial years duly certified by Chartered Accountant.

Upload:

- a) Documentary evidence showing annual turnover of last 3 years, certified by Chartered Accountant for preceding three financial years. (As per attached Format-4)

- =====
5. The bidder should have in-house testing facilities for conducting acceptance & routine tests in accordance with the procedures laid down in relevant IS /IEC amended up to date.

Upload:

- a) List of in house manufacturing and testing facilities as well as quality control set up.

6. The bidder shall have ISO certification for quantity management system & environmental management system.

Upload:

- a) ISO for quantity management system.
- b) ISO for environmental management system.

7. The bidders who quoted under New Suppliers category are exempted from experience and turn over criteria. Bidder has to submit the Annexure-O regarding declaration of participation as New Supplier in the tender failing to which it will be presumed that bidder has participated in the tender as Regular Supplier. Once the Annexure-O is submitted in the offer it will not be changed at any stage of process and qualification will be done as per Annexure-O only.

Upload:

- a) Annexure-O regarding declaration of participation as New Supplier in the tender.

8. Following Documents should be submitted by the bidder along with the bid.

Upload:

- a) Documentary evidence (for e.g. Udyam Registration/NSIC/Chartered Accountant/Engineer Certificate) for manufacturing capacity to cover the quantity offered by the bidder and considering orders in hand.
- b) Certificate from Chartered Accountant for not having controlling stake in more than one entity as per attached Format-3.
- c) Annexure-F regarding declaration of legal litigations.
- d) Annexure-I regarding debar undertaking.
- e) Self-undertaking on bidders letter head for not approaching any one for undue influence as per attached Format-2.
- f) GST registration certificate.
- g) EMD receipt (Bank Guarantee or Demand Draft)
- h) Power of attorney.
- i) Certificate for No Deviation as per attached Format-5.

=====

ANNEXURE - "B"

QUANTITY, PRICE AND DELIVERY PERIOD

ANNEXURE - "B" to be submitted online against commercial bid; attached separately

=====

ANNEXURE 'C-1'

[To be submitted later on as per as per Clause XVIII (B) of Instructions]
CONFIRMATION FOR ACCEPTING ORDER BY MATCHING RATES WITH LOWEST
ACCEPTABLE BIDDER

APPLICABLE FOR INDUSTRIAL UNITS FROM MAHARASHTRA ONLY Marketing Assistance and Purchase Preference to the units from Maharashtra (refer Clause XVIII of Instructions to Bidders):-

1. In case your unit is located in Maharashtra and the
 - (a) lowest acceptable rate received against the tender is from the unit outside Maharashtra, please confirm whether you are agreeable to accept order at that lowest acceptable rate limited to 50% (fifty percent) of our requirement.
-

APPLICABLE FOR ALL BIDDERS INCLUDING THOSE ELIGIBLE UNDER THE ABOVE CLAUSES:

1. Please confirm whether you are agreeable to accept
 - (b) order at the lowest acceptable rate received against the tender.
-

[Industrial units from Maharashtra can give option under 1(b) above for balance quantity]

Note:-

1. If the bidder gives the above confirmation for the quantity less than as indicated in Clause X (iii) of the Instructions to the Bidders, then the above confirmation shall not be acceptable.
2. Bidders may confirm matching for one or more items originally tendered.
3. Any withdrawal of confirmation for order by matching rate within validity of offer will render the entire offer invalid and shall be summarily rejected and Earnest Money Deposit shall stand forfeited.
4. A bidder will not be entitled to the benefit of offers by matching rates and will not be considered for orders if his original offer is rejected on the ground of ambiguity or because of not accepting /noncompliance of the terms & conditions of the tender.
5. In the above confirmation, if the bidder indicates any rate, then the above confirmation given by the bidder will not be considered as valid.

ANNEXURE- 'D'

TECHNICAL SPECIFICATION

As Indicated in E-Tendering

ANNEXURE-E

CONSENT FOR MSEDCL STANDARD TECHNICAL SPECIFICATIONS & GTP

Not Applicable

=====

ANNEXURE-F

(On supplier's Letter Head)

I, certify that,

The business dealings with our firm / agency M/s..... and its sister concern/Director/Partner/Proprietor have no any type of legal litigation against MSEDCL is pending in any court/Forum against/by the bidder or its sister concern/Director/Partner/Proprietor.

If it is found at any stage of tendering and order execution process then as per the tender conditions our offer will be rejected and I /We don't have any objection on the same.

I hereby certify that I am duly authorized representative of M/s.----- whose name appears above my signature.

Bidders Name:

Authorized representative's signature:

Authorized representative's Name:

Seal of the company

Name and address of the Bidder

Date:

=====

ANNEXURE -G

PRICE VARIATION CLAUSE

Not Applicable

ANNEXURE - H

GUARANTEED TECHNICAL PARTICULARS

As indicated in E-Tendering GTP Parameter

=====

ANNEXURE - I

(On supplier's Letter Head)

I, certify that,

- a. The business dealings with our firm / agency M/s..... have not been debarred by any Ministry of GoI / GoM / state owned electricity distribution utility and still in force.
- b. The Directors, Proprietors, Partners, Employee(s) or owner of our firm / agency M/s..... have not been either jointly or severally guilty of malpractices in relation to its business dealings with the Government or MSEDCL during the last five years.

I hereby certify that I am duly authorized representative of M/s.----- whose name appears above my signature.

Bidders Name:

Authorized representative's signature:

Authorized representative's Name:

Seal of the company

Name and address of the Bidder

Date:

=====

ANNEXURE - J

(On MSEDCL Letter Head)

Dispatch Instructions

BY R. P. A. D. / ORD. POST /E-MAIL

(SAP CONTRACT No: -----)

To,

M/s. -----

Email: -----

Sub: Supply of ----- against A/T No. ----- dt. -----

Ref: Final Inspection Call letter No. ----- dt. -----.

(I.W. Regn. No. ----- dt. -----)

Your readiness of material letter no. dtd.....

Dear Sir,

With reference to the above, you are requested to dispatch transformers as given below:

Sr. No.	Consigned to	Meant for Circle	Meant Zone	for	Qty. in Nos.

Further, you are requested to contact concerned S.E. (O&M) Circle / E.E. (O&M) Division / Addl. E.E. (MM Section) before dispatching / unloading the above material.

This is issued without prejudice to all other terms and conditions of the order.

Yours Sincerely,

Chief Engineer (M M Dept.)

Copy f.w.cs.to: The C.E., MSEDCL, -----.

Copy to:

The G.M. (F & A – SB), MSEDCL, Mumbai.

The E.E. (IW), MSEDCL, Mumbai.

The E.E. (O & M Division), MSEDCL, -----

The Addl.E.E. (MM Section), MSEDCL, -----

=====

ANNEXURE - K

List of Stores

Sr. No.	Name of Stores	Address
1	Common Stores Ahmednagar	Nagar-Pune Road, Opp. Arti Hotel, Kedgaon, Ahmednagar.
2	Common Stores Airoli	Power House, Thane-Belapur Road, Airoli, Navi Mumbai.
3	Common Stores Akola	Major Store Babhulgaon NH No 6 Akola.
4	Common Stores Amravati	Major Store MSEDCL Power House, Mulshi Road, Amravati.
5	Common Stores Chhatrapati Sambhajinagar	MIDC Plot No. J-13, Opp. Garware Stadium, Naregaon Phata, Chikhalthana, Chhatrapati Sambhajinagar.
6	Common Stores Beed	Near 132 kV Sub-station, Idgah Nagar, Nalvandi Naka, Beed.
7	Common Stores Chandrapur	Near Vidyut Bhavan, Bagala Chaowk, Babu Peth, Chandrapur.
8	Common Stores Jalgaon	Old MIDC Area, Behind Ajanta Lawns, Ajanta Road, Aurangabad Highway, Jalgaon.
9	Common Stores Kalyan (Netivali)	MIDC Phase 1, Near Tata Power House, Kalyan - Dombivali Road.
10	Common Stores Kamptee	Maldhakka Godown, Behind Railway Station Kamate, Nagpur.
11	Common Stores Khamgaon	Manav Dharm Bld. Near 132 kV Sub-Station, Shegaon Road, Khamgaon, Dist. Buldhana.
12	Common Stores Kolhapur	Kaneri Math Road, A/P Gokulshirgaon, Tal. Karveer, Dist. Kolhapur.
13	Common Stores Kudal	Malwan Road, MIDC Pinguli-Nerur, Kudal, Sidhudurg.
14	Common Stores Latur	MIDC Plot No. P-21/P, In Front of Kirti Gold Oil Mill, Latur.
15	Common Stores Mulshi	Phursungi-Saswad Road, Near Overhead Bridge, Mulshi/ Phursungi, Dist. Pune.
16	Common Stores Nanded	Taroda Naka Main Road, Nanded.
17	Common Stores Nashik	Aringale Plot, Hanuman Nagar, Jail Road, JunaSaykheda Road, Panchak, Nasik.
18	Common Stores Dharashiv	Near MSEDCL Rest House, Tuljapur Road, Dharashiv.
19	Common Stores Palghar	Near 33/11 kV Sub-Station, MSEB Coloney, Boisar Road, Palghar.
20	Common Stores Parabhani	Old Power House Jintur Road, Parbhani.
21	Common Stores Ratnagiri	MIDC Area Mirjole, Kuwarbav, Ratnagiri.
22	Common Stores Sangli	Near Walchand Engineering College, VishramBaug, Sangli.
23	Common Stores Satara	A/P Satara, Tal. Koregaon, Dist. Satara.
24	Common Stores Solapur	Plot No P-4, MIDC Chincholi, Behind Post Office, Solapur
25	Common Stores Tumsar	Near Power House, Nakaq Dongari Road, Old Bus Stop, Tumser, Bhandara.
26	Common Stores Yavatmal	MIDC Lohara, Yavatmal.

=====

ANNEXURE - L

Format for Inspection Call Readiness of Material

Ref. No.**Date:**

To,
The CE (MMD),
Prakashgad, Bandra (E),
Mumbai - 400051.

Sub: Inspection Readiness of material against A/T No. ----- dated. ----- for
Supply of -----.

.....

1. Brief description of the material Offered for inspection:
2. Reference of drawing Approval :
3. a) Reference of approval of type test:
b) Reference of approval of balance type test (If applicable):
4. Whether it is a joint inspection with Testing SE (TQA) etc. (if applicable):
5. a) Whether Performance Deposit has been paid against the order:
b) if paid, please give details:
6. Sr. No. of the items as per A/T:
7. Total Quantity of the items Ordered:
8. Total quantity of the items inspected so far:
9. a) Quantity monthly committed in delivery schedule:
b) Lot No. for which the Quantity is offered for inspection now:
c) Due date of delivery as per A/T for offered quantity:
10. Date of readiness of Material:
11. Complete address of the factory where materials is to be inspected:
12. Name of the person to be contacted in connection with inspection & his
Office/Factory/Residence Tel. No.:
13. Staggering holiday of Factory/Office at the place of inspection:
14. a) Whether Dispatch Instructions are available (Say Yes or No):
b) Quote Letter No.:
c) Brief destination & Qty. per consignee of this present lot offered:
15. Last visit of our Inspecting Officer:
16. a) Whether the entire material is dispatched against last inspection. (Our EE[IW]
will ensure before inspection of this lot that the earlier inspected lot is already
dispatched)
b) Quantity dispatched
17. Further programme of production Quantity likely to be offered & by what date:

Authorized Signature

For (Name of the Firm).

ANNEXURE – M

BANK GUARANTEE FORMAT

EARNEST MONEY DEPOSIT BANK GUARANTEE AGAINST TENDER

B.G. No. & DATE:

The Bank of _____ (full address of Branch) hereby agree unequivocally and unconditionally to pay, at Mumbai within 48 hours, on demand in writing from the MAHARASHTRA STATE ELECTRICITY DISTRIBUTUION CO. LTD. (name of the company formerly known as M.S.E.B.) on behalf of M/s _____ (Address as per MSEDCL REGISTRATION) who have tendered and/or contracted or may tender or contract hereafter for supply of materials. Equipments or services to the MAHARASHTRA STATE ELECTRICITY DISTRIBUTUION CO. LTD. against Tender No. ----- dated ----- total value of Tender is Rs. -----

This agreement shall be valid and binding on this Bank up to and including validity (date) and shall not be terminable by notice or any change in the constitution of the Bank or the firm of contractors or any other reasons whatsoever and our liability hereunder shall not be impaired or discharged by any extension of time or variations or alternations made given conceded or agreed with or without our knowledge or consent by or between parties to the said within written contract. The validity of this Bank Guarantee will be extended by us for the further period of six months, one month prior to its present validity period at the request of MAHARASHTRA STATE ELECTRICITY DISTRIBUTUION CO. LTD.(name of the company-formerly known as M.S.E.B.).

In case of any dispute arising out or it connection with the extension or encashment of Bank Guarantee, the Courts in Mumbai will have jurisdiction.

Our liability under this Guarantee is restricted to Rs.-----/- (Rupees----- only). Our Guarantee shall remain in force until (date). Unless a suit or action to enforce a claim under the guarantee is filed against us within six months from the aforesaid date, all your rights under the said guarantee shall be forfeited and we shall be relieved and discharged from all liability there under.

Place:

Date:

Sign-----

For-----

(Banker's Rubber Seal & Bank Code No. of signatory)

Please note that:

1. The value of non-judicial stamp paper for this Bank Guarantee is Rs.200/- should be purchased in the name of Guarantor Bank.
2. The Bank Guarantee should be furnished from any Scheduled Bank/Nationalized Bank.
3. Please state the full and complete postal address of the Bank undertaken the guarantee.
4. The Bank Guarantee may be valid as per terms and condition of A.T.
5. B.G. should be submitted along with covering letter of Bank.

ANNEXURE - N

BANK GUARANTEE FORMAT

FORM OF BANK GUARANTEE FOR THE PERFORMANCE OF THE EQUIPMENT

B.G. No.& Date:

This deed of Guarantee is made thisday of.....
By.....branch having at H.O. at..... (here in after called "the Surety" which expression shall where the context so admits include its permitted assign) in favour of MAHARASHTRA STATE ELECTRICITY DISTRIBUTUION COMPANY LTD. (name of the company formerly known as M.S.E.B.) being a government company formed as per the provisions of the Maharashtra Electricity Reforms Transfer Scheme. 2005 having its registration no. U40109 MH 2005 SGC 153645 (here in after called the "Creditor" which expression shall include its permitted assigns). WHERE AS M/s. (Name of Party)..... (Postal address as per A/T) have entered into a contract to supply (Name of Material) to the MAHARASHTRA STATE ELECTRICITY DISTRIBUTUION COMPANY LTD. (Name of the Company formerly known as M.S.E.B.). vide contract No.dtd.....on the terms and conditions in the said contract. (here in after for brevity sake called "the said contract").

In accordance with terms of the said contract, the creditor has agreed to pay to M/s.....(Name of Party)..... the said sum representing the 5% of the total contract price for the Rs...../- and WHEREAS M/s. (Name of Party).....is required under the terms of contract to furnish a Bank Guarantee for Rs...../- (Rupees:.....Only) the said sum representing the 5 %price as given in the said contract.

The surety as he requests of M/s.(Name of Party).... has agreed to give this guarantee.

NOW THEREFORE THIS DEED WITNESS AS FOLLOWS:

1. In consideration of the creditor agreeing to make to the debtor at Mumbai the payment of Rs..... (Rupees.....only) being the value of 10% of the total contractprice as given in the said contract on supplying the complete material as per the contract by the debtor failing which the surety does undertake to pay to the creditor on demand such amount of amounts as the surety may be called upon to pay not exceeding in the aggregate sum of Rs./- (Rupees.....only).
2. The surety hereby guarantee to the creditor the due performance and observance by the debtor of the terms and conditions of the contract.
3. The surety also agrees that it shall not during the currency of the guarantee herein given or during the period of its execution revoke the same even by giving notice to the creditor.
4. On account of the non-fulfillment of the contractual obligation by the debtor or in case the surety or contractor do not renew this guarantee bond as herein provided, the surety will on simple demand from the creditor, pay at Mumbai the creditor, the sum of Rs.....(Rupeesonly) as indicated under clause -1 above, without demure and without the creditor to invoke any legal remedy that may be available to them to compel the surety to pay the same even if the debtor consider such demand of the creditor unjustified.
5. The surety agrees and declares that notwithstanding anything contained in Section 133 to 135 of the Indian Contract Act 1872 (IX of 1972) or any other rule of law or equity in the view of any variance in the terms of the said contract shall not operate as a discharge of

his obligations hereunder or shall any composition made by the creditor with debtor in respect of any breach of the terms and conditions of the said contract operate as a discharge of the surety's obligation and surety further expressly agrees and declares that though as between the creditor and surety, the surety shall be liable for sum payable or falling due hereunder equally with the debtor and the surety save as otherwise herein provided hereby waives all his rights which he might as guarantor be entitled to claim and enforce.

- 6. The decision of the creditor that any sum has become payable shall be final and binding on the surety.
- 7. The guarantee shall come into force on supply of material shall remain in force till the end of(date)The surety, at the request of the creditor shall extend the validity of the Bank Guarantee for a further period of 12 months, one month prior to its present validity period.
- 8. In case of any dispute arising out of or in connection with the extension or encashment of the Bank Guarantee, the courts in Mumbai will have the jurisdiction.
- 9. The guarantee herein contained shall not be effected, by the change in the constitution of the surety or the debtor.
- 10. Our liability under this guarantee is restricted to Rs.(Rupees.....only) and our guarantee shall remain in force until (Date....) unless a claim under this guarantee is lodged with us within six months from the date of expiry of guarantee i.e. on or before ..(date)...all your rights under this guarantee shall be forfeited and we shall be relieved and discharged from all our liabilities there under.

IN WITNESS WHERE OF THE surety has executed this deed in presence of

Place: Signature.....

Date: for.....

(Banker's Rubber Seal & Code No. of signatory)

Witnessed (2 witness is required from bank only)

1) Name & Address

Signature

2) Name & Address

Signature

Please Note:

- 1. The value of non-judicial stamp paper for this bank guarantee is Rs. 200/- should be purchased in the name of Guaranteed Bank.
- 2. The bank guarantee should be furnished from any Scheduled bank
- 3. Please state the full and complete postal address of the bank undertaking the guarantee.
- 4. B.G. may be valid as per terms of A/T including guarantee period of material.
- 5. B.G. should be submitted along with covering letter of Bank.

=====

ANNEXURE-O

(On bidders' letter head)

CONSENT FOR PARTICIPATION IN TENDER AS NEW SUPPLIER

I/We, have understood and checked the tender documents for supply of -----
----- and have not found any errors in them.

I/We hereby declare and confirm that we are participating in the tender no.....as New
Supplier / Regular Supplier for particular rating as specified in the following table and agree to
supply the material as per terms and conditions of the said tender.

Sr. No.	Item Description	Regular Supplier (Yes/No)	New Supplier (Yes/No)
1	-----		
2	-----		

Note: 1) Bidder has to provide only one "Yes or No" against particular rating.

2) If for any particular rating bidder has given the option "Yes" for both the types (Regular & New Suppliers) then option for "Regular Supplier" will be considered and evaluation will be carried out as per Regular Suppliers criteria only.

3) If for any particular rating bidder has given the option "No" for both the types (Regular & New Suppliers) then it will be presumed that bidder has not quoted for that particular rating.

Yours faithfully,

Signature & Seal of company,

In the capacity of duly authorized to sign bids for and on behalf of

Address:

=====

FORMAT 1

ANNEXURE – U-I
“INDEMNITY BOND”

UNDERTAKING TO BE SUBMITTED BY THE PARENT COMPANY SITUATED ABROAD IN CASE OF THE PARTICIPANT BIDDER WHO IS AN INDIAN BASED SUBSIDIARY ON GENERAL STAMP OF `200.00.

The Chief Engineer,
 Maharashtra State Electricity Distribution Co. Ltd.,
 Material Management Department,
 1st Floor, Prakashgad, Bandra (E),
 Mumbai – 400 056.

Dear Sir:

Sub: Undertaking against Tender No. ____ for procurement of _____

We, M/s. _____ having registered office at _____ are the Parent Company of M/s. _____ who have participated against your tender no. ____ for procurement of ____.

We have carefully read and have thoroughly understood and agree to the terms and conditions of the subject tender.

We hereby undertake that in case of placement of order against the subject tender on our subsidiary company, M/s. _____, in the event of we accept all the responsibilities and liabilities for supply of quality equipments as per specification of the tender and execution of the contract. We further hereby undertake that we shall be responsible for any liability arising out of the contract placed on M/s. _____ and to pay MSEDCL on demand the sum of rupees as per agreement in the event of any breach of condition of the purchase order, loss and damage of the material till expiry of guarantee period as stipulated in the order.

Our liability here under shall not be impaired or discharged by extension of time or variation or alteration made with or without our knowledge or consent by or between the parties to the said contract. This undertaking shall be valid and binding on us upto and including the execution and guarantee period of the order and shall not be terminable by notice or change in the constitution of any of the companies. In case of any dispute arising out of or in connection with this tender or contract, if concluded, the same shall be subject to the exclusive jurisdiction of the **“Court in Mumbai (India).”**

Yours faithfully,

(Authorised Signatory)
 For _____

=====

FORMAT-2

Undertaking for not approached any one for undue influence.

(To be submitted on letter head of the bidder)

Tender No. MMD/T-..... for supply of

TO WHOM SO EVER IT MAY CONCEREN

I / We _____ hereby submit the undertaking that our firm or our partners or directors have not approached any one for undue influence against the Tender/Bid.

If it is found that we have given wrong or misleading information then our offer shall be summarily rejected.

Date:

Place:

(Signature, Name of Authorized Representative
& Company Seal)

=====

FORMAT-3

Format of Certificate from Chartered Accountant for not have controlling stake in more than one entity applied for the Tender/Bid.

(To be submitted on Letter Head of the Chartered Accountant)

Tender No. MMD/T-..... for supply of

TO WHOM SO EVER IT MAY CONCEREN

I _____ hereby certify that the firm M/s _____ or its partners or directors does not have controlling stake in more than one entity applied for the Tender/Bid.

If it is found that they have given wrong or misleading information then their offer shall be summarily rejected.

Date:

Place:

(Seal, Signature & Name of C.A.with Regn. No. & UDIN No.)

=====

FORMAT-4

Format of Certificate from Chartered Accountant for Average Annual Turnover
(To be submitted on Letter Head of the Chartered Accountant)

Tender No. MMD/T-..... for supply of

TO WHOM SO EVER IT MAY CONCEREN

We have examined the audited financials of M/s _____, having its registered office at _____, for the financial years. Based on our examination, we hereby certify that Annual Turnover for respective financial year mentioned below is in accordance with the audited financial statements:

Financial Year	Assessment Year	Annual Turnover Amount In Rupees Lakhs.
Total. Rs.		
(Rs.Figure in words)		
Average Annual Turnover Of Last Three Financial Years		

This certificate is given on the basis of copy of audited financial reports for profit/loss account and balance sheet.

Date:

Place:

(Seal, Signature & Name of C.A. with Regn. No. & UDIN No.)

=====

FORMAT-5
Format for No Deviation Form
(To be submitted on letter head of the bidder)

Tender No. MMD/T-..... for supply of

CERTIFICATE FOR NO DEVIATION

We, (Bidder's Name), hereby certify that there is no technical or commercial deviation from the Conditions mentioned in Tender Document and I am agreeing to all the terms and conditions mentioned in the Tender Specification.

Bidders Name:
Authorized representative's signature:
Authorized representative's Name:
Seal of the company
Name and address of the Bidder
Date:

Annexure 'B'(Price Schedule)

Sr.No	Item Code	Material Description	Unit	Quantity Required	HSN	Quantity Offered	Unit ExWorks including packaging charges but excluding duties & taxes etc (In Rupees)	Freight Charges Per Unit (In Rupees)	Transit Insurance Charge s Per Unit (In Rupees)	Integrated GST for outside State Transaction on (Ex-Works Price+Freight Charges + Transit Insurance Charges)(In Rupees)	Central GST for within State Transaction on (Ex-Works Price + Freight Charges + Transit Insurance Charges)(In Rupees)	State GST for within State Transaction on (Ex-Works Price + Freight Charges + Transit Insurance Charges)(In Rupees)	Free Door Delivery Price Per Unit by Road upto Destination/Stores/Sub Station (In Rupees)
1	2	3	4	5	6	7	8	9	10	11	12	13	14=(8+9+10+11+12+13)
1	20114011663	25KVA11/R3/ 250V1PHDTE EL-1 WO	NO	7000	85042100								

Delivery Details

[Delivery must in the units specified for the items as per Price Schedule]

First lot of ___ in assorted sizes will be delivered within 2 Months from the date of LOA Award. After this period supply will be completed at the rate of ___ in assorted sized per month

Confirmation Details

We Confirm The Following :

I) Goods and Services Tax(GST) i.e Integrated GST / (Central GST+ State GST):

The GST is included in our prices quoted in price bid (Central GST+ State GST) for within Maharashtra State/Integrated GST for outside State and we shall not charge any additional amount towards Integrated GST / (Central GST+ State GST), during currency of contract except statutory variation by Central / State Government in normal (full) rate of Integrated GST / (Central GST+ State GST), in case of Integrated GST / (Central GST+ State GST) Rate is increased. In case the Integrated GST / (Central GST+ State GST) is decreased than the rate indicated in the price bid, the benefits of the reduction in the Integrated GST / (Central GST+ State GST) shall be passed on to the Purchaser. The increase in the Integrated GST / (Central GST+ State GST) rate due to increase in turnover during the contractual delivery period shall not be charged to the Purchaser. If the Integrated GST / (Central GST+ State GST) is not payable at present, we shall not charge the same, if it becomes applicable during the currency of contract due to expiry / withdrawal of tax concessions and incentives during the currency of contract except for statutory variation by Central / State Government.

(i) Necessary documentary evidence for the GST claimed by us shall be submitted along with the bills.

(ii) We here by declare that while quoting the price in the Price Bid, we have taken into account the entire credit on inputs available under the GST Act.

Technical Specification Item: 25KVA11/R3/250V1PHDTEEL-1 WO CSP



Maharashtra State Electricity Distribution Company Limited

SPECIFICATION NO.MMC: MSC/DB/01 /2018

TECHNICAL SPECIFICATION

For

25KVA11/R3/250V1PHDTEEL-1 WO CSP

For

DISTRIBUTION SYSTEM

IN

MSEDCL

TECHNICAL SPECIFICATION OF SINGLE PHASE, 25 KVA , 11/ $\sqrt{3}$ /0.25kV OUTDOOR TYPE DISTRIBUTION TRANSFORMER (EEL-1) WITHOUT CSP FEATURE.

MATERIAL SPECIFICATIONS CELL

TECHNICAL SPECIFICATION

25 KVA, 11/ $\sqrt{3}$ /0.25KV, SINGLE PHASE
OUTDOOR TYPE DISTRIBUTION TRANSFORMER (EEL-1)
WITHOUT CSP FEATURE.

TECHNICAL SPECIFICATION OF SINGLE PHASE, 25 KVA , $11/\sqrt{3}$ /0.25kV OUTDOOR TYPE DISTRIBUTION TRANSFORMER (EEL-1) WITHOUT CSP FEATURE.

INDEX

1.00	Scope
2.00	Service conditions
3.00	Applicable standards
4.00	System Particulars
5.00	Design & construction
6.00	Heat Dissipation
7.00	Efficiency
8.00	Total Minimum Oil Volume
9.00	Surface protection
10.00	Cleaning and Painting
11.00	Terminal Marking Plates and Rating Plates
12.00	Tank base channel
13.00	Pressure release device
14.00	Protection
15.00	Lightening Arrestors
16.00	Fittings
17.00	Fasteners
18.00	Transformer Oil
19.00	Oil leakage test
20.00	Test and Inspection
21.00	Drawings
22.00	Rejection
23.00	Guaranteed Technical Particulars
24.00	Testing facility
25.00	Submission Routine Test Certificate
26.00	Instruction and operation Manual
27.00	Stage Inspection
28.00	Final Inspection
29.00	Random Sample Testing (RST)
30.00	Inspection & Testing of Transformer Oil
31.00	Loading of transformer
32.00	Quality Assurance
33.00	Qualifying Requirement
34.00	Performance Guarantee
	Annexure I
	Annexure II
	Annexure-III
	Annexure - "B"
	Annexure - "A"

TECHNICAL SPECIFICATION OF SINGLE PHASE, 25 KVA, $11/\sqrt{3}/0.25\text{kV}$ OUTDOOR TYPE DISTRIBUTION TRANSFORMER (EEL-1) WITHOUT CSP FEATURE.

1.00 Scope:

- 1.01 This specification covers design, manufacturing, testing and delivery of the **Single phase, 25 kVA, $11/\sqrt{3}/0.25\text{kV}$, 50 Hz, Outdoor type, Oil Natural Air Natural (ONAN) without Completely Self Protected feature, (EEL-1), Distribution Transformers.**
- 1.02 The equipment offered shall be complete with all parts necessary for their effective and trouble-free operation. Such parts will be deemed to be within the scope of the supply irrespective of whether they are specifically indicated in the commercial order or not.
- 1.03 It is not the intent to specify herein complete details of design and construction. The equipment offered shall conform to the relevant standards and be of high quality, sturdy, robust and of good design and workmanship complete in all respects and capable to perform continuous and satisfactory operations in the actual service conditions at site and shall have sufficiently long life in service as per statutory requirements.
- 1.04 The design and constructional aspects of materials shall not withstanding any anomalies, discrepancies, omissions, in-completeness, etc. in these specifications and will be subject to good engineering practice in conformity with the required quality of the product, and to such tolerances, allowances and requirements for clearances etc. as are necessary by virtue of various stipulations in that respect in the relevant Indian Standards, IEC standards, I.E. Rules, Electricity Act 2003 and other statutory provisions.
- 1.05 The Bidder/supplier shall bind himself to abide by these considerations to the entire satisfaction of the purchaser and will be required to adjust such details at no extra cost to the purchaser over and above the tendered rates and prices.
- 1.06 Tolerances:

Tolerances on all the dimensions shall be in accordance with provisions made in the relevant Indian/International standards and in these specifications. Otherwise the same will be governed by good engineering practice in conformity with required quality of the product.

2.00 Service conditions:

- 2.01 Equipment supplied against the specification shall be suitable for satisfactory operation under the following tropical conditions:-
- | | | |
|--|---|-------------|
| i. Max. ambient air temperature | : | 50 °C |
| ii. Max. relative humidity | : | 100 % |
| iii. Max. annual rainfall | : | 1450 mm |
| iv. Max. wind pressure | : | 150 kg/sq.m |
| v. Max. altitude above mean sea level | : | 1000 mtrs. |
| vi. Isoceraunic level (days /year) | : | 50 |
| vii. Seismic level (Horizontal acceleration | : | 0.3 g. |
| viii. Reference Ambient Temperature for temperature rise | : | 50 °C |

Note: Climatic Condition Moderately hot and humid tropical climate conducive to rust and fungus growth.

- 2.02 The climatic conditions are prone to wide variations in ambient conditions and hence the equipment shall be of suitable design to work satisfactorily under these conditions.

TECHNICAL SPECIFICATION OF SINGLE PHASE, 25 KVA , 11/√3/0.25kV OUTDOOR TYPE DISTRIBUTION TRANSFORMER (EEL-1) WITHOUT CSP FEATURE.

- 2.03 The equipment shall be for use in moderately hot and humid tropical climate conducive to rust and fungus growth.
- 2.04 Distribution Transformer shall be marked with the Standard Mark (ISI mark) [clause no. 13.4 of IS 1180(Part 1):2014].
- 2.05 The Single Phase Distribution Transformer shall bear (EEL-1), rating Label approved by BIS.
- 2.06 The Bidder/ Manufacturer shall possess the valid BIS license for offered product.

3.00 Applicable standards:-

- 3.01 The design, manufacture and performance of the equipment shall comply with all currently applicable statutes, regulations and safety codes. Nothing in this specification shall be construed to relieve the bidder off his responsibilities.
- 3.02 The Distribution Transformers shall conform to IS: 1180 (Part 1) : 2014 amended up to date as amended up to date or other International Standards for equal or better performance. Unless otherwise modified in this specification the Distribution Transformers shall comply with the Indian Standard Specification IS 1180 latest.
- 3.03 Unless otherwise specified, the equipment offered shall conform to amended up to date Indian, IEC, British or U.S.A. Standards and in particular, to the following:-
- 3.04 The applicable standards are as follows :

Sr.No.	IS/IEC number	Particulars
1.	IS:1180(Part-1) : 2014 Ammended up to date	Outdoor type oil immersed distribution transformers up to and including 2500 kVA, 33KV
2.	IS:2026(Part I to IV)	Specification for power transformer
3.	IS:335/1993	New insulating oil- Specification (fourth revision)
4.	IEC 60137:2017 latest amendment, IS: 7421-1988, IS:3347 (Part-I /Sec-2)-1979, IS:3347 (Part-I /Sec-1)-1982 amended up to date	Bushing
5.	IS 5	Colours for ready mixed paints and enamels.
6.	IS 13730 (Part-27)1996	Specification for particular types of winding wires.
7.	IS: 3073/1974, IS: 3070 (Part-II)	Specifications for L.A's
8.	CBIP Publication No.295:2006	Manual on transformers
9.	I.S. 13947/I/1993	Specification for low voltage switchgear & control gear
10.	IS 2026,Part-7	Guide for loading of oil immersed transformer.

TECHNICAL SPECIFICATION OF SINGLE PHASE, 25 KVA, $11/\sqrt{3}/0.25\text{kV}$ OUTDOOR TYPE DISTRIBUTION TRANSFORMER (EEL-1) WITHOUT CSP FEATURE.

3.05 In case of conflict arising out due to variations between the applicable standard and the standards specified herein the provisions of this specification should prevail.

4.00 System Particulars:-

The transformers shall be suitable for outdoor installation with following system particulars and they should be suitable for service under fluctuations in supply voltage as permissible under Indian Electricity Rules

4.01	Nominal System Voltage (HV)	: 11 KV
4.02	Rated Voltage (HV)	: $11 / \sqrt{3}$ kV
4.03	Rated Voltage (LV)	: 250 V
4.04	Rated Current (HV)	: 3.94 Amp (for 11 KV)
4.05	Corresponding Highest System Voltage	: $12 / \sqrt{3}$ kV
4.06	Neutral Earthing	: Solidly earthed at both HV & LV
4.07	Frequency	: 50 Hz with ± 3 %tolerance
4.08	Number of Phase	: 1(single)
4.09	Type of cooling	: ONAN.

4.10 Temperature Rise:

- The temperature rise for top oil over an ambient temperature of 50°C should be 35°C maximum measured by thermometer in accordance with IS 1180(Part I):2014.
- Temperature rise for winding over an ambient temperature of 50°C should be 40°C maximum measured by resistance method in accordance with IS 1180(Part I):2014.

Bids not conforming to the above limits of temperature rise will be treated as non-responsive.

4.11 No load voltage ratio:-

The no load voltage ratio shall be $11 / \sqrt{3}$ KV /250 Volts.

4.12 Flux density:-

- Flux density should not be more than **1.69 Tesla** at the rated voltage and frequency. The value of the flux density allowed in the design shall be clearly stated in the offer. The maximum flux density in any part of the core and yoke at rated voltage and frequency shall be such that the flux density with 112.5 % combined voltage and frequency variation with rated voltage and frequency does not exceed **1.9 Tesla**.
- Transformer core should be designed in such a way that it will not get saturated for any value of V/f (Voltage/frequency) ratio to the extent of 112.5% of rated value of V/f ratio (i.e. $11000 / \sqrt{3}/50$)(due to combined effect of voltage and frequency) up to 12.5% without injurious heating at full load conditions. Actual core design along with calculations in support of it should be enclosed with the offer.
- The no load current transformer shall not exceed 3% the full load current and will be measured by energizing the transformer at rated voltage and frequency. Increase of 12.5 percent of rated voltage shall not increase the no load current by 6% maximum of full load current.

TECHNICAL SPECIFICATION OF SINGLE PHASE, 25 KVA , 11/√3/0.25kV OUTDOOR TYPE DISTRIBUTION TRANSFORMER (EEL-1) WITHOUT CSP FEATURE.

25kVA	At Rated Voltage	At 112.5 % Rated Voltage
	3 % of the full load current in LT winding	6 % of the full load Current

ii. Number of steps of core shall be minimum of

	Stack core	Wound core CRGO
25 kVA	5 standard steps	One step

Only those bidders who directly imported CRGO either from the manufacturer or through their accredited marketing organization of reputed (and not through any agent) shall be considered. Only Prime quality and ISI marked CRGO core shall be used for the transformers and Test reports for specific loss, chemical analysis, surface insulation resistance shall be confirmed/ checked by inspector at the time of inspection.

4.13 Losses:

The total losses at 50% & 100% loading for Single phase, 25 kVA, 11/√3 /0.250 kV (EEL- 1), transformers at rated voltage, frequency and at 75°C shall not exceed the values indicated as below:

TABLE - 1

Max. Total losses of Single Phase Transformer in watts up to 11 kV Class			
Rating (kVA)	Impedance (Percent)	EEL- 1	
		50 % Load	100 % Load
25	4.0	110	300

No positive tolerance shall be allowed on the total losses given in the above table for both 50 % & 100 % loading values. In case the actual total loss values exceed the above guaranteed values, the transformers shall be rejected at the risk, cost and responsibility of the supplier.

The values guaranteed in G.T.P. for flux density, no load current at rated voltage, no load current at 112.5% of rated voltage and no load loss at rated voltage shall be individually met.

4.14 Insulation material & clearances:

- i) **Materials** – Makes of Electrical grade insulating craft paper, Press Board, Perma wood/Haldi wood insulation shall be declared in GTP by the bidder. The test reports for all properties as per relevant I.S. amended up to date shall be submitted during inspection.

TECHNICAL SPECIFICATION OF SINGLE PHASE, 25 KVA , $11/\sqrt{3}$ /0.25kV OUTDOOR TYPE DISTRIBUTION TRANSFORMER (EEL-1) WITHOUT CSP FEATURE.

ii) The electrical clearance between the winding and body of the tank (between inside surface of the tank and outside edge of the windings) should be minimum 25 mm for $11/\sqrt{3}$ kV class.

iii. **Minimum external clearances of bushing terminals**

		11 kV
HV	Ph to E	140 mm
LV	Ph to E	40 mm.

4.15 Impedance Value-

The percentage impedance at 75°C shall be 4% for $11/\sqrt{3}$ kV class (Tolerance of ± 10 % is applicable as per IS 2026, Part - I).

Bids not conforming to the limits indicated above will be treated as non-responsive.

5.00 Design & construction:

5.01 Core

i) For Stack Core:

The core shall be stacked core type construction using new and high grade cold rolled grain oriented (CRGO) annealed steel metal core with heat resistant insulating coating, having low loss and good grain properties, coated with hot oil proof insulation, bolted together to the frames firmly to prevent vibration or noise. All core clamping bolts shall be effectively insulated. The complete design of core must ensure permanency of the core losses with continuous working of the transformers. The core shall be properly stress relieved by annealing in inert atmosphere. The core material shall not be brittle in case of CRGO material but shall be made of prime grade (M-4 or better).

ii) For Wound core :-

The core shall be 'C' type construction of high grade cold rolled grain oriented (CRGO) annealed steel lamination having low loss and good grain properties, coated with hot oil proof insulation material. The complete design of core must ensure permanency of the core losses with continuous working of the transformers. The core material shall not be brittle in case of CRGO material but shall be made of prime grade (M-4 or better).

5.02 Core clamping for CRGO Wound core type transformers shall be as follows:

- Core clamping shall be with top and bottom U- shaped core clamps made of sheet steel clamped
- M.S. core clamps shall be painted with varnish or oil-resistant paint.
- Suitable provision shall be made in the bottom core clamp / bottom plate of the transformer to arrest movement of the active part.

TECHNICAL SPECIFICATION OF SINGLE PHASE, 25 KVA , $11/\sqrt{3}/0.25\text{kV}$ OUTDOOR TYPE DISTRIBUTION TRANSFORMER (EEL-1) WITHOUT CSP FEATURE.

The successful bidder, shall be required to submit the manufacturer's test report showing the Watt Loss per kg and the thickness of the core lamination, to ascertain the quality of Core materials. The purchaser reserves the right to get sample of the core material tested at any Government recognized laboratory.

5.03 Winding.

HV and LV windings shall be Aluminum conductors with DPC / Polyesterimide enamel (Class F) for strip conductors as per Part-16 of IS 13730 and modified polyester enamel (Class B) for round conductors as per Part- 45 of IS 13730 insulation. For transformers of 11kV voltage level Aluminum conductor and 22kV voltage level transformers copper conductors shall be used. The windings shall be progressively wound in LV, HV coil design for better voltage regulation and mechanical strength. The inner layer insulation shall be of Epoxy dotted paper.

The type of winding shall be indicated in the tender GTP. Winding must be done in cleanest possible atmosphere to prevent possible accumulation of dust particles. The coil shall be further processed for dimensional control, improved bonding and for improving short circuit withstand capability.

The current density of the **Aluminum** winding shall not be more than **1.6 A/mm²**. Test reports for material characteristics like density, tensile strength, and elongation moisture content, ash content, dielectric strength, thickness of resin etc. for epoxy dotted paper shall be submitted during stage inspection.

5.04 Winding connection & terminal arrangements:

For HV live end should brought out through 12 kV bushing and the other end of HV, which is intending to be earth, shall be brought out in 1kV bushing (HV neutral bushing) provision shall be made for connecting the neutral HV terminal to local earth.

The secondary (LV) winding shall be connected LV bushings. The HV bushing (live) shall be provided on top cover and the LV bushing shall be provided on the sidewall of the tank and below top cover.

5.05 Bushing terminals:

HV terminal connector shall be designed to directly receive ACSR/AAAC conductor upto 7/2.59 mm (without requiring the use of lug) and the LV terminals connectors shall be suitable for directly receiving LT cables (Aluminum) ranging from 50 Sq.mm to 70 Sq.mm both in vertical and horizontal position and the arrangements should be such as to avoid bimetallic corrosion. Terminal connectors must have type tested as per IS:5561.

- i) Brass rods 12 mm. dia. for HT with necessary nuts, check-nuts and plain thick tinned washer.
- ii) Tinned copper Rods of 12 mm diameter for LT extension with suitable cable lugs, necessary nuts, check-nuts and plain thick tinned washer.

5.06 Bushings & Connections:

- i) For HV $11/\sqrt{3}$ kV, class 12 kV bushing shall be used; for earth / neutral of HV winding and for LV 1 kV class bushing shall be used. Neutral end of HV winding shall be brought out to Neutral through 1KV bushing. Neutral terminal shall be connected to tank by a tinned copper strip of adequate size. Bushings with plain shade shall be as per relevant IS 1180 Part 1: 2014 amended up to date.

TECHNICAL SPECIFICATION OF SINGLE PHASE, 25 KVA, $11/\sqrt{3}/0.25$ kv OUTDOOR TYPE DISTRIBUTION TRANSFORMER (EEL-1) WITHOUT CSP FEATURE.

- ii) HV bushings shall be fixed to the top cover of the transformer tank & LV bushings of 1KV class shall be fixed to the side of the transformer tank.
- iii) Bushings having type tested, as per relevant IS (IS 3347) amended up to date shall only be acceptable.
- iv) The minimum Creepage distance for all the bushings shall not be less than 25 mm per kV.
- v) The HV bushings shall have Bird guard (Porcelain or other insulating material).
- vi) The terminal arrangement shall not require a separate oil chamber.

5.07 Tank.

The transformer tank shall be of robust construction **cylindrical** in shape and shall be built up of tested CRCA/MS sheet of the following thickness.

- i) Side wall thickness : 2.0 mm(min.)
 - ii) Top cover : 2.5 mm(min.)
 - iii) Bottom Cover : 2.5 mm(min.)
- i) The construction of the tank should be sealed and oil insulated.
 - ii) All joints of tank and fittings should be oil tight and no bulging shall occur during service. The tank design shall be such that the core and windings can be lifted freely. The tank plates shall be of such strength that the complete transformer when filled with oil may be lifted bodily by means of the lifting lugs provided.
 - iii) Only one vertical joint will be allowed in round shape tank. In addition the cover of the main tank shall be provided with an air release plug.
 - iv) The tank without oil is subjected to an air pressure of 100Kpa above atmosphere for 30 minutes and 760mm of mercury for 30 min in vacuum as per **IS 1180 part1:2014**. Permanent deflection should not be more than the limits specified in **IS 1180 part 1:2014**. Pressure test shall be performed carefully at the time of 1st stage inspection only to confirm the adequacy of the tank strength and to be certified by E.E. (Testing).
 - The long seam joint and other welds shall be oil tight and no deflection /bulging should occur during service.
 - Manufacturer should carry out the all welding operations as per the relevant ASME standards and submit a copy of the welding procedure qualifications and welder performance qualification certificates to the purchaser.
 - The bottom of the tank should be 25 mm above the transformer bottom and welded with channel.
 - Tank shall have permanent 2 Nos. lugs of 5 mm thickness for lifting the transformer bodily and there shall be facilities for lifting the core coil assembly separately.
 - The transformer tank and the top cover shall be designed in such a manner as to leave no external pockets in which water can lodge.
 - The transformer shall be provided with two mounting lugs suitable for fixing the transformer to a single pole by means of 2 bolts of 20 mm diameter as per IS 1180 Part 1 : 2014
 - Both mounting lugs are made with steel of min. 5 mm thickness.

TECHNICAL SPECIFICATION OF SINGLE PHASE, 25 KVA , 11/√3/0.25kV OUTDOOR TYPE DISTRIBUTION TRANSFORMER (EEL-1) WITHOUT CSP FEATURE.

- Minimum oil level mark shall be embossed inside the tank.
- Jump proof lips shall be provided for upper mounting lug.
- Mounting lugs faces shall be in one plane.
- The top cover shall be fixed to the tank by proper arrangement to avoid ingress of moisture.
- Design of top cover shall be such that no water can lodge on the topside.
- HV bushing pocket shall be embossed to topside of the top cover so as to eliminate ingress of moisture and water.
- The edges of the top cover shall be formed, so as to cover the top end of the tank and gasket.
- Nitrile / neoprene rubber gaskets conforming to latest Type III as per IS 11149 / Type C as per IS 4253 part-II shall be provided between tank and top cover.

The oil volume inside the tank shall be such that even under the extreme operating conditions, the pressure generated inside the tank does not exceed 0.4kg/Sq.cm positive or negative. There must be sufficient space from the core to the top cover to take care of oil expansion.

The tank cover shall have plasticized surface at the top to guard against bird-faults. Alternatively, suitable insulating shrouds shall be provided on the bushing terminals.

v) Tank sealing:

The space on the top of the oil shall be filled with dry air or nitrogen. The dry air or nitrogen plus oil volume inside the tank shall be such that even under extreme operating conditions, the pressure generated inside the tank does not exceed 0.4kg/sq.cm positive or negative. The nitrogen shall conform to commercial grade of the relevant standard.

All welding operations to be carried out by MIG process.

QR Code laminated P touch labels shall be fixed on transformer tank body below the name plate depicting various technical details such as name of manufacturer , rating , Sr.no, date of manufacturing, A/T No etc. As per annexure.

6.00 Heat Dissipation:

The manufacturer will have to design the tank such that heat is dissipated without radiators. Transformers with radiators will not be accepted. The heat dissipation by tank wall should be increased to appropriate value considering the climatic temperature rise

Heat Dissipation calculations shall have to be submitted along with the offer.

Heat Dissipation Calculation covers that the heat dissipation by tank walls excluding top & bottom should be 500 Watts/ Sq.Meter.

Heat dissipation calculation should be based on maximum measured total loss (No load loss at rated excitation + Load loss at 100% loading converted to 75°C reference temperature) shall be supplied during temperature rise test.

6.01 Efficiency:

The efficiency is the ratio of output in KW to the input in KW.

$$\text{Efficiency} = \frac{\text{Input in KW} - \text{Losses in KW}}{\text{Input in KW}}$$

TECHNICAL SPECIFICATION OF SINGLE PHASE, 25 KVA , $11/\sqrt{3}$ /0.25kV OUTDOOR TYPE DISTRIBUTION TRANSFORMER (EEL-1) WITHOUT CSP FEATURE.
7.00 Total Minimum Oil Volume:

The insulating oil shall comply with the requirements of IS 335/1993. Oil shall be filled under vacuum only.

KVA rating	Minimum Oil in liters (exclusive of oil absorbed in core & coil assembly)
25 KVA	50

8.00 Surface protection.

The transformer tanks should be powder coated, with Pale cream colour paint (shade: 352 As per IS 5). Steel surface of the tank shall be prepared by sand / shot blast or chemical cleaning including phosphate as per IS 3618. Heat resistance paint (Hot oil proof) shall be provided to the tank. On external surface one coat of thermosetting powder paint or one coat of epoxy primer followed by two coats of polyurethane base paint shall be used. Paint scheme shall be as per clause 15.5 and Table 12 of IS 1180 (Part 1):2014.

9.00 Cleaning and Painting.

- i. The external surface of transformers shall be painted with one coat of Epoxy primer (30 micron) and two coats of Polyurethane (finish coat) Liquid paint (each 25 micron) and inside surface of the tank hot oil resistant paint/ varnish with one coat with dry film thickness as mentioned in Table 12 , Cl.no.15.5 of IS 1180(Part 1):2014 . The colour of transformer shall be Pale cream colour (shade No. 352 as per IS 5).
- ii. The test of measurement of paint thickness shall be carried out cross hatch test, chemical test and other as per IS 13871:1993.
- iii. The month and year of supply shall be painted in red bold Marathi lettering at two places one at conservator and other at sum conspicuous place on the transformer which shall be clearly visible from the ground.

10.00 Terminal Marking Plates and Rating Plates:

- a) All Transformer HV terminals shall be provided terminal marking plated to Tank. Each terminal, including with neutral, shall be distinctly marked on both primary & secondary in accordance with the connection diagram fixed upon the transformer which shall conformed to latest 1S-2026 (part- IV).
- b) Each Transformer shall be provided with rating plate having marking as per IS 1180 (part-1):2014 clause no 13 clearly indicating max. total losses at 50% rated load in watts and maximum total losses at 100% rated load in watts
- c) Rating & terminal marking plates shall be combined into one plate and shall be mark with standard mark Govern by the provisions of the BIS act 1986.

TECHNICAL SPECIFICATION OF SINGLE PHASE, 25 KVA, $11/\sqrt{3}/0.25\text{kV}$ OUTDOOR TYPE DISTRIBUTION TRANSFORMER (EEL-1) WITHOUT CSP FEATURE.

- d) Terminals shall be provided with terminal marking plates. The transformer shall be provided with riveted rating plate of minimum 18 SWG aluminum anodized material sheet in a visible position. The entries of the rating plate shall be in indelibly marked (i.e. by etching, engraving or stamping).
- e) Marking as 'M.S.E.D.C.L'S and 'Sr. No.' of transformer shall be engraved on transformer main tank below L.T. bushings.
- f) The name of the company, order No., capacity, month and year of manufacturing shall be engraved on separate plate which shall be firmly welded to main tank and shall form integral part of the tank.
- g) The distribution transformer shall be marked with the Standard Mark. The use of Standard Mark is governed by the provisions of the Bureau of Indian Standards Act, 1986 and the Rules Regulations made thereunder.
- h) In addition to the BIS certification mark license No. (a seven digit number) represented as CM/L xxxxxxx shall be clearly & indelibly marked on the rating plate as per the norms of BIS. The width to height ratio of ISI symbol shall be 4:3.
- i) The copy of valid ISI licence shall be submitted in support with the bidding document.
- j) Each transformer shall be provided with rating plate having marking as per Cl.no.13 of IS 1180(Part 1): 2014 clearly indicating maximum total losses at 50% rated load in watts and maximum total losses at 100% rated load in watts.
- k) Following details shall also be given on the rating plate as per Fig.2 of Cl.no.13.1 of IS 1180(Part 1): 2014 and terminal marking plate with diagram shall be in accordance with Cl.no.13.2 of IS 1180(Part 1): 2014.
- (i) ISI Mark.
- (ii) Energy Efficiency level as approved by BIS
- (iii) Order No. - Month & year.
- (iv) Sr.No. of transformer.
- (v) Date of manufacturing - Month & year.
- (vi) Date of expiry of guarantee period - month & year.
- (vii) Maximum guaranteed 50% load loss & 100 % load loss figures.
- (viii) Name and full address of the manufacturer.
- (ix) Capacity.
- (x) Rating.

(All details on the rating and diagram plate shall be indelibly marked i.e. by engraving or stamping or etching).

TECHNICAL SPECIFICATION OF SINGLE PHASE, 25 KVA, $11/\sqrt{3}$ 0.25kV OUTDOOR TYPE DISTRIBUTION TRANSFORMER (EEL-1) WITHOUT CSP FEATURE.

11.00 Tank base channel :

The tank base channel for 16KVA & 25 kVA transformers – 75 mm x 40 mm.

12.00 Pressure release device:

The transformer shall be equipped with a self-sealing pressure release device design to operate at a minimum pressure of 8-PSI (0.564 kg/cm²).

13.00 Protection: NO CSP features is required.**14 Lightning Arrestors:**

High surge capacity of 9 kV(Vrms), 5 kA(8/20 micro wave shape) Lightning Arrestor for $11/\sqrt{3}$ kV transformers conforming to IS: 3070/1974 shall be mounted on the transformers, clamped securely to the tank, to protect the transformer and associated line equipment from the occasional high voltage surges resulting from lightning or switching operations. The earthing terminal of the lightning arresters shall be connected solidly to the transformer tank earthing terminal.

15 Fittings

The following standard fittings shall be provided.

- Two earthing terminals with earthing symbol.
- Oil level gauge indicating oil level at minimum, 30°C and maximum operating temperature. - 1 No.
- Pressure release device. - 1 No
- Rating and terminal marking plates. - 1 No.
- Thermometer pocket with cap - 1No.
- Oil filling holes having 1 1/4" nominal size thread) with cover. 1 No.
- An extended pipe connection on upper end with welded cover. The pipe should be suitably threaded over a sufficient length to enable use of a refilling / siphon connection after removing the welded cover or any other similar arrangement capable of reuse; - 1 No.
- Two lifting lugs for the complete transformer as well as for core and winding assembly. - 2 No.
- Nitrogen / air filling device / pipe with welded cover capable of reuse. 1 No.
- LV earthing arrangement
 - Metal oxide lightning surge arrester with Dis-connector. 1 No.
 - HV bushings - 1 No.
 - LV bushings.- 2 No.
 - HV & LV terminal connectors
 - Top cover- fixing clamps - 4 No.
 - Mounting lugs – 2
 - Protection cover (Plasticized cover on live parts)
 - Five year guarantee plate - 1 No.
 - HV fuse - 1 No.
 - Drain Valve of 20 MM size - 1 No.
 - Any other fitting necessary for satisfactory performance.

TECHNICAL SPECIFICATION OF SINGLE PHASE, 25 KVA, $11/\sqrt{3}/0.25\text{kV}$ OUTDOOR TYPE DISTRIBUTION TRANSFORMER (EEL-1) WITHOUT CSP FEATURE.
16 Fasteners.

- All bolts, studs, screw threads, pipe threads, bolt heads and nuts shall comply with the appropriate Indian standards for metric threads or the technical equivalent.
- Bolts or studs shall not be less than 6 mm in diameter except when used for small wiring terminals.
- All nuts and pins shall be adequately locked.
- Wherever possible bolts shall be fitted in such a manner that in the event of failure of locking resulting in the nuts working loose and falling off, the bolt will remain in position.
- All ferrous bolts, nuts and washers placed in outdoor positions shall be treated to prevent corrosion by hot dip galvanizing except high tensile steel bolts and spring washers, which shall be Electro, galvanized. Appropriate precautions shall be taken to prevent electrolytic action between dissimilar materials.
- Each bolt or stud shall project at least one thread but not more than three threads through the nut, except when otherwise approved for terminal board studs or relay stems. If bolts are provided at inaccessible places for ordinary spanners, special spanners shall be provided.
- The length of screwed portion of the bolts shall be such that no screw thread may form part of a sheer plane between members.
- Taper washers may be provided where necessary. Protective washers of suitable material shall be provided front and back of the securing screws.
- 4 nos antitheft stainless steel fasteners with breakaway nut shall be provided at the top cover.

17 Transformer Oil:

Transformer oil to be used in all the Distribution transformers shall comply with the requirements of latest IS 335/2018 amended up to date thereof.

The Unused Mineral Insulating Oils (type II) are obtained by distillation and refining of crude petroleum as required to meet the properties specified below.

Sr. No.	Property	Test Method	Permissible Values
A. Function			
1.	Viscosity at 40°C	IS : 1448 (Part 25)	15 mm ² /s, Max.
2.	Viscosity at 0°C	IS : 1448 (Part 25)	1800 mm ² /s, Max.
3.	Pour – Point	IS : 1448 (Part 10/Sec2)	- 10°C, Max. , to be based on LCSET
4.	Water content	IEC 60814	30 mg/kg , Max. / 40 mg/kg, Max.
5.	Breakdown voltage	IS : 6792	30kV / 70kV, Min.
6.	Density at 20°C	IS : 1448 (Part 16)	0.895 g / ml. Max.
7.	DDF at 90°C	IS : 16086	0.005, Max.
8.	Particle content	IS : 13236	No general requirement.
B. Refining / stability			
9.	Appearance	----	Clear, free from sediment and suspended matter.
10.	Acidity	IEC 62021-1	0.01 mg.KOH / g, Max.
11.	Interfacial tension	ASTM D 971	No general requirement.
12.	Total sulphur content	ISO 14596 or ASTM D 4294	No general requirement.
13.	Corrosive sulphur	DIN 51353	Not corrosive.

TECHNICAL SPECIFICATION OF SINGLE PHASE, 25 KVA, 11/√3/0.25kV OUTDOOR TYPE DISTRIBUTION TRANSFORMER (EEL-1) WITHOUT CSP FEATURE.

14.	Potentially corrosive sulphur	IS : 16310	Not corrosive.
15.	DBDS	IS : 16497 (Part 1)	Not detectable (<5mg/kg)
16.	Inhibitors according to IS : 13631 / IEC : 60666	IS : 13631	(U) Uninhibited oil: not detectable (<0.01%)
			(T) Trace inhibited oil : <0.08%
			(I) Inhibited oils : 0.08%-0.40%
17.	Metal passivator additives according to IS : 13631 / IEC : 60666	IS : 13631	Not detectable (<5mg/kg)
18.	Other additives	---	See 7
19.	2-Furfural and related compounds content	IS : 15668	Not detectable (<5mg/kg) For each individual compound.
C. Performance			
20.	Oxidation stability	IS : 15668(Method C) (U) Uninhibited oil : 164h (T) Trace inhibited oil :332h (I) Inhibited oil :500h	For oils with other antioxidant additives and metal passivator.
a)	• Total acidity,9	1.9.4 of IS : 12422	1.2mg KOH/g, Max.
b)	• Sludge,9	1.9.1 of IS : 12422	0.8%, Max.
c)	• DDF at 90°C. 9	1.9.6 of IS : 12422	0.500, Max
21.	Gassing tendency	IEC : 60628, Method A	No general requirement.
22.	ECT	--	No general requirement.
D. Health, Safety and Environment (HSE)			
23.	Flash point	IS : 1448 (Part 21)	135°C, Min.
24.	PCA content	IP : 346	3%, Max.
25.	PCB content	IS : 16082	Not detectable (<2mg/kg)

Refer Note to table no. 2 of IS: 335; 2018

18 Oil leakage test:

The oil leakage test shall be conducted on one unit selected from the offered lot of each rating. Transformer complete in all respects shall be subjected to the pressure of 0.4 kg/cm² and maintained for 10 minutes. No leakage should occur.

19 Test and Inspection:-
19.01 Routine Tests:-

- i) All transformers shall be subjected to the following routine tests at the manufacturer's works. The tests are to be carried out in accordance with the details specified in IS 2026(Part I and III) or as agreed upon between the purchaser and the manufacturer.

1. Measurement of winding resistance.

2. Measurement of Voltage Ratio.

TECHNICAL SPECIFICATION OF SINGLE PHASE, 25 KVA , 11/√3/0.25kV OUTDOOR TYPE DISTRIBUTION TRANSFORMER (EEL-1) WITHOUT CSP FEATURE.

3. Measurement of Short- circuit Impedance.
4. Load losses at 50% & 100 % loading.
5. No-load losses and No-load current.
6. Insulation resistance.
7. Induced over voltage withstand.
8. Separate source voltages withstand.
9. Pressure test as per clause 21.5 of IS 1180 (Part I):2014
10. Oil leakage test as per clause 21.5 of IS 1180 (Part I):2014

All the routine tests shall be conducted in the suppliers' laboratory at their cost.

- ii) Heat run test shall be arranged free of cost on the unit selected from the 1st lot by Executive Engineer/Authorized Representative.
- iii) The calculations to confirm the thermal ability as per Clause no. 9.1 of latest IS: 2026 Part-I or equivalent International Standard shall be submitted to Executive Engineer (IW).

19.02 Challenge Testing :

The manufacturer can also request challenge testing for any test based on specification and losses. The challenger would request for testing with testing fees. The challenge test fees are proposed at least three times the cost of testing. This is likely to deter unnecessary challenges. The challenger would have the opportunity to select the sample from the store and any such challenge should be made within the guarantee period. The party challenged, challenger and the utility could witness the challenge testing.

The challenge testing would cover following tests:

1. Measurement of magnetizing current.
2. No load losses test.
3. Load losses test (at 50 % loading or as per acceptance test).
4. Temperature rise test.

The challenge test could be conducted at NABL Laboratory, like ERDA and CPRI. If the values are within the limits the products gets confirmed else not confirmed. No positive tolerances in losses is permitted. If the product is not confirmed the manufacturer would pay the challenge fee and challenger would get the fee refunded. However as a system of redress the challenger would be allow to ask for fresh testing of two or more samples from the store and the same be tested in NABL Laboratory in presence of party challenge, challenger and the utility.

If any one of the above sample does not confirm the test, then the product is said to have failed the test. In such cases the manufacturer will be declared as unsuccessful manufacturer for the said product with wide publicity and would not allow to complete in tenders of the MSEDCL for the period of three years and heavy penalty would be imposed.

19.03 Type Tests:-

In addition to routine test as above the Tests as under shall be successfully carried out at laboratories accredited by National Accreditation Board for Testing and Calibration Laboratories (NABL) in accordance with IS 1180(Part 1):2014 as amended from time to

TECHNICAL SPECIFICATION OF SINGLE PHASE, 25 KVA , 11/√3/0.25kV OUTDOOR TYPE DISTRIBUTION TRANSFORMER (EEL-1) WITHOUT CSP FEATURE.

time and technical specifications, within the last 5 (five) years prior to the date of offer. The bidder shall furnish the following type tests reports (along with General arrangement drawing, Rating and Diagram Plate and Internal Constructional drawing) along with the offer.

- i) Impulse Voltage with stand Test shall be carried out as per Clause No. 14 of IS 2026 (Part-III) on HV phase chopped on tail.
- ii) Dynamic Short circuit Test (IS 2026 (Part 5) (Routine tests before and after short circuit test shall be conducted as per IS 1180 (Part I): 2014.
- iii) Temperature – rise Test [IS 2026(Part 2)]
- iv) Pressure Test [IS 1180 (Part 1):2014 clause 21.5]
In addition to that the successful bidder shall submit the type test report of Circuit breaker/MCCB (Sequence-1,2,3), HT Fuse, Transformer oil & HV/LV Bushings as per relevant Indian Standards shall submit along with offer.

19.04 In case of any of the following, the offer will not be considered for evaluation.

19.04.1 If above tests are carried out beyond 5 years

19.04.2 Impulse Voltage Withstand test and Dynamic Short Circuit test, Temperature rise test, Pressure test carried out not from NABL approved Laboratory.

19.05 The type test reports should be submitted and got approved from the Chief Engineer (T&QC).

19.06 In respect of the successful bidder, the purchaser reserves the right to demand repetition of some or all the type tests in presence of the purchaser's representative. In case the unit fails in the type tests, the complete supply shall be rejected. The bidders are therefore requested to quote unit rates for carrying out each type test, which however, will not be considered for evaluation of the offer.

20 Drawings :-

Following drawings shall be uploaded by the bidder duly sealed & signed if bidder does not agree to supply the transformers as per MSEDCL standard drawings as given in standard GTP attached with this specification Rating & Diagram Plate Drawing.(As per Cl.no.13.1 Fig.1 of IS 1180(Part1):2014

- i. Rating & Diagram Plate Drawing.
- ii. General Dimensional drawing.
- iii. Core Assembly drawing.
- iv. Internal Construction Drawing
- v. HV Bushings Assembly and Creepage distances.
- vi. LV Bushings Assembly and Creepage distances.
- vii. BEE Star Label Drawing

20.01 The drawings shall be of A-3 (420 x 297 mm) size only. The bidder should also supply along with his offer the pamphlets/literatures etc. for fittings / accessories.

20.02 The successful Bidders shall submit complete set of Drawings (as listed in Cl.No.20.1) of transformer in triplicate indicating dimensions to CE (T&QC) for approval and get approved it before offering 1st stage inspection.

TECHNICAL SPECIFICATION OF SINGLE PHASE, 25 KVA , $11/\sqrt{3}/0.25\text{kV}$ OUTDOOR TYPE DISTRIBUTION TRANSFORMER (EEL-1) WITHOUT CSP FEATURE.

20.03 The successful bidder shall invariably submit the Heat Dissipation Calculation along with offer.

20.04 The bidder should not change design once offered as per A/T, approved drawings and Type Test Reports.

21 Rejection :-

Apart from rejection due to failure of the transformer to meet the specified test requirements the transformer shall be liable for rejection due to any one of the following reasons.

21.01 Total losses at 50 % & 100 % loading exceeds the values mentioned above in the specification.

21.02 Impedance voltage value exceeds the Guaranteed value plus tolerances as mentioned above in the specification.

21.03 Type test are not carried out as mentioned in above specification.

21.04 Drawings are not submitted as given in the specification.

21.05 GTP not submitted as per schedule "A" given in the specification.

21.06 Heat dissipation calculation sheet are not submitted as per the specification.

22 Guaranteed Technical Particulars:

The bidder should fill up all the details in GTP parameter list, the statement such as "as per drawings enclosed", "as per MSEDCL's requirement" "as per IS" etc. shall be considered as details are not furnished and such offers shall be liable for rejection.

23 Testing facility

The bidder should have adequate testing facility for all routine and acceptance tests as specified above and also arrangement for measurement of losses, resistance, etc. details of which will be enumerated in the tender.

24 Submission Routine Test Certificate

The successful bidder shall submit the routine test certificate along with documentary evidence for having paid the Excise Duty for the following raw materials viz. Oil, copper/aluminum for conductors, insulating materials, core materials, bushings at the time of routine testing of the fully assembled transformer.

25 Instruction and operation Manual

The successful bidder shall be required to submit 5 copies of instruction and Operation manual for each lot of 100 Transformers (or part thereof) supplied. This instruction manual should give complete details about the pre-commissioning tests/checks and the details of preventive maintenance etc.

26 Stage Inspection :-

1. After receipt of LoA, Supplier shall give 15 days' advance intimation to the Chief Engineer(MMD) to organize stage inspection.

TECHNICAL SPECIFICATION OF SINGLE PHASE, 25 KVA, $11/\sqrt{3}$ /0.25kV OUTDOOR TYPE DISTRIBUTION TRANSFORMER (EEL-1) WITHOUT CSP FEATURE.

2. After receipt of intimation from successful bidder, Chief Engineer (MMD) will depute MSEDCL's representative to visit factory of bidder for Stage Inspection.
3. Activities below will be carried out during Stage Inspection:
 - (a) Verification of available raw material stock & its quality.
 - (b) Verification of assembly of core, windings and other core materials.
 - (c) Verification of Raw materials such as core stamping, winding conductor, oil etc. Bidder shall use these materials manufactured/supplied by the standard manufacturers and furnish the manufacturer's test certificates, proof of purchase from those manufacturers, documentary evidence for having paid the excise duty for the information of the department.
 - (d) Verification of Performance certificate issued by MSEDCL for earlier transformers supplied by bidder and document of compliance done by manufacturer against failure of supplied transformers in previous tenders of MSEDCL, if any.
 - (e) Verification of original type tests reports, Drawings & GTP, if required.
4. After satisfactory inspection, MSEDCL's representative will give clearance to the bidder/manufacturer for further process.
5. MSEDCL's representative may visit factory at any stage of manufacturing process to verify effective use of inspected raw material. The successful bidder shall grant free access to the MSEDCL's representatives at a reasonable time when the work is in progress.

27 Final Inspection

1. After completion of manufacturing process of all quantity (Lot) as per MSEDCL's clearance letter, Supplier shall give intimation to the Chief Engineer (MMD) to organize final inspection.
2. After receipt of intimation from successful bidder, Chief Engineer (MMD) will depute MSEDCL's representative to visit factory of bidder for final Inspection.

Activities below will be carried out during final Inspection:

- (a) Visual inspection of outer side, design, dimensions, color, name plate etc. of all (100%) ready transformers from offered lot.
- (b) After visual inspection, Inspector will select 10% quantity of transformers at random from offered and visually inspected lot.
- (c) 10 % of the transformers offered will be tested without opening the transformer for all Routine tests as per MSEDCL's technical specifications & related IS. Heat Run Test will have to be carried out on one transformer having maximum total Losses at 100% load.
- (d) Out of balance 90% distribution transformers, one transformer shall be opened and all design technical parameters should be checked as per approved GTP, approved drawings and technical specifications.
- (e) If any technical parameters are found deviating from the approved GTP, approved drawings & technical specifications during final inspection, whole lot shall be reoffered for final inspection after rectification.

TECHNICAL SPECIFICATION OF SINGLE PHASE, 25 KVA , $11/\sqrt{3}/0.25\text{kV}$ OUTDOOR TYPE DISTRIBUTION TRANSFORMER (EEL-1) WITHOUT CSP FEATURE.

3. After satisfactory final inspection, MSEDCL's representative will give clearance to the bidder/manufacturer for dispatch to allotted store

28 Testing of all Distribution Transformers for total losses at 50% load and 100% load at MSEDCL Stores:

After receipt of transformers at stores centers, all distribution transformers from the lot will be tested for total Losses at 50% load and 100% load at all stores by MSEDCL as well as by a third party NABL lab like ERDA, etc. Supplier has liberty to be present at the time of testing.

29 Random Sample Testing (RST)

- 29.01 The bidder should intimate to Chief Engineer (MMD) of completion of dispatches of whole lot of Distribution Transformers to stores against this tender.
- 29.02 Chief Engineer (MMD), M.S.E.D.C.L will select the stores for Random Sample Testing (RST) and depute Executive Engineer (Testing) to carry out RST of the lot.
- 29.03 Advance intimation of 15 days will be given to supplier for joint inspection.
- 29.04 The date of RST will not be altered to the convenience or request of supplier. If supplier's representative fails to attend on the date fixed for RST, the RST will be carried out in his absence and results of RST will be binding on supplier. In case the selected transformer fails in any of the tests, complete lot of transformers will be rejected.
- 29.05 Activities below will be carried out by EE (Testing) during Random Sample Testing: Visual inspection of design, dimensions, color, name plate, radiator, bushings, LAs, Conservator tank, breather etc. of all (100%) transformers from supplied lot.
- 29.06 EE (Testing) will select one transformer at random from the lot of transformers already tested for total Losses at 50% load and 100% load which shall be opened and all design technical parameters shall check as per approved GTP, approved drawings and technical specifications.
- That Selected transformer for random testing shall be tested for all routine testing before opening.
- 29.07 If any technical parameters are found deviating from the approved GTP, approved drawings & technical specifications during Random Sample Testing, whole lot shall be rejected

30 Inspection & Testing of Transformer Oil:

To ascertain the quality of the transformer oil, the original manufacturer's test report should be submitted at the time of inspection. Also arrangements should be made for testing of transformer oil, after taking out the sample from the manufactured transformers and tested in the presence of purchaser's representative or in an independent laboratory.

TECHNICAL SPECIFICATION OF SINGLE PHASE, 25 KVA , $11/\sqrt{3}$ /0.25kV OUTDOOR TYPE DISTRIBUTION TRANSFORMER (EEL-1) WITHOUT CSP FEATURE.

31 Loading of transformer:

The transformer shall be suitable for loading as per IS2026,Part-7. The tenderer should state clearly the percentage overload the transformer can take for a continuous period of one hour.

32 Quality Assurance

The bidder shall invariably furnish following information along with the offer failing to which the offer will be rejected.

Certificates of following materials.

- Aluminium / Copper conductor
- Transformer oil
- Core
- Insulating paper.
- Porcelain Bushings
- Steel Plate used for Tank

- 32.01 Names of the supplier for the raw material, list of standard accordingly to which the raw materials are tested, list of test normally carried out on raw materials in presence of bidder's representatives, copies of type test certificates.
- 32.02 Information and copies of test certificate as in (i) above respect of bought out accessories including terminal connectors.
- 32.03 List of manufacturing facilities available. In this list the bidder shall specifically mention whether lapping machine, vacuum drying plant, air conditioned dust free room with positive air pressure for provision of insulation and winding etc are available with him.
- 32.04 Level of automation achieved and list of areas where manual processing still exists.
- 32.05 List of areas in manufacturing process where stage inspection are normally carried out for quality control and details of such tests and inspections.
- 32.06 Special features provided in the equipments to make it maintenance free
- 32.07 List of testing equipment available with the bidder for final testing of transformers and test plant limitation, if any, vis-à-vis the type, special acceptance and routine tests specified in the relevant standards and the present specification.
- 32.08 The successful bidder shall submit the Routine Test Certificate along with documentary evidence having paid for the excise duty for the following raw materials viz Oil, Copper for conductors, insulating materials, Core materials, Bushing at the time of routine Testing of the fully assembled transformer.

33 Qualifying Requirement: As per Tender.

TECHNICAL SPECIFICATION OF SINGLE PHASE, 25 KVA , $11/\sqrt{3}$ /0.25kV OUTDOOR TYPE DISTRIBUTION TRANSFORMER (EEL-1) WITHOUT CSP FEATURE.

34 Performance Guarantee:

All transformers supplied against this specification shall be guaranteed for a period of 66 months from the date of receipt at the consignee's Stores Center or 60 months from the date of commissioning, whichever is earlier. However, any engineering error, omission, wrong provisions, etc. which do not have any effect on the time period, shall be attended to as and when observed/ pointed out without any price implication.

TECHNICAL SPECIFICATION OF SINGLE PHASE, 25 KVA , $11/\sqrt{3}$ /0.25kV OUTDOOR TYPE DISTRIBUTION TRANSFORMER (EEL-1) WITHOUT CSP FEATURE.

Annexure I

Air Pressure Test

Name of Supplier:

Order No.:

Capacity & Voltage Ratio of Distribution Transformer : _25___ kVA, ___/0.250 kV

Sr. No. of equipment Tested:

Date of Testing:

Reference Standard

All the opening of the transformer tank were closed with suitable gasket, bushing, valves and plugs. The compressor pipe connected at oil filling hole on tank surface and a pressure gauge was fitted at air vent plug. The parallel string were placed around the tank, the distance between string and tank as shown in following diagram (indicative drawing) were recorded before applying the pressure and after releasing pressure.

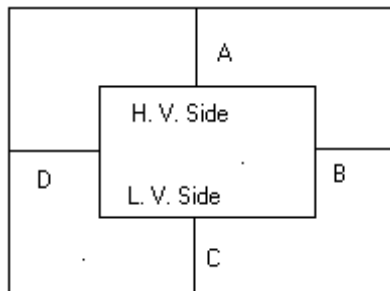

Tank Thickness: Side _____ mm. Top & Bottom _____ mm

Test Pressure: _____ kg/cm² applied for 30 Minutes.

Test Point	Distance before Test In mm	Distance after release of Pressure in mm	Deflection In mm
A			
B			
C			
D			

Permanent Deflection : _____ mm. Permissible Limit of Permanent Deflection as per Specification : _____ mm

Test witnessed by

Tested by

Annexure II

Temperature Rise Test

Name of Supplier:

Tech spec No.CE/T&QC/MSD/DTC Rev Date: 01.03.2023

TECHNICAL SPECIFICATION OF SINGLE PHASE, 25 KVA, 11/√3/0.25kV OUTDOOR TYPE DISTRIBUTION TRANSFORMER (EEL-1) WITHOUT CSP FEATURE.

Order No.:

Capacity & Voltage Ratio of Distribution Transformer : 25 kVA, / 0.250 kV

Sr. No. of equipment Tested:

Date of Testing:

Reference Standard

	H. V. Winding	L. V. Winding
Rated Line Current in Amp		
Guaranteed No Load Losses	_____ watt	
Load Losses	_____ watt	
Total Losses	_____ watt	

P. T. Ratio : / =C. T. Ratio : / =

Wattmeter Constant =

Total Multiplying Factor (MF) =

TIME	Ambient Temp.				Top Oil Temp. °C	Rise in Top Oil Temp. °C	Line Voltage in Volts	Line Current in Amps	W1 watts	Multiplying Factor (MF)	Total Watt
	T1 °C	T2 °C	T3 °C	Average °C							
Reduced to Rated Current _____ amps											

Calculation of Temperature Rise in Winding

LV Winding : Since the resistance of LV winding is less than 0.005 ohm, Temperature Rise in LV Winding is taken as temperature rise of oil as per clause no. 4.3 of IS:2026 (Part II)/1977

Temperature Rise in LV Winding = _____ °C

HV Winding Resistance at _____ °C = _____ ohm

TECHNICAL SPECIFICATION OF SINGLE PHASE, 25 KVA , 11/√3/0.25kV OUTDOOR TYPE DISTRIBUTION TRANSFORMER (EEL-1) WITHOUT CSP FEATURE.

Measurement of Hot Resistance of HV Winding after Shut Down.

Time	Resistance

Hot winding Resistance at Ambient Temperature _____ °C (from graph) = _____ Ohm

Temperature Rise in H. V. Winding is

$$= \frac{\text{Hot Resistance} \times (235 + \text{Cold Ambient Temperature})}{\text{Cold Resistance}} - (235 + \text{Hot Ambient Temperature})$$

Results :

- 1) Temperature Rise in Oil = _____ °C
- 2) Temperature Rise in LV Winding = _____ °C
- 3) Temperature Rise in HV Winding = _____ °C

Test witnessed by

Tested by

ANNEXURE - "A"

GUARANTEED TECHNICAL PARTICULARS		
SR. NO.	PARTICULARS	NOMENCLATURE
1.0	Name of Manufacturer	TEXT
2.0	Reference Standard	TEXT

TECHNICAL SPECIFICATION OF SINGLE PHASE, 25 KVA , $11/\sqrt{3}/0.25\text{kV}$ OUTDOOR TYPE DISTRIBUTION TRANSFORMER (EEL-1) WITHOUT CSP FEATURE.

3.0	Energy efficiency <u>level</u> as per IS 1180 Part-I(2014)	TEXT
4.0	Whether transformer is Oil Natural Air Natural cooled type (Yes/No)	BOOLEAN
5.0	Whether transformer is suitable for Indoor /Outdoor installation	TEXT
6.0	Rating of Transformers in KVA	NUMERIC
7.0	Primary Voltage in KV	NUMERIC
8.0	Secondary Voltage in KV	NUMERIC
9.0	Whether neutral is solidly earthed (Yes/No)	BOOLEAN
10.0	Colour of transformer	TEXT
11.0	Approximate overall breadth of transformer in mm	NUMERIC
12.0	Approximate overall height of transformer in mm	NUMERIC
13.0	Approximate Diameter of transformer tank in mm	NUMERIC
14.0	Approximate height of transformer tank in mm	NUMERIC
15.0	Thickness of the side of transformer Tank plate in mm	NUMERIC
16.0	Thickness of the bottom of transformer tank plate in mm	NUMERIC
17.0	Thickness of the top of transformer tank plate in mm.	NUMERIC
18.0	Total Radiating surface of transformer tank in sq. mtrs	NUMERIC
19.0	Size of base channel provided to tank and no.s	NUMERIC
20.0	Weight of Tank & fittings in kgs	NUMERIC
21.0	Weight of Core in kgs	NUMERIC
22.0	Weight of winding in kgs	NUMERIC
23.0	Weight of Oil in kgs	NUMERIC
24.0	Volume of Oil in Ltrs	NUMERIC
25.0	Total Weight of Transformer in kgs	NUMERIC

TECHNICAL SPECIFICATION OF SINGLE PHASE, 25 KVA , 11/√3/0.25kV OUTDOOR TYPE DISTRIBUTION TRANSFORMER (EEL-1) WITHOUT CSP FEATURE.

26.0	Core material used & its grade	TEXT
27.0	Type of core	TEXT
28.0	No. of steps of core for CRGO core	NUMERIC
29.0	Diameter of core in mm	NUMERIC
30.0	Effective core area.(sq.cm)	NUMERIC
31.0	Core Window Height in mm	NUMERIC
32.0	Centre to Centre Distance in mm	NUMERIC
33.0	Flux density in Tesla	NUMERIC
34.0	Thickness of core lamination in mm	NUMERIC
35.0	The temperature shall in no case reach a value that will damage the core itself, other parts or adjacent materials ,Max. temperature.	NUMERIC
36.0	Material of H.V winding	TEXT
37.0	Material of L. V. Winding	TEXT
38.0	Insulation provided to H.V winding.	TEXT
39.0	Insulation provided to L.V. winding.	TEXT
40.0	Current density of H.V. winding (in Ampere/ sq.mm)	NUMERIC
41.0	Current density of L.V. winding (in Ampere/ sq.mm)	NUMERIC
42.0	No. of LV Winding Turns	NUMERIC
43.0	No. of HV Winding Turns	NUMERIC
44.0	Resistance of LV winding per phase at 20 oC in Ohms	NUMERIC
45.0	Resistance of HV winding per phase at 20 oC in Ohms	NUMERIC
46.0	Clearance between Core & L.V. winding in mm	NUMERIC
47.0	Clearances between L.V. & H.V. winding in mm	NUMERIC

TECHNICAL SPECIFICATION OF SINGLE PHASE, 25 KVA , $11/\sqrt{3}/0.25\text{kV}$ OUTDOOR TYPE DISTRIBUTION TRANSFORMER (EEL-1) WITHOUT CSP FEATURE.

48.0	Clearances between end insulation to Earth in mm	NUMERIC
49.0	Clearances between winding to tank in mm (min 30 mm).	NUMERIC
50.0	Insulation materials provided for core	NUMERIC
51.0	Length of coil used for HV winding in meter.	NUMERIC
52.0	Diameter of conductor used for HV winding (in mm)	NUMERIC
53.0	Cross section area of the coil used for HV winding (sq.mm)	NUMERIC
54.0	Length of coil used for LV winding in meter.	NUMERIC
55.0	Size of strip used for LV winding in mm	NUMERIC
56.0	No. of conductors in parallel for LV winding	NUMERIC
57.0	Total cross section area of LV conductor in sq. mm	NUMERIC
58.0	No. of H.V coils	NUMERIC
59.0	Thickness of locking spacers between H.V. coils (in mm)	NUMERIC
60.0	Quantity of total oil absorption (in liters) in first filling	NUMERIC
61.0	Total oil volume including Total Oil absorption in Ltrs.	NUMERIC
62.0	Grade of Oil used.	TEXT
63.0	Name of Oil manufactures to be supplied.	TEXT
64.0	Breakdown Values of Oil at the time of first filling (kV/mm) considering 2.5 mm gap	NUMERIC
65.0	Drain Valve (20 mm) provided to the transformer tank	TEXT
66.0	Earthing terminals with lugs is provided	TEXT
67.0	Lifting lugs provided	TEXT
68.0	Thermometer pocket is provided	TEXT
69.0	Rating of H.V. Bushings (in kV, A)	NUMERIC
70.0	Rating of L.V. Bushing (in kV, A)	NUMERIC

TECHNICAL SPECIFICATION OF SINGLE PHASE, 25 KVA , $11/\sqrt{3}/0.25$ kv OUTDOOR TYPE DISTRIBUTION TRANSFORMER (EEL-1) WITHOUT CSP FEATURE.

71.0	Material of HV Bushings and makes thereof	TEXT
72.0	Material of LV Bushings and makes thereof	TEXT
73.0	Reference standard of Bushings	TEXT
74.0	Minimum Creepage Distance of HV Bushing in mm (min.25 mm per kV)	NUMERIC
75.0	Minimum Creepage Distance of LV Bushing in mm (min.25 mm per kV)	NUMERIC
76.0	Minimum external clearances of bushing terminals: HV Phase to Earth	NUMERIC
77.0	Minimum external clearances of bushing terminals: LV Phase to Earth	NUMERIC
78.0	Maximum temperature rise of Oil in °C over an Ambient temp. Of 50°C by thermometer.	NUMERIC
79.0	Maximum temperature rise of winding in °C over an Ambient temp. Of 50°C by thermometer.	NUMERIC
80.0	Magnetizing current (No load) in Amps and its 3% of full load current at rated voltage referred to LV Voltage	NUMERIC
81.0	Magnetizing current (No load) in Amps and its 6 % of full load current at maximum voltage (112.5% of rated voltage)referred to LV side	NUMERIC
82.0	Max. Core Loss at rated voltage and rated frequency (Watts)	NUMERIC
83.0	Max. Total Losses (No load+Load losses at 75 °C) at50% Loading (Watts)	NUMERIC
84.0	Max. Total Losses (No load+Load losses at 75 °C) at100% Loading (Watts)	NUMERIC
85.0	Efficiency at 75 °C at unity P.F. at 100% load	BOOLEAN
86.0	Efficiency at 75 °C at unity P.F. at 75 % load	BOOLEAN
87.0	Efficiency at 75 °C at 0.8 P.F. lag at 125% load	BOOLEAN
88.0	Efficiency at 75 °C at 0.8 P.F. lag at 100 % load	BOOLEAN
89.0	Efficiency at 75 °C at 0.8 P.F. leading at 125% load	NUMERIC
90.0	Efficiency at 75 °C at 0.8 P.F. leading at 100% load	NUMERIC
91.0	% Impedance value at 75°C	NUMERIC

TECHNICAL SPECIFICATION OF SINGLE PHASE, 25 KVA , $11/\sqrt{3}/0.25\text{kV}$ OUTDOOR TYPE DISTRIBUTION TRANSFORMER (EEL-1) WITHOUT CSP FEATURE.

92.0	Make HV fuse	TEXT
93.0	Separate source power frequency withstand test for HV for 1 minute in kv(min)	NUMERIC
94.0	Separate source power frequency withstand test for LV for 1 minute in kv(min)	NUMERIC
95.0	Induced over voltage withstand test for 1 min. specify voltage frequency, time for test.	TEXT
96.0	Impulse test value (in kVP) .	TEXT
97.0	All type test report type test carried out on transformer at NABL laboratory shall be submitted along with the offer as per cl. XXII (c) of section (I) i.e. instructions to tenders .	TEXT
98.0	Unbalanced current test, air pressure test and temperature rise test shall be conducted as per format enclosed with the technical specification along the offer .	TEXT
99.0	All drawings shall be furnished with each offered item separately along with the offer.	TEXT
100.0	Oil absorption Calculation sheet shall be furnished with for each offered item separately along with the offer.	TEXT
101.0	Heat Dissipation Calculation sheet shall be furnished with for each offered item separately along with the offer.	TEXT
102.0	Flux Density calculation sheet with no. of Primary & Secondary turns shall be furnished with for each offered item separately along with the offer.	TEXT
103.0	Calculation sheet for 112.5% of rated v/f ratio (Over fluxing calculation sheet) offered shall be furnished with for each item separately along with the offer.	TEXT
104.0	Required documents , plant and machinery , list of order executed /under execution shall be furnished for each offered items separately along with this offer.	TEXT
105.0	The Information required under Quality Assurance shall be submitted with the offer in physical format & soft copy.	TEXT
106.0	The cost data in the prescribed format shall be submitted with the offer in physical format & soft copy .	TEXT
107.0	Firm shall confirm that the distribution transformer complies to the specified requirement of Indian Standard and submit copy of valid ISI licence along with the offer.	TEXT
108.0	The performance guarantee of transformer in Year	NUMERIC

TECHNICAL SPECIFICATION OF SINGLE PHASE, 25 KVA, 11/√3/0.25kV OUTDOOR TYPE DISTRIBUTION TRANSFORMER (EEL-1) WITHOUT CSP FEATURE.

Annexure : "B"

This is an Indicative Drawings

NOTE:

- 1) MONTH & YEAR, SR.NO. & IMPEDENCE VALUES (*) WILL BE PUNCHED AT THE TIME OF DISPATCH
- 2) MATERIAL: ALLUMINIUM ANODISED
- 3) THICKNESS:- 18 SWG MIN.
- 4) WEIGHT ARE SUBJECT TO ± 10% TOLERANCE
- 5) ALL DIMENSIONS ARE IN mm UNLESS OTHERWISE STATED

1	PHASE	ALU WOUND DISTRIBUTION TRANSFORMER WITH CSP FEATURE	
	STANDARD	IS:1180 (PART-1)-2014	
	KVA	25	ENERGY EFFICIENCY LEVEL 2
	VOLTS AT NO LOAD	HV 11000	MAX. TOTAL LOSSES AT 50% RATED LOAD W
		LV 250	MAX. TOTAL LOSSES AT 100% RATED LOAD
	BIL (kVp)	HV 75M	TYPE OF COOLING ONAN
		LV	TEMP RISE OVER AMBIENT 50°C OIL °C 35 WDG °C 40
	AMPERES	HV	MASS OF OIL Kgs
		LV	TOTAL WEIGHT Kgs
	FREQUENCY Hz		VOLUME OF OIL Ltrs.
	VECTOR GROUP	1 phase	YEAR OF MFG *
	IMPEDANCE VOLT%	*	SR. NO. *
	CUSTOMER	MAHARASHTRA STATE ELECTRICITY DISTRIBUTION CO. LTD.	
	ORDER NO	*	
	MADE IN INDIA		
	TERMINAL MARKING & CONNECTION DIAGRAM		

CUSTOMER: MAHARASHTRA STATE ELECTRICITY DISTRIBUTION CO. LTD.
 DRN BY: **RATING & DIAGRAM DRAWING**
 CHD. BY: 25 KVA, 6351/250V, Single phase, ALU. WOUND, TRANSFORMER (ENERGY EFFICIENCY LEVEL-2, AS PER IS : 1180 (PART-1): 2014)
 SCALE: NTS
 DIM.TOL: ±5% DRG NO :-25/ 11 10/ EEL2/ 01

TECHNICAL SPECIFICATION OF SINGLE PHASE, 25 KVA, 11/√3/0.25kV OUTDOOR TYPE DISTRIBUTION TRANSFORMER (EEL-1) WITHOUT CSP FEATURE.

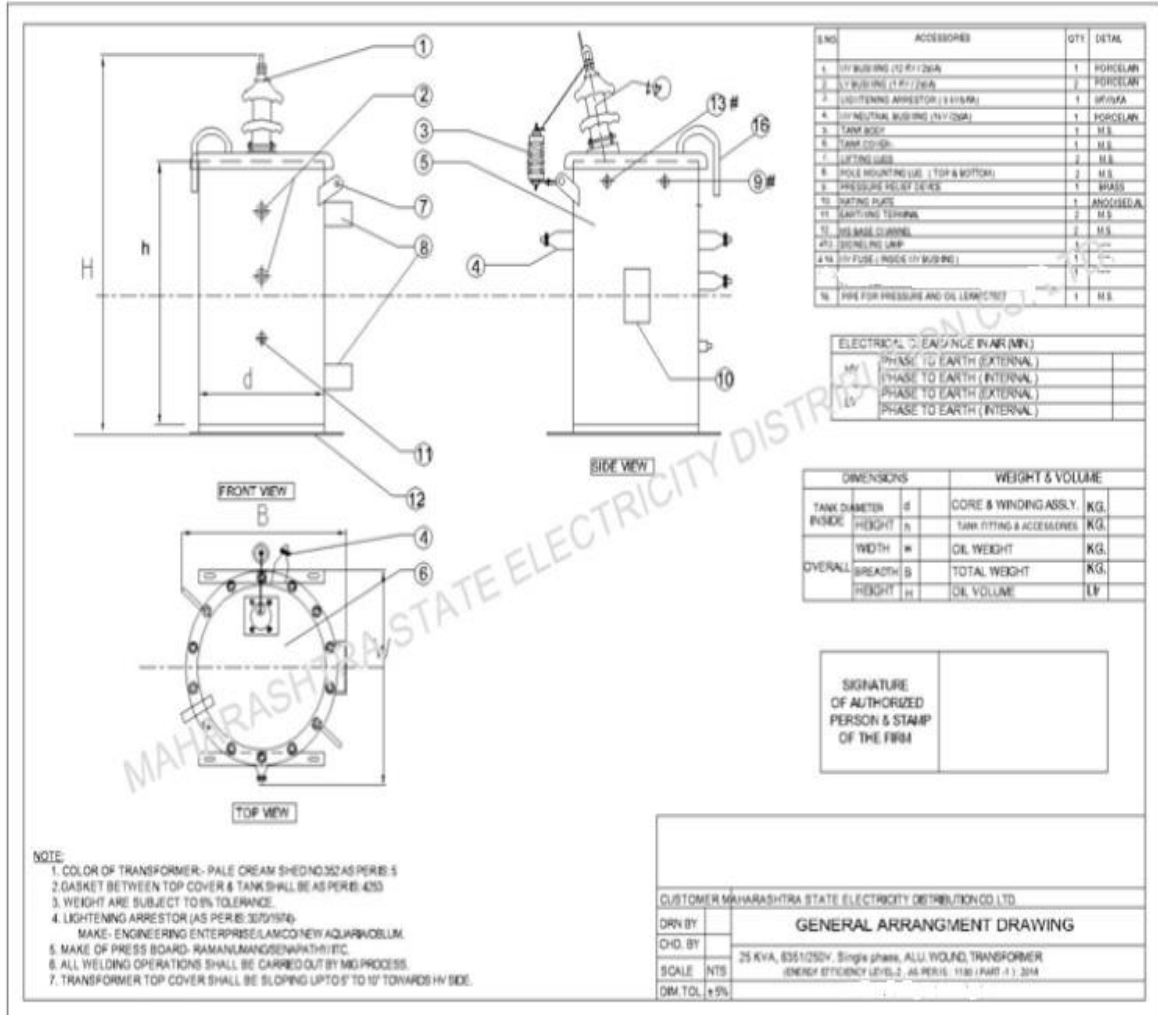

TECHNICAL SPECIFICATION OF SINGLE PHASE, 25 KVA, 11/√3/0.25KV OUTDOOR TYPE DISTRIBUTION TRANSFORMER (EEL-1) WITHOUT CSP FEATURE.

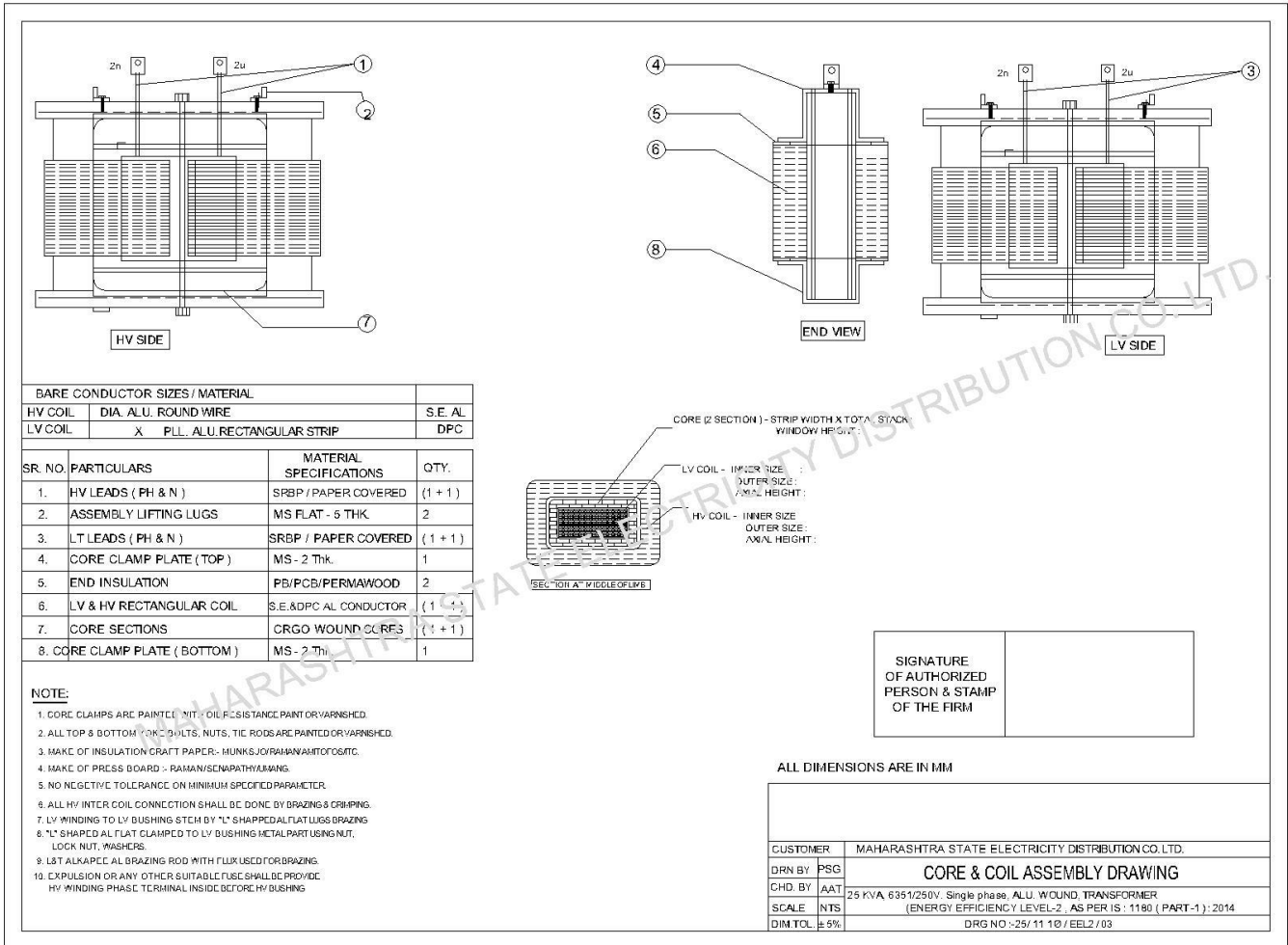

TECHNICAL SPECIFICATION OF SINGLE PHASE, 25 KVA, 11/√3/0.25kV OUTDOOR TYPE DISTRIBUTION TRANSFORMER (EEL-1) WITHOUT CSP FEATURE.

SR. NO.	DESCRIPTION	TECHNICAL DETAILS	As Offered	
			H.V.	L.V.
1.	PRIMARY VOLTAGE (KV)	11000√3		
2.	SECONDARY VOLTAGE (V)	250 V		
3.	RATING (KVA)	25		
4.	POLARITY REF			
5.	CONFORMING TO I.S.S.	IS 2026, 1180(PART-1)2014		
6.	TEMP. RISE OF TOP OIL (MAX) OVER AN AMBIENT TEMP 50°C	35°C		
7.	TEMP. RISE OF WINDING (MAX) OVER AN AMBIENT TEMP 50°C	40°C		
8.	HOT SPOT TEMPERATURE OF WINDING (MAX) OVER AN AMBIENT TEMP 50°C	40°C		
9.	THICKNESS OF CORE LAMINATION			
	a) CORE MATERIAL			
	b) PRINCIPAL SOURCE OF CORE MATERIAL			
	c) GRADE OF LAMINATION			
	e) FLUX DENSITY W/m ²			
	d) CORE INSULATION			
10.	% IMPEDANCE			
11.	CORE DIMENSIONS			

SR. NO.	DESCRIPTION	As Offered	
		H.V.	L.V.
12.	WINDING		
a)	MATERIAL	DPC ALU.	ALU.
b)	CONDUCTOR SIZE mm.		
c)	CONDUCTOR CROSS SECTION mm ²		
d)	INSULATION MATERIAL		
e)	CURRENT DENSITY A/mm ² MAX	1.6 MAX	1.6 MAX
f)	NO. OF TURNS		
g)	OUTER DIAMETER mm.		
h)	INSIDE DIAMETER mm.		
i)	AXIAL LENGTH mm.		
j)	NO. OF COILS PER PHASE NO.		
k)	RESISTANCE PER PHASE Ohms at 20°C		
13.	BUSHING	As Offered	
	MINIMUM CREEPAGE DISTANCE	AS PER IS-3317	AS PER IS-3317
14.	LOSSES:		
	TOTAL LOSSES AT 75°C AT 50% LOAD (Watts) MAX.		
	TOTAL LOSSES AT 75°C AT 100% LOAD (Watts) MAX.		
15.	TANK		
	SIDE WALL THICKNESS mm.		
	TOP & BOTTOM PLATE THICKNESS mm.		
16.	OIL USED		
	NAME OF MANUFACTURER	SANTARAZARHPC OILU PBAH LI	
	GRADE	MINERAL OIL CONFORMING TO IS 335	
	VOLUME OF OIL IN LITRES		

STACK WIDTH (W) mm	
STACK THICKNESS (t) mm	
TOTAL CROSS SECTION AREA	
CRGO CORE STACKING FACTOR	
EFFECTIVE CORE AREA	

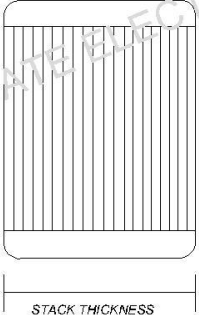

STACK THICKNESS

SIGNATURE OF AUTHORIZED PERSON & STAMP OF THE FIRM

ALL DIMENSIONS ARE IN MM

CUSTOMER	MAHARASHTRA STATE ELECTRICITY DISTRIBUTION CO. LTD.
DRN BY	
CHD. BY	
SCALE	NTS
DIM.TOL.	±5%

TECHNICAL DETAILS

25 KVA, 6351/250V, Single phase, ALU. WOUND, TRANSFORMER
(ENERGY EFFICIENCY LEVEL-2, AS PER IS : 1180 (PART-1) : 2014)

DRG NO. :-25/ 11 10 / EEL2/04

TECHNICAL SPECIFICATION OF SINGLE PHASE, 25 KVA, $11/\sqrt{3}/0.25$ kv OUTDOOR TYPE DISTRIBUTION TRANSFORMER (EEL-1) WITHOUT CSP FEATURE.

TRANSFORMER BUSHING AS PER IS:3347

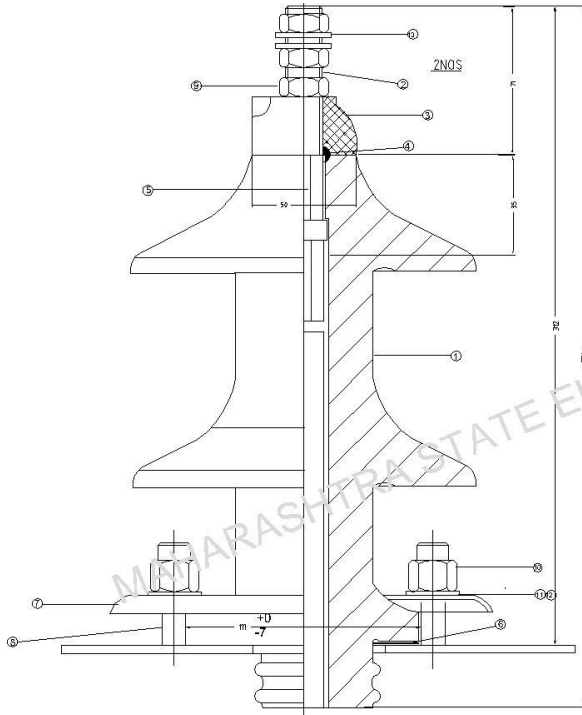

ELECTRICAL CHARACTERISTICS:

1. RATED VOLTAGE : 12 KV
2. RATED CURRENT : 250 Amp
3. POWER FREQUENCY WITHSTAND VOLTAGE : 28 KV
4. IMPULSE WITHSTAND VOLTAGE 75Kvp
5. MIN.CREEPAGE DISTANCE : 25 MM./KV

NOTE:

PERFORMANCE REQUIREMENTS OF THE BUSHING SHALL CONFIRM TO IS: 2099 - 1986
NRBC = NITRILE RUBBER COMPOUND CORK

MAKE:- JAIPUR, SHIPE TALAYAL, GJI, BIKANER, RR.

Sr. No.	DESCRIPTION	MATERIAL	QTY.
1	INSULATOR	PROCLEAN	1
2	STEM- (M12 x 1.75) E. TINNING)	BRASS	1
3	END CAP (E. TINNING)	BRASS	1
4	SEALING WASHER (STEM)	NITRILE RUBBER	1
5	SEPARATOR	ASBESTOS FIBER	1
6	SEALING WASHER FOR GEN. PURPOSE	NRBC	1
7	CLAMPING RING	C R C A STEEL	1
8	CLAMPING MEMBER	AL ALLOY	4
9	HEX.NUT FOR STEM(M12x1.75)(E.TINNING)	BRASS	3
10	HEX.NUT-M-10 (HDG)	M . S.	4
11	PLAIN WASHER-M-10 (HDG)	M . S.	4
12	SPRING WASHER M-10 (HDG)	M . S.	4
13	PLAIN WASHER-M-12 (E. TINNING)	BRASS	2

SIGNATURE
OF AUTHORISED
PERSON & STAMP
OF THE FIRM

ALL DIMENSIONS ARE INMM

CUSTOMER	MAHARASHTRA STATE ELECTRICITY DISTRIBUTION CO. LTD.
DRN BY	HV BUSHING ASSEMBLY DRAWING
CHD. BY	
SCALE	25 KVA, 6351/250V. Single phase ALU. WOUND, TRANSFORMER (ENERGY EFFICIENCY LEVEL-2, AS PER IS : 1180 (PART -1) : 2014
DIM.TOL	± 0.1%
	DRG NO :-25/ 11 10/ EEL2/05

TECHNICAL SPECIFICATION OF SINGLE PHASE, 25 KVA, $11/\sqrt{3}/0.25$ kv OUTDOOR TYPE DISTRIBUTION TRANSFORMER (EEL-1) WITHOUT CSP FEATURE.

CREEPAGE DISTANCE IS MEASURED ALONG THE OUTER PORCLEAIN SURFACE

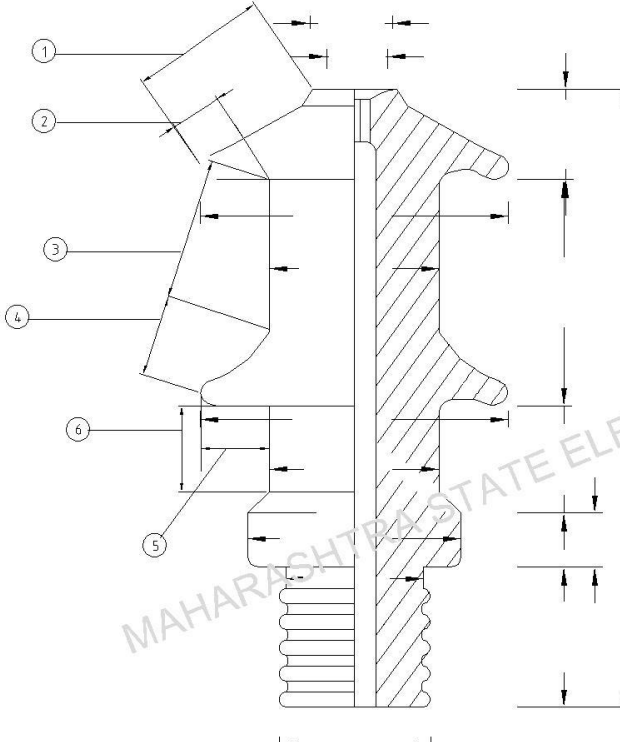

NOTE:

1. DIMENSIONS ARE CONFORMING TO IS : 3347 (PART - III / SEC. 1) - 1988.
2. COLOUR : DARK BROWN .
3. CREEPAGE DISTANCE : mm . (MIN.)

CREEPAGE DISTANCE	
PT.No.	DIM
1	
2	
3	
4	
5	
6	

SIGNATURE
OF AUTHORISED
PERSON & STAMP
OF THE FIRM

ALL DIMENSIONS ARE IN MM

CUSTOMER	MAHARASHTRA STATE ELECTRICITY DISTRIBUTION CO. LTD.
DRN BY	PSG
CHD. BY	AAT
SCALE	NTS
DIM.TOL.	± 5%

CREEPAGE DISTANCE DRAWING OF HLV BUSHING 12KV/250Amps.

25 KVA, 6351/250V. Single phase, ALU. WOUND, TRANSFORMER
(ENERGY EFFICIENCY LEVEL-2, AS PER IS : 1180 (PART-1) : 2014
DRG NO : 25/ 11 10 /EEL2/06

TECHNICAL SPECIFICATION OF SINGLE PHASE, 25 KVA, $11/\sqrt{3}/0.25$ kv OUTDOOR TYPE DISTRIBUTION TRANSFORMER (EEL-1) WITHOUT CSP FEATURE.

TRANSFORMER BUSHING AS PER IS:3347

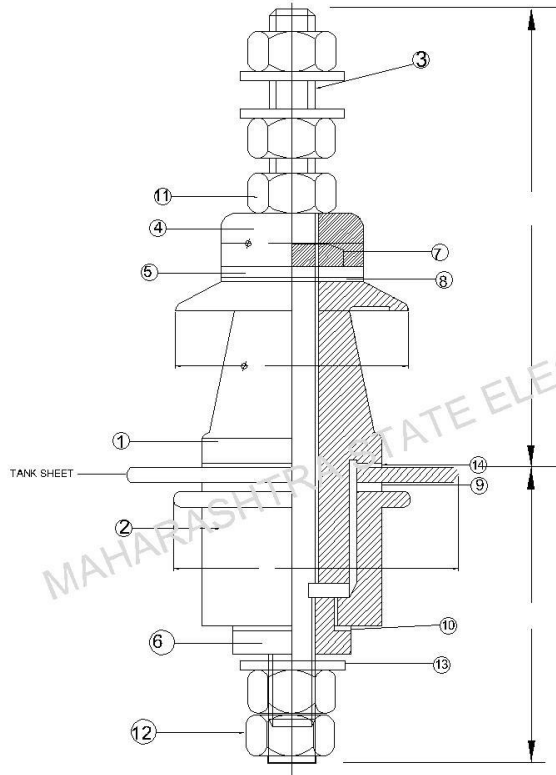

ELECTRICAL CHARECTERISTICS

1. RATED VOLTAGE : 1 KV
2. RATED CURRENT : 250 Amp
3. POWER FREQUENCY WITHSTWVD VOLTAGE : 3 KV
4. MIN.CREEPAGE DISTANCE : MM.

NOTE:

PERFORMANCE REQUIREMENTS OF THE BUSHING SHALL CONFIRM TO IS: 7421 - 1988
NRBC - NITRILE RUBBER LOADED CORK.

MAKE:- JAIPUR, SHINE, TAYAL, C/BIKANER, RR.

SR. No.	DESCRIPTION	MATERIAL	QTY
1	INSULATOR UPPER	PORCELIAN	1
2	INSULATOR LOWER	PORCELIAN	1
3	STEM- (M12 x 1.75) (E. TINNING)	COPPER	1
4	TOP END WASHER (E. TINNING)	BRASS	1
5	STEM WASHER (E. TINNING)	BRASS	1
6	BOTTOM NUT (E. TINNING)	BRASS	1
7	SEALING WASHER (STEM)	SYNTHETIC RUBBER	1
8	SEALING WASHER (TYPE-M)	NRBC	1
9	SEALING WASHER (TYPE-N)	NRBC	1
10	SEALING GASKET	NRBC	1
11	HEX.NUT-(M -12 x 1.75) (E.TINNING)	BRASS	3
12	HEX.LOCK NUT-(M-12x1.75 (E.TINNING)	BRASS	2
13	PLAIN WASHER (TYPE - N)	BRASS	3
14	SEALING WASHER (E. TINNING)	NRBC	1

SIGNATURE OF AUTHORISED PERSON & STAMP OF THE FIRM

ALL DIMENSIONS ARE IN MM

CUSTOMER	MAHARASHTRA STATE ELECTRICITY DISTRIBUTION CO. LTD.
DRN BY	PSG
CHD. BY	AAT
SCALE	NTS
DIM.TOL	± 5%

LV BUSHING ASSEMBLY DRAWING

25 KVA, 6351/250V. Single phase ALU WOUND TRANSFORMER (ENERGY EFFICIENCY LEVEL-2, AS PER IS: 1180) (PART -1), 2014

DRG NO :-25/11 10/ EEL2 / 07

TECHNICAL SPECIFICATION OF SINGLE PHASE, 25 KVA , 11/√3/0.25kv OUTDOOR TYPE DISTRIBUTION TRANSFORMER (EEL-1) WITHOUT CSP FEATURE.

UPPER INSULATOR

LOWER INSULATOR

SIGNATURE OF AUTHORISED PERSON & STAMP OF THE FIRM

CREEPAGE DISTANCE	
PT.No.	DIM
1	
2	
3	
TOTAL	

NOTE:

1. COLOUR - BROWN GLAZED.
2. Min CREEPAGE DISTANCE-25mm/KV
3. AS PER IS: 3347(PART-I/SEC1)
4. ALL DIMENSIONS ARE IN MM

ALL DIMENSIONS ARE IN MM

CUSTOMER	MAHARASHTRA STATE ELECTRICITY DISTRIBUTION CO. LTD.
DRN BY	CREEPAGE DISTANCE DRAWING OF LV BUSHING 1.0KV/250Amps.
CHD BY	
SCALE	25 KVA, 6351.250V, Single phase, ALU. WOUND, TRANSFORMER (ENERGY EFFICIENCY LEVEL-2, AS PER IS: 1190(PART-1): 2011)
DIM.TOL	± 5%
DRG NO :-25/ 11 10 / EEL2 / 08	

TECHNICAL SPECIFICATION OF SINGLE PHASE, 25 KVA , $11/\sqrt{3}$ /0.25kV OUTDOOR TYPE DISTRIBUTION TRANSFORMER (EEL-1) WITHOUT CSP FEATURE.

Annexure C
Technical Specification for QR code generation

1. SCOPE:

The QR Code Generation for Distribution Transformer Identification should be easy to create, compact in size and friendly user. Being compact in size the QR Code requires less space.

2. SERVICE CONDITIONS:

The QR Code laminated P-Touch labels shall be suitable for satisfactory operation under the following tropical conditions.

2.1	Maximum ambient temperature (Degree C)	50
2.2	Maximum temperature in shade (Degree C)	45
2.3	Minimum Temperature (Degree C)	3.5
2.4	Relative Humidity (percent)	10 to 95
2.5	Maximum Annual rain fall (mm)	1450
2.6	Maximum wind pressure (kg/sq.m)	150
2.7	Maximum altitude above mean sea level (Meter)	1000
2.8	Isoceranic level (days per year)	50
2.9	Siesmic level (Horizontal Acceleration)	0.3 g

Moderately hot and humid tropical climate conducive to rust and fungus growth

3. GENERAL TECHNICAL REQUIREMENT:

The QR Code shall be laminated P-Touch labels. The QR Code shall be 2D square barcode which can be store data in encoded format. This saves space and giving specified information to users. This QR Code, if scanned with mobile shall be convert encoded data readable text without error.

4. TECHNICAL DETAILS :

The QR Code laminated P-Touch labels shall be temperature resistant, fade resistant, water resistant, chemical resistant, scratch (abrasion) proof and strong adhesion.

5. TECHNICAL DATA :

The QR Code laminated P-Touch labels with following data shall be provided on transformer.

- 1) Name of Manufacture :
- 2) Rating :
- 3) Sr. No. :
- 4) Date of Manufacturing :
- 5) A/T No. :

6. LOCATION OF QR CODE :

The QR Code laminated P-Touch labels shall be located below the Name Plate on transformer

TECHNICAL SPECIFICATION OF SINGLE PHASE, 25 KVA , $11/\sqrt{3}$ /0.25kV OUTDOOR TYPE DISTRIBUTION TRANSFORMER (EEL-1) WITHOUT CSP FEATURE.

body. It should be clearly visible.

The QR Code laminated P-Touch labels location as below :

TECHNICAL SPECIFICATION OF SINGLE PHASE, 25 KVA , $11/\sqrt{3}/0.25$ kv OUTDOOR TYPE DISTRIBUTION TRANSFORMER (EEL-1) WITHOUT CSP FEATURE.



TECHNICAL SPECIFICATION OF SINGLE PHASE, 25 KVA, 11/√3/0.25kV OUTDOOR TYPE DISTRIBUTION TRANSFORMER (EEL-1) WITHOUT CSP FEATURE.

MFD. BY:-

3	PHASE	AL	WOUND TRANSFORMER
TYPE		OUTDOOR	
STANDARD	IS:1180 PART-1	ENERGY EFFICIENCY LEVEL	2
KVA	100	MAX. TOTAL LOSSES AT 50% RATED LOAD	475
VOLTS-AT NO LOAD	HV	11000	MAX. TOTAL LOSSES AT 100% RATED LOAD
	LV	433	TYPE OF COOLING
BIL	HV	75	TEMP RISE { OIL °C 35 WDG °C 40
	LV	—	
AMPERS	HV	5.25	MASS OF OIL Kg 179
	LV	133.34	TOTAL MASS Kg 696
FREQUENCY Hz	50	VOL OF OIL L	219
VECTOR GROUP	Dyn-11	MONTH & YEAR OF MFG	12/2017
IMPEDANCE VOLT %		SERIAL NO.	DI -
CUSTOMER	MAHARASHTRA STATE ELECTRICITY DISTRIBUTION CO. LTD.		
ORDER NUMBER	LOA NO.		

MADE IN INDIA

CONNECTIONS & VECTOR DIAGRAM :



QRcode for details.

TECHNICAL SPECIFICATION OF SINGLE PHASE, 25 KVA , $11/\sqrt{3}/0.25$ kv OUTDOOR TYPE DISTRIBUTION TRANSFORMER (EEL-1) WITHOUT CSP FEATURE.

25KVA11/R3/250V1PHDTEEL-1 WO CSP

GTP Order Sequence	GTP Parameters	Date Type
1	Name of Manufacturer	TEXT
2	Reference Standard	TEXT
3	Energy efficiency level as per IS 1180 Part-I(2014)	TEXT
4	Whether transformer is Oil Natural Air Natural cooled type (Yes/No)	BOOLEAN
5	Whether transformer is suitable for Indoor /Outdoor installation	TEXT
6	Rating of Transformers in KVA	NUMERIC
7	Primary Voltage in KV	NUMERIC
8	Secondary Voltage in KV	NUMERIC
9	Whether neutral is solidly earthed (Yes/No)	BOOLEAN
10	Colour of transformer	TEXT
11	Approximate overall breadth of transformer in mm	NUMERIC
12	Approximate overall height of transformer in mm	NUMERIC
13	Approximate Diameter of transformer tank in mm	NUMERIC
14	Approximate height of transformer tank in mm	NUMERIC
15	Thickness of the side of transformer Tank plate in mm	NUMERIC
16	Thickness of the bottom of transformer tank plate in mm	NUMERIC
17	Thickness of the top of transformer tank plate in mm	NUMERIC
18	Total Radiating surface of transformer tank in sq. mtrs	NUMERIC
19	Size of base channel provided to tank and no.s	NUMERIC
20	Weight of Tank & fittings in kgs	NUMERIC
21	Weight of Core in kgs	NUMERIC
22	Weight of winding in kgs	NUMERIC
23	Weight of Oil in kgs	NUMERIC
24	Volume of Oil in Ltrs	NUMERIC
25	Total Weight of Transformer in kgs	NUMERIC
26	Core material used & its grade	TEXT
27	Type of core	TEXT
28	No. of steps of core for CRGO core	NUMERIC
29	Diameter of core in mm	NUMERIC
30	Effective core area.(sq.cm)	NUMERIC
31	Core Window Height in mm	NUMERIC

32	Centre to Centre Distance in mm	NUMERIC
33	Flux density in Tesla	NUMERIC
34	Thickness of core lamination in mm	NUMERIC
35	The temperature shall in no case reach a value that will damage the core itself, other parts or adjacent materials ,Max. temperature.	NUMERIC
36	Material of H.V winding	TEXT
37	Material of L. V. Winding	TEXT
38	Insulation provided to H.V winding	TEXT
39	Insulation provided to L.V. winding.	TEXT
40	Current density of H.V. winding (in Ampere/ sq.mm)	NUMERIC
41	Current density of L.V. winding (in Ampere/ sq.mm)	NUMERIC
42	No. of LV Winding Turns	NUMERIC
43	No. of HV Winding Turns	NUMERIC
44	Resistance of LV winding per phase at 20 oC in Ohms	NUMERIC
45	Resistance of HV winding per phase at 20 oC in Ohms	NUMERIC
46	Clearance between Core & L.V. winding in mm	NUMERIC
47	Clearances between L.V. & H.V. winding in mm	NUMERIC
48	Clearances between end insulation to Earth in mm	NUMERIC
49	Clearances between winding to tank in mm (min 30 mm).	NUMERIC
50	Insulation materials provided for core	NUMERIC
51	Length of coil used for HV winding in meter.	NUMERIC
52	Diameter of conductor used for HV winding (in mm)	NUMERIC
53	Cross section area of the coil used for HV winding (sq.mm)	NUMERIC
54	Length of coil used for LV winding in meter.	NUMERIC
55	Size of strip used for LV winding in mm	NUMERIC
56	No. of conductors in parallel for LV winding	NUMERIC
57	Total cross section area of LV conductor in sq. mm	NUMERIC
58	No. of H.V coils	NUMERIC
59	Thickness of locking spacers between H.V. coils (in mm)	NUMERIC
60	Quantity of total oil absorption (in liters) in first filling	NUMERIC
61	Total oil volume including Total Oil absorption in Ltrs	NUMERIC
62	Grade of Oil used	TEXT
63	Name of Oil manufactures to be supplied.	TEXT
64	Breakdown Values of Oil at the time of first filling (kV/mm) considering 2.5 mm gap	NUMERIC
65	Drain Valve (20 mm) provided to the transformer tank	TEXT
66	Earthing terminals with lugs is provided	TEXT

67	Lifting lugs provided	TEXT
68	Thermometer pocket is provided	TEXT
69	Rating of H.V. Bushings (in kV, A)	NUMERIC
70	Rating of L.V. Bushing (in kV, A)	NUMERIC
71	Material of HV Bushings and makes thereof	TEXT
72	Material of LV Bushings and makes thereof	TEXT
73	Reference standard of Bushings	TEXT
74	Minimum Creepage Distance of HV Bushing in mm (min.25 mm per kV)	NUMERIC
75	Minimum Creepage Distance of LV Bushing in mm (min.25 mm per kV)	NUMERIC
76	Minimum external clearances of bushing terminals: HV Phase to Earth	NUMERIC
77	Minimum external clearances of bushing terminals: LV Phase to Earth	NUMERIC
78	Maximum temperature rise of Oil in °C over an Ambient temp. Of 50°C by thermometer.	NUMERIC
79	Maximum temperature rise of winding in °C over an Ambient temp. Of 50°C by thermometer.	NUMERIC
80	Magnetizing current (No load) in Amps and its 3% of full load current at rated voltage referred to LV Voltage	NUMERIC
81	Magnetizing current (No load) in Amps and its 6 % of full load current at maximum voltage (112.5% of rated voltage)referred to LV side	NUMERIC
82	Max. Core Loss at rated voltage and rated frequency (Watts)	NUMERIC
83	Max. Total Losses (No load+Load losses at 75 °C) at50% Loading (Watts)	NUMERIC
84	Max. Total Losses (No load+Load losses at 75 °C) at100% Loading (Watts)	NUMERIC
85	Efficiency at 75 °C at unity P.F. at 100% load	BOOLEAN
86	Efficiency at 75 °C at unity P.F. at 75 % load	BOOLEAN
87	Efficiency at 75 °C at 0.8 P.F. lag at 125% load	BOOLEAN
88	Efficiency at 75 °C at 0.8 P.F. lag at 100 % load	BOOLEAN
89	Efficiency at 75 °C at 0.8 P.F. leading at 125% load	NUMERIC
90	Efficiency at 75 °C at 0.8 P.F. leading at 100% load	NUMERIC
91	% Impedance value at 75°C	NUMERIC
92	Make HV fuse	TEXT
93	Separate source power frequency withstand test for HV for 1 minute in kv(min)	NUMERIC
94	Separate source power frequency withstand test for LV for 1 minute in kv(min)	NUMERIC
95	Induced over voltage withstand test for 1 min. specify voltage frequency, time for test.	TEXT
96	Impulse test value (in kVP) .	TEXT
97	All type test report type test carried out on transformer at NABL laboratory shall be submitted along with the offer as per cl. XXII (c) of section (I) i.e. instructions to tenders .	TEXT
98	Unbalanced current test, air pressure test and temperature rise test shall be conducted as per format enclosed with the technical specification along the offer .	TEXT

99	All drawings shall be furnished with each offered item separately along with the offer.	TEXT
100	Oil absorption Calculation sheet shall be furnished with for each offered item separately along with the offer.	TEXT
101	Heat Dissipation Calculation sheet shall be furnished with for each offered item separately along with the offer.	TEXT
102	Flux Density calculation sheet with no. of Primary & Secondary turns shall be furnished with for each offered item separately along with the offer.	TEXT
103	Calculation sheet for 112.5% of rated v/f ratio (Over fluxing calculation sheet) offered shall be furnished with for each item separately along with the offer.	TEXT
104	Required documents , plant and machinery , list of order executed /under execution shall be furnished for each offered items separately along with this offer.	TEXT
105	The Information required under Quality Assurance shall be submitted with the offer in physical format & soft copy.	TEXT
106	The cost data in the prescribed format shall be submitted with the offer in physical format & soft copy .	TEXT
107	Firm shall confirm that the distribution transformer complies to the specified requirement of Indian Standard and submit copy of valid ISI licence along with the offer.	TEXT
108	The performance guarantee of transformer in Year	NUMERIC

Required Documents (To be uploaded online)

Sr. No.	NAME	SECTION	ITEM	DESCRIPTION
1	Type test reports	Technical Section	25KVA11/R3/25 0V1PHDTEEL-1	Valid Type test certificates from NABL accredited lab such as CPRI / ERDA as per clause II (3) of Section III.
2	BIS license	Technical Section	25KVA11/R3/25 0V1PHDTEEL-1	Valid BIS License or necessary documentary proof of having applied for renewal of validity of the BIS license.
3	BEE certificate	Technical Section	25KVA11/R3/25 0V1PHDTEEL-1	Upload Valid BEE certificate or necessary documentary proof of having applied for renewal of validity of the BEE certificate as per clause no XIV.
4	Turnover certificate	Commercial Section		Copy of latest turnover certificate for last 3 years duly certified by Chartered accountant as per clause II (4) of Section-III. (as per format 4)
5	List of orders	Commercial Section		List of orders executed/under execution certified by Chartered Engineer/accountant.
6	Balance sheet and profit & loss accounts	Commercial Section		Copy of balance sheet and profit & loss accounts of last 3 years certified by Chartered accountant.
7	Power of attorney if any.	Commercial Section		Notarized power of attorney in favor of appointed agent/representative.
8	EMD receipt (Bank guarantee or demand draft)	Commercial Section		Upload Copy of EMD receipt (Bank guarantee or demand draft).
9	Manufacturing capacity.	Commercial Section		Documentary evidence (e.g. Udyam Registration/NSIC/Chartered Accountant/Engineer Certificate) for manufacturing capacity to cover the quantity offered by the bidder and considering orders in hand.
10	Udyam registration certificate	Commercial Section		Documentary evidence in respect of classification of your unit as per Micro, Small and Medium Enterprises Development Act 2006.
11	Controlling stake certificate	Commercial Section		Certificate duly certified by C.E./C.A. that the person/entity does not have controlling stake in more than one entity applied for the Tender/Bid.(as per format 3)
12	Debar undertaking.	Commercial Section		Annexure-I regarding declaration along with the bid that bidder is not blacklisted/ debarred by any organization for last 3 years.
13	Undue influence certificate	Commercial Section		The bidder shall submit the undertaking certifying that you have not approached any one for undue influence (As per format-2).
14	GST registration	Commercial Section		Documentary evidence in respect of registered under the GST Law.
15	Declaration for New Supplier	Commercial Section		Annexure-O regarding declaration of participation as New Supplier in the tender
16	Certificate for no deviation.	Commercial Section		Certificate for no deviation (As per attached Format-5).
17	Manufacturing and testing facilities	Commercial Section		List of in house manufacturing and testing facilities as well as quality control set up.
18	List of orders in hand	Commercial Section		List of orders in hand certified by CA.

Sr. No.	NAME	SECTION	ITEM	DESCRIPTION
19	Declaration of legal litigations	Commercial Section		Annexure-F regarding declaration of legal litigations.
20	Experience	Commercial Section		Copies of orders executed by the bidder & the Certificate from the purchaser with regards to successful execution of the order for preceding three financial years as per clause II (2) of Section-III.
21	ISO certification	Commercial Section		ISO certification for quantity management system & environmental management system.
22	BIS License	Commercial Section		Upload Valid BIS License or necessary doc. proof of having applied for renewal of validity of the BIS license as per clause no XIV.
23	BEE Certificate	Commercial Section		Upload Valid BEE certificate or necessary documentary proof of having applied for renewal of validity of the BEE certificate as per clause no XIV.